

Determination of the head losses in metal body disc filters used in drip irrigation systems

Vedat DEMİR , Hüseyin YÜRDEM, Arzu YAZGI, Adnan DEĞİRMENCİOĞLU

Department of Agricultural Machinery, Faculty of Agriculture, Ege University, 35100, Bornova, İzmir - TURKEY

Received: 03.11.2008

Abstract: The objective of this study was to determine the head losses in several type metal body disc filters manufactured by domestic companies. In order to meet the objective, three different filter designs (L, LT and Y type), each at four different inlet and outlet pipe diameters, were used to measure the head losses at different flow rates in the laboratory. A total of sixteen filters manufactured by three domestic companies (A, B and C) and two different disc elements (linear and curly) were taken into consideration in this study.

A comparison of the different filter designs in terms of measured the head losses indicated that in all cases while the L type filters gave the highest head loss, the other two designs provided less head losses at the same flow rate. Furthermore, the head losses in C-LT type filters with curly groove shape discs were less than B-LT type filters with linear groove shape discs in comparing with the LT type filters produced by two different manufacturers even though the design and the size of the filter body were similar. The differences in the head loss can be clarified with the help of the results obtained from the structural characteristic of filtering elements.

As a result, in drip irrigation systems, the use of Y and LT type disc filters with curly groove shaped discs are recommended in order to obtain less head losses and low energy requirements when compared with filters used in this study.

Key words: Drip irrigation, disc filter, filtration, head loss

Damla sulama sistemlerinde kullanılan metal gövdeli disk filtrelerde yük kayıplarının belirlenmesi

Özet: Bu çalışmada, yerli yapım olarak imal edilen çeşitli tipte metal gövdeli disk filtrelerde meydana gelen yük kayıplarının belirlenmesi amaçlanmıştır. Bu amaçla, üç farklı dizayna (L, LT ve Y tip) ve her biri dört farklı giriş-çıkış kesitine sahip filtrelerin, laboratuvar koşullarında farklı debi değerlerindeki yük kayıpları ölçülmüştür. Ayrıca bu çalışmada iki farklı disk elemanı (doğrusal ve kıvrımlı yivli) da dikkate alınarak üç ayrı yerli firma (A, B ve C) tarafından imal edilen toplam on altı adet filtre denemeye alınmıştır.

Farklı dizayna sahip filtreler tüm giriş-çıkış kesiti koşullarında yük kayıpları açısından karşılaştırıldıklarında, aynı debi değerinde L tipi filtreler, diğer iki tip filtreye göre daha yüksek yük kayıpları göstermiştir. Bunun yanında dizayn ve ölçüleri benzer olarak iki farklı firma tarafından imal edilen, fakat farklı disk elemanı kullanılan LT tipi filtreler

* E-mail: vedat.demir@ege.edu.tr

karşılaştırıldıklarında, kıvrımlı yivli disk kullanılan C-LT tip filtrelerde, doğrusal yivli disk kullanılan B-LT tipi filtrelere göre daha düşük yük kayıp değerleri ölçülmüştür. Yük kayıplarındaki bu farklılık, filtre elemanlarının yapısal özellikleri ile açıklanabilir.

Sonuç olarak damla sulama sistemlerinde, çalışmada ele alınan filtreler karşılaştırıldıklarında, daha az yük kayıpları ve daha düşük enerji gereksinimi nedeniyle, Y ve LT tip filtrelerin kıvrımlı yivli disk elemanları ile kullanılması tercih edilmelidir.

Anahtar sözcükler: Damla sulama, disk filtre, filtrasyon, yük kaybı

Introduction

Although the energy consumption of drip irrigation systems is low, their initial investment is high since they operate at low pressures. For this reason, the operating life of these systems must be longer. The operating life of the systems is directly affected by clogging of the emitters installed in the laterals. Emitters have very narrow water passages, for they reduce water energy and pressure. However, this increases the risk of clogging. Keller and Bliesner (1990) stated that the clogging of drip emitters is the largest maintenance problem with drip systems while Capra and Scicolone (2004) implied that it was difficult to detect and expensive to clean, or replace, clogged emitters. The complete clogging of emitters can stop the system functioning and the clogging of some emitters in laterals results in non-uniform water distribution. Non-uniform water distribution can cause problems such as reduced yield and variable product quality.

The main causes for clogging are organic and inorganic materials, microbiological residues and chemical precipitates. Problems encountered due to clogging may be reduced by filtration and chemical processing (Adin and Alon, 1986; Gilbert and Ford, 1986; Ravina et al., 1990; Bulancak, 2000). Filtration is defined as the separation of solid materials by using their physical properties and proper filtration that extracts clean water. Filtration is essential to the efficient operation of drip irrigation systems and also it extends their operating life.

Several filters have been developed in order to facilitate drip irrigation. Some of these include sand separators, media filters, screen and disc type filters (Douglas and Bruce, 1985; Keller and Bliesner, 1990; Demir and Uz, 1994).

The performance of a filter can be defined by the head loss, the head loss ratio, the cleaning period, the

time required for cleaning the filter and the type of mechanical and hydraulic problems encountered (Ravina et al., 1990).

The local head loss in irrigation systems was found with the following equation as stated by many scientists (Daugherty and Franzini, 1965; Çengel and Cimbala, 2008).

$$\Delta H_f = k \frac{V^2}{2g} \quad (1)$$

where, ΔH_f is the local head loss (m), k is the local loss coefficient, V is the flow velocity ($m s^{-1}$) and g is the acceleration of gravity ($m s^{-2}$).

The local head loss is directly proportional to the square of flow velocity and as a result, the selection of appropriate flow velocity in a system becomes important. The optimal flow velocity in pumped lines that can range between 1 and 3 $m s^{-1}$ is usually considered from the point of construction and energy costs. On the other hand, when checking designs for permissible velocities, some engineers use 1.5 $m s^{-1}$ as a maximum, whereas others use 2.4 $m s^{-1}$ (Walski et al., 2003). Addink et al. (1983) stated that under normal conditions flow velocities should not exceed 3 $m s^{-1}$. However, when the plastic pipes are used as supply lines, velocities should not exceed 2.25 $m s^{-1}$. Howell et al. (1983) indicated that drip irrigation pipes are usually made of plastic and many pipe manufacturers recommended a flow velocity of 1.5 $m s^{-1}$.

Zeier and Hills (1987) focused on sand particle size and concentration effects on screen filter performance. They found that smaller ratios of filter pore size to sand particle size caused greater weights of sand to accumulate in the filter prior to reaching a predetermined head loss limit of 44.1 kPa.

Uz et al. (1994) worked on the head losses in L type small metal body screen and disc filter (150 μm), sand separator with 60.3 mm (2 inch) inlet and outlet diameter filters. They used clean water and soil-sand mixture at two different concentrations and they obtained the lowest head loss when screen filter was used. In their study, they used clean water whose flow rate ranged from 1.5 to 18 $\text{m}^3 \text{h}^{-1}$. The head losses were in the range of 0.3 – 5.6 kPa for screen filter, 0.3 – 30.3 kPa and 0.7 – 38.5 kPa for the disc and hydro-cyclone filter. They found that the head losses in disc filters depending upon the flow velocity was 14 kPa and 21 kPa for 1.5 m s^{-1} and 2.0 m s^{-1} , respectively.

Yürdem and Demir (2003) focused on some domestic type screen filters with an inlet and outlet pipe diameter of 73.0 mm (2½ inch) and 88.9 mm (3 inch). They found that using inappropriate filter body diameters caused an increase in the head losses. They found that by changing the inlet and outlet area of Y type filters, the head losses for 73.0 mm filter was reduced around 60% while some modifications on 88.9 mm filter resulted in 40% reduction in the head losses. They also studied the effects of changes in the diameter of filter body on the head losses, and for this purpose they tested filters at 152.4 and 203.2 mm (6 and 8 inch) body diameter. Both filters had an inlet diameter of 88.9 mm (3 inch). As a result of the study, they found that the head losses reduced around 67 – 75% depending upon the flow rate when the filter body diameter increased.

Any element in a pressurized irrigation system causes a head loss depending upon the property, but significant losses occur in filters. The level of the head loss depends upon the properties of the filter and the elements governing the movement of water during filtration. Among filter related variables, the filtering area in a filter is of importance and it is influenced by flow rate and impurities in water (Gilbert and Ford, 1986).

Bulancak et al. (2006) conducted a study to determine the efficiency of nine different filters (discs, screens, hydro-cyclone, sand separator and media filter). They tested L type disc filters at 60.3 mm (2 inch) inlet and outlet diameter. One of two filters tested had a metal body while the other was made of plastic, however both had a filtration level of 130 μm . The filters with different filtering features and filter

combinations used in drip irrigation systems were tested and the experiments were carried out in two steps. The first step included the tests in the laboratory in order to obtain their discharge–head loss relationship while the second one was conducted in an open channel to determine the head loss–time relationships and the filtering efficiency. All filters were tested alone and in combination. From the study, it was found that when clean water was used, the head losses for the L type disc filter with metal body was in the range of 6 – 48 kPa for the flow rate range of 12 – 26 $\text{m}^3 \text{h}^{-1}$. The head losses in disc filters depending upon the flow velocity was 6 kPa and 10 kPa for 1.5 and 2.0 m s^{-1} , respectively. Filtering efficiency for disc and screen filters was found within the ranges of 54 – 60% and 61 – 64%, respectively. On the other hand, the efficiency of the hydro-cyclone and sand separator was found as 37% and 36%, respectively. The highest efficiency was 81% when media filter was used.

Some studies included prediction equations for calculating the head losses in disc, screen and sand filters by using dimensional analysis and prediction equations compared with the experimental data (Puig-Bargués et al., 2005a; Yurdem et al., 2008).

In addition to the above mentioned studies, some studies concerned with the effects of clogging (Capra and Scicolone, 1998; Duran-Ros et al., 2009), and the filter performance and system status in wastewater use were studied by Ravina et al. (1992 and 1997), Capra and Scicolone (2004), Adin and Sacks (1991), Puig-Bargués et al. (2005b).

As stated by Capra and Scicolone (2004), screen filters are the ones mainly used in drip irrigation systems since they are simple, economical and easy to manage. Disc filters are also simple, economical, but they have been introduced recently.

Drip irrigation system was put into practice in 1980 following the developments in plastic industry. Due to many advantages and water shortage, it is also becoming prevalent in Turkey. There are many studies concerning the efficiency of drip irrigation systems, suitability for many crops, determination of the irrigation programs and finding out the technical properties of the system components, the head losses in laterals and optimum lateral lengths in the world and Turkey. But the studies on filters are very limited.

If the efficiency and energy saving are considered, the head losses in the selection of filters are of importance from the point of system management. For this reason, the type of the filter is the main issue both for the manufacturers and engineers. The objective of this study was to investigate the head losses in disc filters with metal body and at different geometry under different operating conditions.

Materials and methods

In the experiments, sixteen disc type filters manufactured by three domestic companies (A, B and C) at different specifications and designs were used. The physical properties and general specifications of the disc type filters are given in Table 1 and Figure 1, respectively.

Disc filters mainly consist of four parts; a filter body, a lid, locking mechanism and a filter element. The body of the filters has two different diameters and the body of each filter had inlet and outlet pipes welded on the main body with the outside diameters of 60.3 mm (2 inch), 73.0 mm (2 ½ inch), 88.9 mm (3 inch) and 114.3 mm (4 inch). The three filter designs were designated L, LT and Y type.

The inlet and outlet pipes of both, the L and LT type filters are perpendicular to each other but the inlet pipe of the LT type filters merges with the filter body tangentially. The Y type filters are known as in-line type filters since the inlet and outlet pipes are on the same axis as shown in Figure 1. The Y and L type filters are the ones manufactured by only company A whereas LT type filters are produced by company B and C.

A muff was welded to the edges of inlet and outlet pipes in order for a quick coupling of the filter to the irrigation system. There were also two outlet holes on the inlet and outlet pipes for connecting a manometer. The water inlet section had a special form to centralize the filter element in the main body.

The cover of the filter was made of metal and a stopper was placed on top of it. To avoid any leakage, a sealing ring was used between the cover and the main body of the filter. The cleaning of the filter was carried out by hand with the help of pressurized water, which was achieved easily by unscrewing the nuts on the cover.

Filtering element consists of cylindrical shaped rings made of plastic discs that are stacked onto a telescopic core. The discs are grooved on both sides and these grooves intersect to form the filtration element when compressed on the core. Two different type discs have linear and curly groove shape. Linear groove discs were used in Y, L and LT type filters that are produced by company A and B while the curly groove discs were placed in LT type filters produced by company C. The effective filtration area both, the outside surface and the channels was formed by the intersected grooves. The water that flows through these tiny grooves (channels) was cleaned and released from the outlet pipe. Filtration level of each filtering element was 130 μm . A sealing ring was placed between the filter and the main body to avoid leakage.

The experiments were conducted using a setup shown in Figure 2. Clean water was used during the experiments and but as a precaution, a Y40 type filter with a filtration level of 130 μm had been installed at the inlet of water for pre-cleaning and this filter was cleaned prior to each experiment. Water to the test apparatus was supplied from a tank by an electrically-driven centrifugal pump. The head losses at different flow rates were measured by two pressure transducers (E913 type, Bourdon Haenni, France) with an accuracy of 0.2% when the flow had been stabilized. The transducers were placed at the inlet and outlet of the filter. The flow rate during the experiments was controlled by the valves and was measured by using an electromagnetic flow meter (EMD-C100F type, BASS-ELA, CZ) with an accuracy of 0.5% and whose reading is in range of 10...100% Q max.

Measurements were logged on a data acquisition system (ADAM 4520 and ADAM 4017+, Advantech Automation Corp., USA), and on GeniDAQ version 4.25 data-acquisition software when the fluctuations in flow rate ceased. During the experiment, water temperature was measured by using a digital thermometer and it varied between 18 °C and 22 °C.

Results

The results obtained from the experiments carried out at different ranges of flow rates (Q), the head losses (ΔH_f), and Reynolds numbers (R_c) are tabulated

Table 1. Physical properties of disc filters used in the study.

Dimensions	Company A Y Type				Company A L Type				Company B LT Type				Company C LT Type			
	A-Y20	A-Y25	A-Y30	A-Y40	A-L20	A-L25	A-L30	A-L40	B-LT20	B-LT25	B-LT30	B-LT40	C-LT20	C-LT25	C-LT30	C-LT40
Inlet and outlet pipe outside diameter, mm (inch)	60.3 (2)	73.0 (2 ½)	88.9 (3)	114.3 (4)	60.3 (2)	73.0 (2 ½)	88.9 (3)	114.3 (4)	60.3 (2)	73.0 (2 ½)	88.9 (3)	114.3 (4)	60.3 (2)	73.0 (2 ½)	88.9 (3)	114.3 (4)
Inlet and outlet pipe inside diameter (D_p), mm	52.5	62.7	77.9	102.3	52.5	62.7	77.9	102.3	52.5	62.7	77.9	102.3	52.5	62.7	77.9	102.3
Inside diameter of filter body (D_b), mm	155	155	155	210	155	155	155	210	210	210	210	210	210	210	210	210
Length of filter body (L_b), mm	325	325	445	595	325	325	445	595	244	344	400	495	350	400	400	500
Angle between the body of the filter and inlet axis	30°	30°	30°	30°	90°	90°	90°	90°	90°	90°	90°	90°	90°	90°	90°	90°
Inside diameter of filter disc (d_f), mm	105	105	105	105	105	105	105	105	127	127	127	127	127	127	127	127
Outside diameter of filter disc (d_o), mm	129	129	129	129	129	129	129	129	163	163	163	163	163	163	163	163
Effective length of disc group (L_r), mm	315	315	430	545	315	315	430	545	231	331	370	470	325	375	375	475
Inflow area where the inlet pipe intersects with the body of the filter, mm ²	4330	6180	9540	16430	2240	3950	5350	8960	4370	6610	8260	13010	4370	6610	8260	13010
Outflow area where the outlet pipe inter-sects with the body of the filter, mm ²	2500	3570	5510	9480	2160	3090	4770	8210	2160	3090	4750	8210	2160	3090	4750	8210

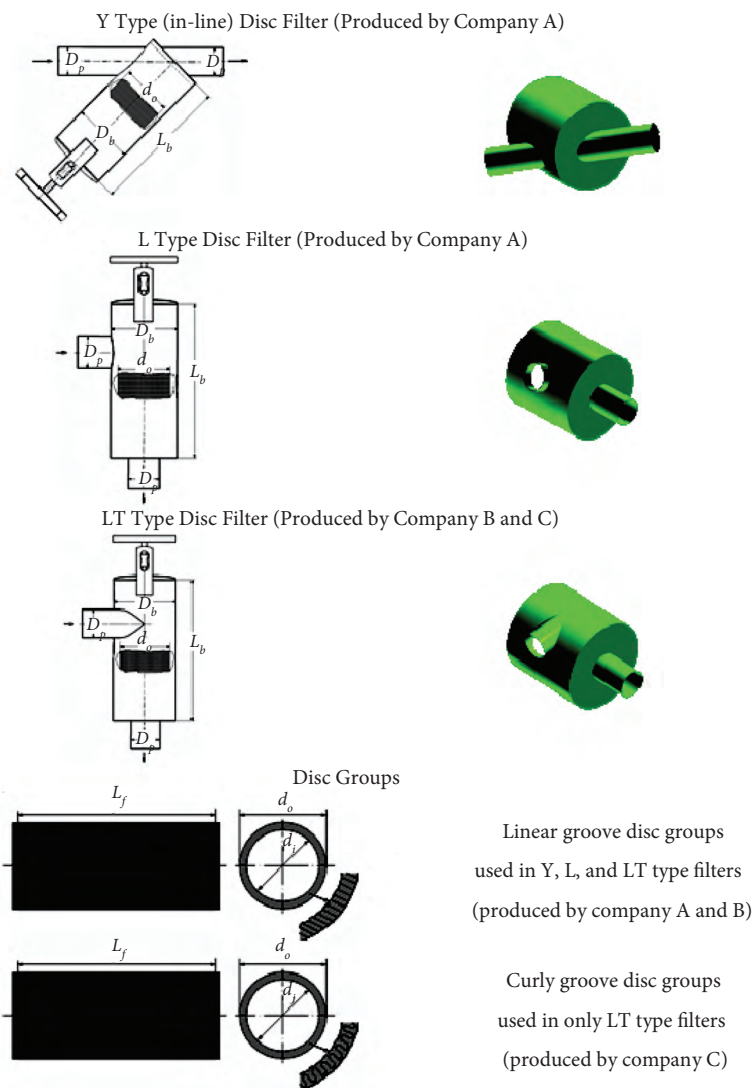

Figure 1. General specifications of the Y, L, LT type disc filters and disc groups.

in Table 2 for each filter used in the study. As an example, for L20 type filter, the flow rate changed in the range of 4.55 to 29.06 m³ h⁻¹ (0.58 to 3.73 m s⁻¹) and the head losses resulted within the range of 2.46 and 33.42 kPa while the Reynolds number varied between 30364 and 193940, which makes the flow turbulent. Mathematical models that define the relationship between flow rate and the head loss ($\Delta H_f = a Q^b$) were also developed for each filter. The model coefficients (a and b) and coefficients of determinations (R²) are given in Table 2. The

comparison of the filters at different inlet and outlet pipe diameters are also depicted in Figure 3, 4, 5 and 6.

As seen from the figures, the highest head loss values were measured in filters at the smallest inlet and outlet diameter at the same flow rate. On the other hand, the head losses decreased when the filter inlet and outlet diameter were larger. For instance, the head losses for A–Y filter at 20 m³ h⁻¹ flow rate were 9.5, 5.5, 3 and 1.3 kPa for A–Y20, A–Y25, A–Y30 and A–Y40, respectively. On the other hand, the head

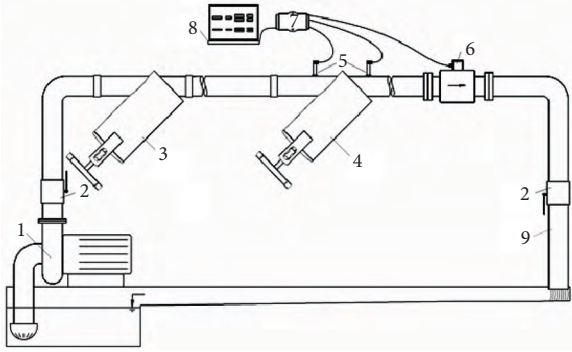

Figure 2. Schematic representation of the test apparatus: (1) electrically-driven centrifugal pump; (2) control valves; (3) disc filter for pre-filtering; (4) test filter; (5) transducers for head loss measurement; (6) electromagnetic flow meter; (7) data acquisition system; (8) computer; (9) outlet pipe.

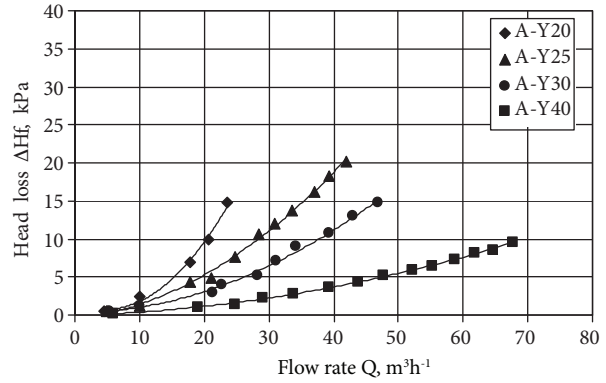

Figure 3. Head losses versus flow rates for Y type of disc filter with linear groove disc produced by company A.

Table 2. Flow characteristics and mathematical model coefficients and R²(%) between ΔH_f and Q of disc filters used in the study.

Company	Filter type	Filtering element type	Flow rate (Q), m ³ h ⁻¹	Flow velocity (V), m s ⁻¹	Reynolds number (R _e)	Head loss (ΔH _f), kPa	Model coefficients (ΔH _f = a Q ^b)		R ² %
			Min – Max	Min – Max	Min – Max	Min – Max	a	b	
A	A-Y20	Linear groove	4.50 – 23.57	0.58 – 3.03	30030 – 157279	0.49 – 14.74	0.0243 [0.1683]	1.9943 [0.0636]	99.69
	A-Y25		4.95 – 41.99	0.45 – 3.78	27655 – 234634	0.49 – 20.15	0.0233 [0.1645]	1.8079 [0.0517]	99.27
	A-Y30		5.25 – 46.88	0.31 – 2.73	23603 – 210778	0.49 – 14.74	0.0324 [0.2226]	1.5655 [0.0686]	98.48
	A-Y40		6.00 – 67.66	0.20 – 2.29	20557 – 231804	0.25 – 9.58	0.0120 [0.1783]	1.5621 [0.0485]	98.86
A	A-L20	Linear groove	4.55 – 29.06	0.58 – 3.73	30364 – 193940	2.46 – 33.42	0.2280 [0.3121]	1.4439 [0.1094]	97.21
	A-L25		4.98 – 41.30	0.45 – 3.72	27823 – 230760	0.74 – 28.99	0.0225 [0.4262]	1.9132 [0.1364]	96.09
	A-L30		5.00 – 50.22	0.29 – 2.93	22479 – 225772	0.74 – 29.74	0.0451 [0.1252]	1.6474 [0.0376]	99.59
	A-L40		5.55 – 67.28	0.19 – 2.28	19015 – 230494	0.49 – 20.55	0.0178 [0.2371]	1.6919 [0.0669]	98.16
B	B-LT20	Linear groove	10.40 – 34.20	1.34 – 4.39	69403 – 228230	3.55 – 23.35	0.0828 [0.0791]	1.6016 [0.0255]	99.80
	B-LT25		14.20 – 48.16	1.28 – 4.33	79334 – 269043	3.68 – 24.57	0.0578 [0.1362]	1.5436 [0.0391]	99.17
	B-LT30		23.57 – 52.21	1.37 – 3.04	105956 – 234722	4.91 – 15.97	0.0551 [0.1293]	1.4325 [0.0354]	99.57
	B-LT40		22.72 – 73.43	0.77 – 2.48	77839 – 251585	3.44 – 18.68	0.0378 [0.1135]	1.4198 [0.0293]	99.11
C	C-LT20	Curly groove	9.6 – 28.50	1.23 – 3.66	64055 – 190192	2.21 – 20.10	0.0227 [0.0387]	2.0246 [0.0131]	99.98
	C-LT25		10.40 – 54.04	0.94 – 4.86	58327 – 301692	0.30 – 18.72	0.0186 [0.3411]	2.3476 [0.1003]	98.38
	C-LT30		24.50 – 77.41	1.43 – 4.51	110056 – 347971	2.91 – 19.93	0.0095 [0.2222]	1.7457 [0.0579]	98.91
	C-LT40		22.92 – 87.43	0.77 – 2.96	78458 – 299442	1.31 – 4.94	0.0572 [0.1740]	0.9935 [0.0431]	98.88

Numbers given in brackets are the standard errors of the coefficients

losses for B-LT filter at 30 m³ h⁻¹ flow rate were found to be 19, 10.5, 7.5 and 5 kPa for the B-LT20, B-LT25, B-LT30 and B-LT40 type filter, respectively. The results obtained from this study are considered to be the natural cause of changes in inlet and outlet since the head losses given above go down when the inlet and outlet diameter increase and the flow velocity

goes down as it verifies the well known relation as given in equation (1).

Additional figures (Figures 7, 8, 9 and 10) were also drawn in order to make comparisons based on the head losses for all types of filters at the same inlet and outlet pipe diameters at different flow rates.

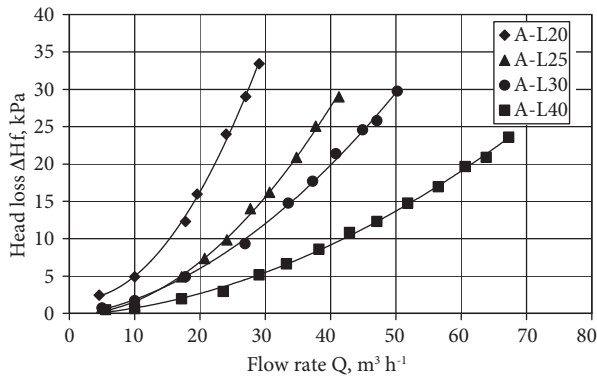

Figure 4. Head losses versus flow rates for L type of disc filter with linear groove disc produced by company A.

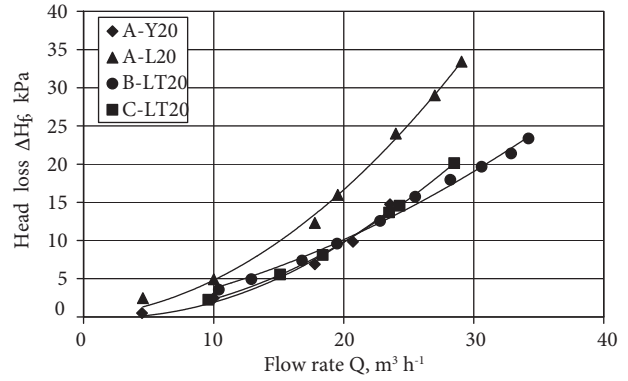

Figure 7. Comparison of head losses for all types of filters at 60.3 mm (2 inch) inlet and outlet diameter at different flow rates.

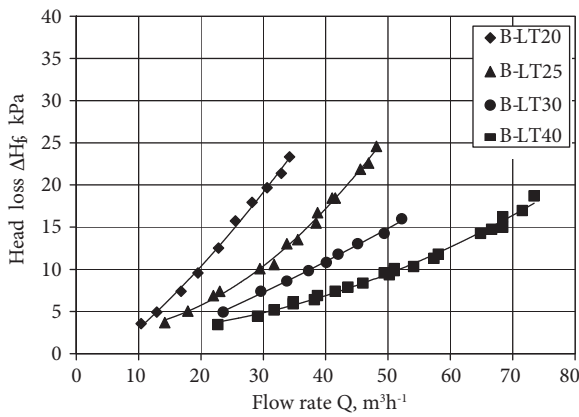

Figure 5. Head losses versus flow rates for LT type of disc filter with linear groove disc produced by company B.

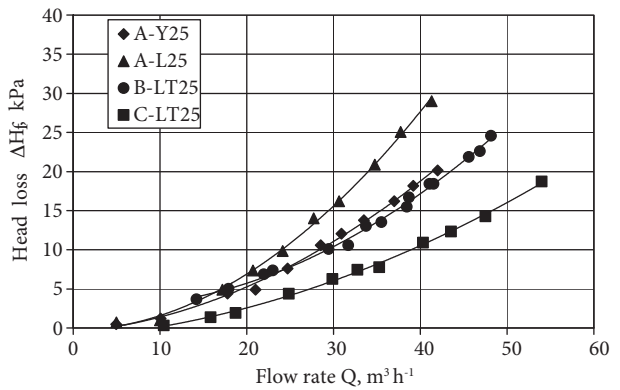

Figure 8. Comparison of head losses for all types of filters at 73.0 mm (2 ½ inch) inlet and outlet diameter at different flow rates.

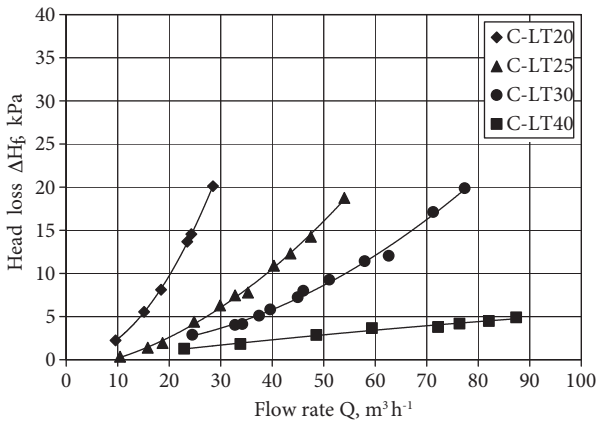

Figure 6. Head losses versus flow rates for LT type of disc filter with curly groove disc produced by company C.

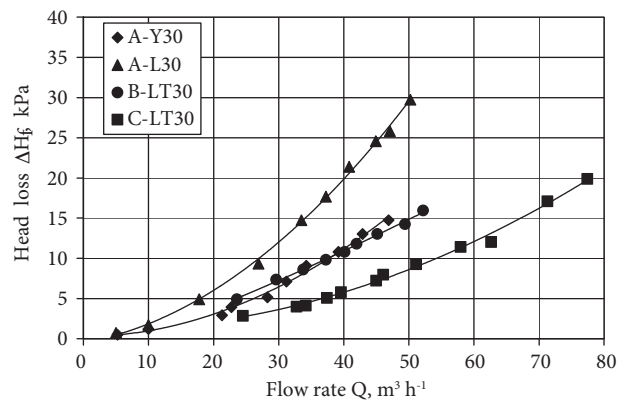

Figure 9. Comparison of head losses for all types of filters at 88.9 mm (3 inch) inlet and outlet diameter at different flow rates.

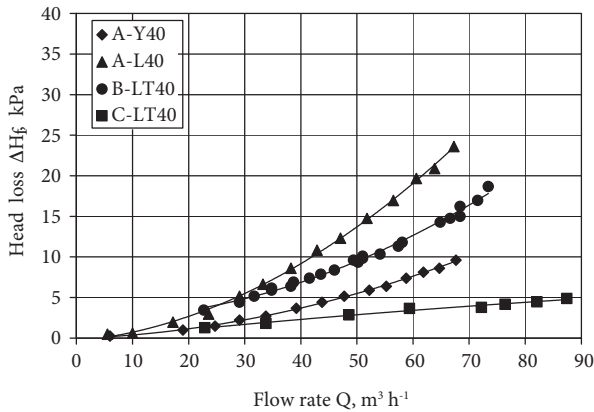

Figure 10. Comparison of head losses for all types of filters at 114.3 mm (4 inch) inlet and outlet diameter at different flow rates.

In all cases, the L type filters gave the highest head loss while the other two designs (Y and LT type) provided less head losses at the same flow rate. On the other hand, the head loss values were found very close for all other types of filters at 60.3 mm (2 inch) inlet and outlet diameter. The difference between the A–Y and B–LT type filters was very interesting since the head loss increased with the inlet pipe diameter and the difference became distinct at 114.3 mm diameter.

The head loss differences among three types of filters at a specific inlet and outlet diameter could be explained by the enlarged inlet area since the Y type filters have larger inlet and outlet area as compared to the other two filters.

Discussion

In order to compare the results, the water velocity was assumed to be in the range of 1.5 and 2.0 m s⁻¹, as the appropriate values for that is assumed to be 1 and 3 m s⁻¹ by Addink et al. (1983), Howell et al. (1983) and Walski et al. (2003). The results obtained for the different inlet and outlet diameter filters are depicted in Figure 11 and 12.

The head losses obtained for 60.3 mm (2 inch) inlet and outlet diameter metal body filter were compared with the findings obtained from the previous studies (Uz et al., 1994; Bulancak et al., 2006). It was found that the head losses for A–L20 filter at 1.5 m s⁻¹ (11.7 m³ h⁻¹) flow velocity was 6.5 kPa while it was 10.5 kPa at 2 m s⁻¹ (15.6 m³ h⁻¹) flow

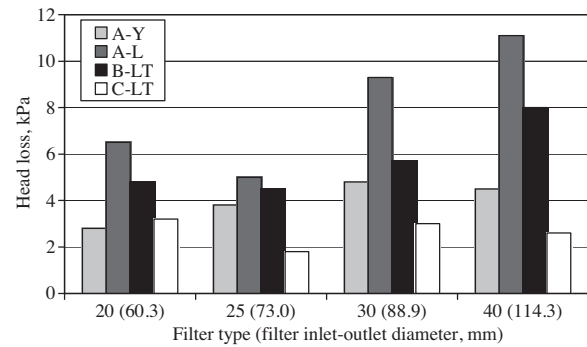

Figure 11. Head losses for all types of filters for different inlet and outlet diameters at a flow velocity of 1.5 m s⁻¹.

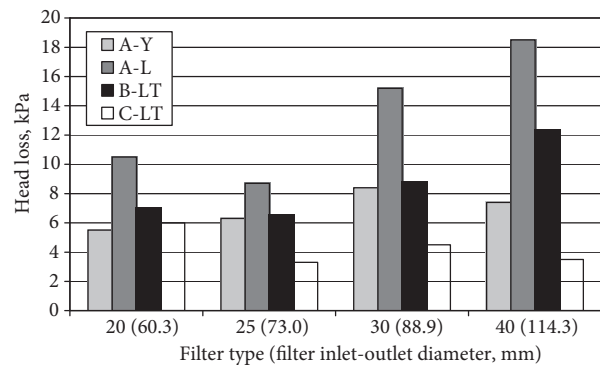

Figure 12. Head losses for all types of filters for different inlet and outlet diameters at a flow velocity of 2.0 m s⁻¹.

velocity. The results are in agreement as found by Bulancak et al. (2006) since they measured a head loss of 6 and 10 kPa at 1.5 and 2 m s⁻¹ flow velocity, respectively.

Uz et al. (1994) found that the head losses in smaller diameter filters to be 14 and 21 kPa when the flow velocity was 1.5 and 2.0 m s⁻¹, but the measured values in this study are lower than these. The difference could be attributed to the changes in the body diameter even though the geometry of the filters was similar. In their study, Yürdem and Demir (2003) found that an increase in the body diameter from 152.4 to 203.2 mm (6 to 8 inch) caused a reduction in the head losses around 67 – 75% depending upon the flow rate for the 88.9 mm (3 inch) filter.

Once the head losses obtained for the Y and L type filters manufactured by the same company are considered and compared, it can be seen from the figures (Figure 11 and 12) that the head losses in Y

type filters are lower than the L type filters. As an example, at 2 m s^{-1} ($15.6 \text{ m}^3 \text{ h}^{-1}$) flow velocity, the head losses at 60.3 mm (2 inch) inlet-outlet diameter filter were 5.5 kPa for the A-Y20 and 10.5 kPa for the A-L20 filter while the head losses for the 73 mm (2 ½ inch) inlet-outlet diameter disc filters at 2 m s^{-1} ($22.2 \text{ m}^3 \text{ h}^{-1}$) flow velocity were found to be 6.3 kPa for the A-Y25 and 8.7 kPa for the A-L25 type. This difference between the two filters became very distinct at 114.3 mm (4 inch) inlet-outlet diameter filters and at 2 m s^{-1} flow velocity ($59.1 \text{ m}^3 \text{ h}^{-1}$) as the measured head losses were 7.4 and 18.5 kPa for the A-Y40 and A-L40, respectively.

The difference between the Y and L type filters are due to the construction. When the constructional differences between the two were examined (Figure 1) it is seen that in Y type filters as also called in-line type filters, water enters and exits from the filter at a certain angle (see Table 1, inflow and out flow areas), which makes the cross-section area of water flow larger. In L type filters, water enters the filter body perpendicularly and the resistance to water is much more than the Y type. As a result, the head losses in L type filters increase. Yürdem and Demir (2003) found that even geometry such as circular or ellipse inlet and outlets affect the head losses and the use of the same filter but different geometry, the head loss at 73 mm (2 ½ inch) filter goes down about 60.3% while the reduction is about 40% at 88.9 mm (3 inch) filter.

Furthermore, the head loss values in the C-LT type filters were less than the B-LT type filters when the LT type filters produced by two different manufacturers were compared even though the design and the filter body were similar. For instance, the head loss at a flow velocity of 1.5 m s^{-1} for 88.9 mm (3 inch) inlet and outlet diameter filters was approximately 3 kPa in the C-LT type filter while 5.7 kPa were found in B-LT type filter (Figure 11). The same conditions are valid for the other filters, for example, the head loss at a flow velocity of 2 m s^{-1} for 114.3 mm (4 inch) inlet and outlet diameter filters was approximately 3.5 kPa in the C-LT type filter while

12.3 kPa, 7.4 kPa and 18.5 kPa were found in B-LT type, A-Y type and A-L type filters, respectively (Figure 12). The differences in the head loss were attributed to the structural characteristic of filtering element since the shape of discs used by the company C have curly groove water passage area which is larger than the other linear groove shaped discs. Therefore, water in the filter passes larger passage area as to linear groove discs and the head losses decrease considerably.

As a result, it could be stated that under the same design and operating conditions Y and LT type filters with curly groove filtering element provide the lowest head loss.

Conclusions

For operational, design and manufacturing purposes, the Y type (in-line) and LT type filters provide the lowest head loss under the same constructional and operating conditions. In addition to this, a considerable decrease in the head losses was found when the filtering elements with curly grooves were used. These findings are of importance from the point of energy save and they should be considered by the manufacturers and drip irrigation system designers in order to use the energy sources efficiently.

On the contrary, there has been a significant increase in the production of metal body since they are cheap. However, these structures are exposed to corrosion when certain chemicals are used for fertigation which prevent clogging in drip irrigation systems. The solution to this is to isolate all metal parts by using appropriate painting technology in drip irrigation systems.

On the other hand, the selection of the suitable filter is the most important issue while cleaning, maintenance and replacement of filters should be made regularly in order to avoid clogging and to extend the life of the drip irrigation system since the initial cost of installing a new system is very high.

References

- Adin, A. and G. Alon. 1986. Mechanisms and process parameters of filters screens. *Journal of Irrigation and Drainage Engineering* (ASCE). 112: 293-304.
- Adin, A. and M. Sacks. 1991. Dripper-clogging factors in wastewater irrigation. *Journal of Irrigation and Drainage Engineering* (ASCE). 117: 813-827.

- Addink J.W., J. Keller, C.H. Pair, R.E. Sneed and J.W. Wolfe. 1983. Design and operation of sprinkler systems. In: Design and Operation of Farm Irrigation Systems (Ed. M.E. Jensen), ASAE Monograph, No.3, Michigan, USA, pp. 621-660.
- Bulancak, S. 2000. Ege Bölgesi Pamuk Tarımında Damla Sulama Sistemlerinin Uygulanabilirliğinde Filtre Seçimi ve Performansı Üzerinde Bir Araştırma. Yüksek Lisans Tezi. Ege Üniversitesi, Fen Bilimleri Enstitüsü, p. 155.
- Bulancak, S., V. Demir, H. Yürdem and E. Uz. 2006. Damla sulama sistemlerinde kullanılan çeşitli filtre ve filtre kombinasyonlarının açık kanal sularında kullanılmasındaki etkinliklerinin belirlenmesi. Ege Üniversitesi, Ziraat Fakültesi Dergisi. 43: 85-96.
- Capra, A. and B. Scicolone. 1998. Water quality and uniformity in drip/trickle irrigation systems. J. Agric. Engng. Res. 70: 355-365.
- Capra, A. and B. Scicolone. 2004. Emitter and filter test for wastewater reuse by drip irrigation. Agric. Water Manage. 68: 135-149.
- Çengel Y.A. and J.M. Cimbala. 2008. Akışkanlar Mekaniği Temelleri ve Uygulamaları. 1.Baskıdan Çeviri, (Editör; T. Engin, Editör Yardımcıları; H.R. Öz, H. Küçük, Ş. Çeşmeci). İzmir Güven Kitabevi, İzmir.
- Daugherty, R.L. and J.B. Franzini. 1965. Fluid Mechanics with Engineering Applications. 6th Ed. McGraw-Hill, Inc.
- Demir, V. and E. Uz. 1994. Damla sulama sistemlerinde kullanılan filtreler. Ege Üniversitesi, Ziraat Fakültesi Dergisi. 31: 177-184.
- Douglas, A. and P.E. Bruce. 1985. Filtration analysis and application. In: Proceedings of the Third International Drip/Trickle Irrigation in Action, ASAE, St.Joseph, MI, pp. 58-68.
- Duran-Ros, M., J. Puig-Bargues, G. Arbat, J. Barragan and F. Ramirez de Cartagena. 2009. Effect of filter, emitter and location on clogging when using effluents. doi:10.1016/j.agwat.2008.06.005. Agric. Water Manage. 96: 67-79.
- Gilbert, R.G. and H.W. Ford. 1986. Operational principles-emitter clogging. In: Trickle Irrigation for Crop Production (Eds.: G.S. Nakayama and D.A. Bucks). Elsevier Science Publishers, Netherland, pp.142-237.
- Howell, T.A., D.S. Stevenson, F.K. Aljibury, H.M. Gitlin, I-Pai Wu, A.W. Warrick and P.A.C. Raats. 1983. Design and operation of trickle (drip) systems. In: Design and Operation of Farm Irrigation Systems (Ed. M.E. Jensen), ASAE Monograph, No.3, Michigan, USA, pp. 663-717.
- Keller, J. and R.D. Bliesner. 1990. Sprinkle and Trickle Irrigation. An Avi Book, Van Nostrand Reinhold, New York, NY.
- Puig-Bargués, J., J. Barragan and F. Ramirez de Cartagena. 2005a. Development of equations for calculating the head loss in effluent filtration in microirrigation systems using dimensional analysis. Biosystems Engineering. 92: 383-390.
- Puig-Bargués, J., G. Arbat, J. Barragan and F. Ramirez de Cartagena. 2005b. Hydraulic performance of drip irrigation subunits using WWTP effluents. Agric. Water Manage. 77: 249-262.
- Ravina, I., E. Paz, Z. Sofer, A. Marcu, A. Shisha and G. Sagi. 1992. Control of emitter clogging in drip irrigation with reclaimed wastewater. Irrig. Sci. 13: 129-139.
- Ravina, I., E. Paz, Z. Sofer, A. Marcu, A. Shisha, G. Sagi, Z. Yechialy and Y. Lev. 1997. Control of clogging in drip irrigation with stored treated municipal sewage effluent. Agric. Water Manage. 33: 127-137.
- Ravina, I. E. Paz, E. Soler, G. Sagi, Z. Yechialy, Z. Lavi and A. Marcu. 1990. Filtration requirements for emitter clogging control. In: Proceedings of the 5th International Conference on Irrigation, Agritech, Tel-Aviv, Israel, pp. 223-229.
- Uz, E., V. Demir and M. Eren. 1994. Damla sulama sistemlerinde kullanılan filtreler üzerine bir araştırma. 15. Ulusal Tarımsal Mekanizasyon Kongresi Bildiriler Kitabı, Antalya, pp 572-581.
- Walski, T.M., D.V. Chase, D.A. Savic, W.M. Grayman, S. Beckwith and E. Koelle. 2003. Advanced Water Distribution Modeling and Management. Haestad Press, Waterbury CT, USA.
- Yürdem, H. and V. Demir. 2003. Damla sulama sistemlerinde kullanılan elek filtrelerde görülen bazı tasarım hatalarının yük kayıpları üzerine etkisi. Ege Üniversitesi, Ziraat Fakültesi Dergisi. 40: 81-88.
- Yurdem, H., V. Demir and A. Degirmencioglu. 2008. Development of a mathematical model to predict head losses from disc filters in drip irrigation systems using dimensional analysis. Biosystems Engineering. 100: 14-23.
- Zeier, K.R. and D.Y. Hills. 1987. Trickle irrigation screen filter performance as affected by sand size and concentration. Transactions of the ASAE. 30: 735-739.