

Synthesis of benzaldehyde by Swern oxidation of benzyl alcohol in a continuous flow microreactor system

Lin ZHU^{1,2}, Xiaohui XU^{1,2}, Fuping ZHENG^{1,2,*}

¹Beijing Advanced Innovation Centre for Food Nutrition and Human Health, Beijing Technology and Business University, Beijing, P.R. China

²Beijing Laboratory for Food Quality and Safety, Beijing Technology and Business University, Beijing, P.R. China

Received: 22.04.2017

Accepted/Published Online: 29.08.2017

Final Version: 08.02.2018

Abstract: Preparation of benzaldehyde by Swern oxidation of benzyl alcohol was carried out in a continuous flow microreactor system. Dimethyl sulfoxide (Me₂SO) was used as oxidizing agent and oxalyl chloride or *p*-toluenesulfonyl (*p*-TsCl) chloride was used as the activating agent. Benzyl alcohol was oxidized to benzaldehyde by the Me₂SO-activating agent mixture in the continuous flow microreactor system. The optimized reaction conditions of the Swern oxidation were as follows: oxalyl chloride was used as the activating agent; the mole ratio of Me₂SO, oxalyl chloride, and benzyl alcohol was 4:2:1; the flow rate of Me₂SO was 1.5 mL/min; the reaction temperature was 15 °C; length of delay loop was 1.5 m; a Caterpillar Split-Recombine Micro Mixer was used; and all of the experiments were completed at atmospheric pressure. The yield of benzaldehyde can reach 84.7% with selectivity of 98.5%. Due to the small reactor volume and short residence times, the Swern oxidation of benzyl alcohol in a continuous flow microreactor system can be operated at nearly room temperature (5–19 °C) instead of –70 °C in a batch reaction, with residence time of reactants in microreactors in milliseconds instead of several hours in a batch reaction.

Key words: Swern oxidation, microreactor, benzaldehyde, benzyl alcohol

1. Introduction

Benzaldehyde, which occurs naturally in almond, makes a characteristic almond-like odor. It is commonly used as a flavor in foods and drinks, and as a fragrance in cosmetics and household chemicals. Moreover, benzaldehyde also acts as a crucial intermediate in chemical and pharmaceutical production,¹ and it is used to prepare herbicides and plant growth regulators when it comes to agriculture.² Various oxidants were applied to synthesize benzaldehyde in the past several years, like transition-metal derivatives (Collins, pyridinium chlorochromate, and pyridinium dichromate reagents),^{3–5} hypervalent iodine reagents (2-iodoxybenzoic acid and Dess–Martin periodinane),^{6,7} and hypervalent manganese reagents (KMnO₄). They performed well in efficiency, but usually the transition metallic and halide elements also caused severe environment contamination. Moreover, the high activity of these oxidants easily leads to overoxidizing, so a lot of byproducts are inevitable. In order to overcome these shortcomings, heterogeneous catalysts (NaOCl in PTC),⁸ mild oxidants (hydrogen peroxide, O₂), and the Me₂SO-activator system (Swern oxidation)^{9,10} have been widely used and developed recently. The Me₂SO-activator system, which is known as Moffatt–Swern oxidation, consists of dimethyl

*Correspondence: zhengfp@btbu.edu.cn

sulfoxide (Me_2SO) and an electrophilic species at extremely low temperatures. Because of its totally metal-free quality, it is thought to be environmentally benign.

The Swern experimental conditions are challenging because activation of Me_2SO is usually accompanied by Pummerer rearrangement.^{11,12} Therefore, the temperature of the reaction is severely restricted between $-60\text{ }^\circ\text{C}$ and $-10\text{ }^\circ\text{C}$ ¹³ as only in that case could the side reaction be reduced to an acceptable level. Control of the reaction conditions of Swern oxidation is thus of great importance.

In order to achieve that, the dropwise addition of the reagent should be done and the reaction system should be stirred for a very long time in a macroscale batch reactor.^{10,14} Moreover, for such kinds of extremely exothermic reactions or reactions that proceed through highly reactive and unstable intermediates, the use of batch reactors has more disadvantages that are related to temperature control and safety problems.

A continuous flow microreactor system, in which the reactor volume is so small that the characteristic dimensions are in millimeter or even micrometer range, has excellent mixing and heat transfer ability. Only small amounts of reactants are consumed at the same time so that less heat is given off and then potentially dangerous situations can be avoided.¹⁵ As a result, Swern oxidation, which must be conducted under extremely low temperatures, could be safely performed in the continuous microreactor system at nearly ambient temperature. In addition, the residence time of the reactant in the continuous microreactor system is much less than that in batch systems and leads to only a few intermediates accumulating, which is beneficial to improve the yield and selectivity of Swern reaction.^{11,16}

Therefore, we performed our research into conducting Swern oxidation with a microreactor to prepare benzaldehyde, employing a Me_2SO -activator system as the oxidant, benzyl alcohol as the substrate, and triethylamine as the base. The parameters of Swern oxidation were also investigated and screened in order to find the optimal reaction parameters, which include the type of micromixers, type of activators, temperature, flow rate residence time, and the mole ratio of Me_2SO , oxalyl chloride, and benzyl alcohol. This research has not been published before and, at the same time, the method is environmentally benign, safe, and efficient. Compared with the existing data in the literature, which reported the yield of benzaldehyde of 78% at $0\text{ }^\circ\text{C}$ and 75% at $20\text{ }^\circ\text{C}$, the optimized yield of 84.7% with a selectivity of 98.5% is relatively considerable.¹⁶

2. Results and discussion

2.1. Selection of activator

The result of Swern oxidation is greatly influenced by the type of activators. In 1978, Mancuso et al. found that the Me_2SO -oxalyl chloride system showed the best activity and led to much better yields when compared with Me_2SO -trifluoroacetic anhydride,¹⁷ pyridinium chlorochromate, and Me_2SO -pyridine- SO_3 . On this basis, oxalyl chloride is widely used as the activator in many recent studies of Swern oxidation.

However, oxalyl chloride will decompose in a humid environment, react violently with water, and emit gases CO , CO_2 , and HCl , known to be toxic and corrosive. Taking green chemistry and the safety of industrial production into account, *p*-toluenesulfonyl chloride (*p*- TsCl) is often used as the activator instead of oxalyl chloride.¹⁰ Compared with oxalyl chloride, *p*-toluenesulfonyl chloride tends to be less toxic and safe. At the same time, the activity of *p*-toluenesulfonyl chloride is decreased, too. Consequently, it is necessary to find a method with low toxicity and high effect. Both oxalyl chloride and *p*-toluenesulfonyl chloride were chosen as activators and parameters were screened in later experiments.

2.2. Mechanistic considerations and microreactor setup

In the Me_2SO -oxalyl chloride system, activator **2** interacts with Me_2SO **1** or **1'** to give the sulfonium ion, which contains a leaving group, chlorodimethylsulfonium salt **4**. The first intermediate **4** quickly reacts with benzyl alcohol **5** to form the key phenylmethoxydimethylsulfonium salt **6**. The additions of triethylamine deprotonate the phenylmethoxydimethylsulfonium ion to give intermediate **7**, which is alternatively converted to dimethyl sulfide (DMS) and benzaldehyde **8** (Scheme 1).

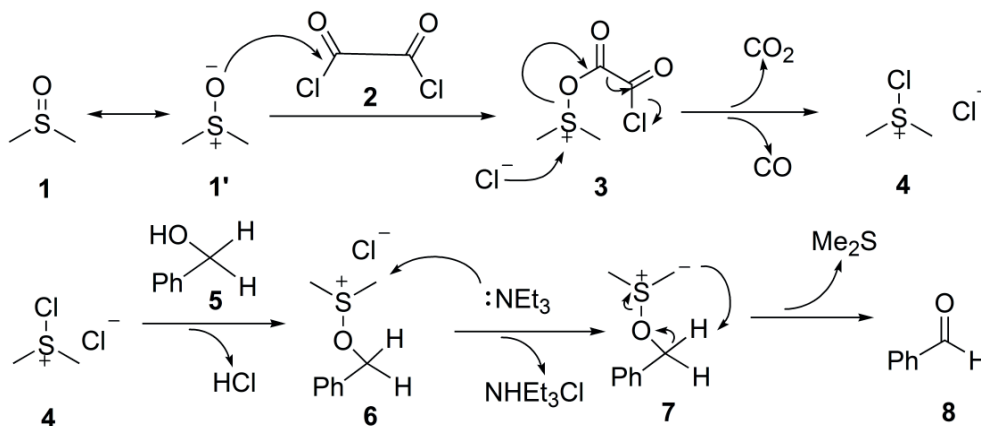

Scheme 1. The proposed mechanism of the Swern oxidation with oxalyl chloride.

The Me_2SO -*p*-TsCl system is similar to the Me_2SO -oxalyl chloride system. The Me_2SO is activated by *p*-TsCl to form key intermediates tosyloxydimethylsulfonium chloride **9** or chlorodimethylsulfonium tosylate **10**. Then the activated intermediates quickly react with benzyl alcohol **5** to give the phenylmethoxydimethylsulfonium salt **6** and an equivalent *p*-toluene sulfonic acid. Finally the triethylamine takes away an equivalent proton of intermediate **6** to give intermediate **7**, which is alternatively converted to dimethyl sulfide and benzaldehyde **8** (Scheme 2).

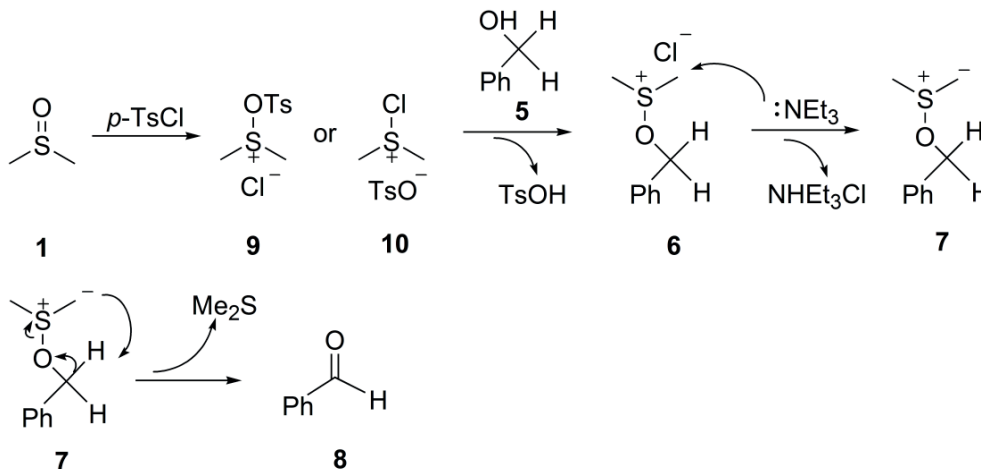

Scheme 2. The proposed mechanism of the Swern oxidation with *p*-TsCl.

Figure 1 shows a schematic drawing of the microreactor setup. Me_2SO , oxalyl chloride, and benzyl alcohol were pumped into the system through three HPLC pumps (P1, P2, and P3). Me_2SO and oxalyl chloride were premixed with a T-shaped joint (M1) and reacted in a reactor loop (R1) with release of CO and CO_2 to give

intermediate **4**, and then intermediate **4** was well blended with benzyl alcohol in the micromixer (M2) and reacted with it in a reactor loop (R2) to form another intermediate **6**. An appropriate length of reactor loop (R2) was of great use to control the reaction progress and product selectivity, avoiding too many byproducts. M1, M2, R1, R2, and most of the tubes were sunk in the constant-temperature bath. The effluent was collected in an Erlenmeyer flask containing continuously magnetic stirred triethylamine. A separating funnel that could clearly show the state of the effluent was between the effluent tube and Erlenmeyer flask.

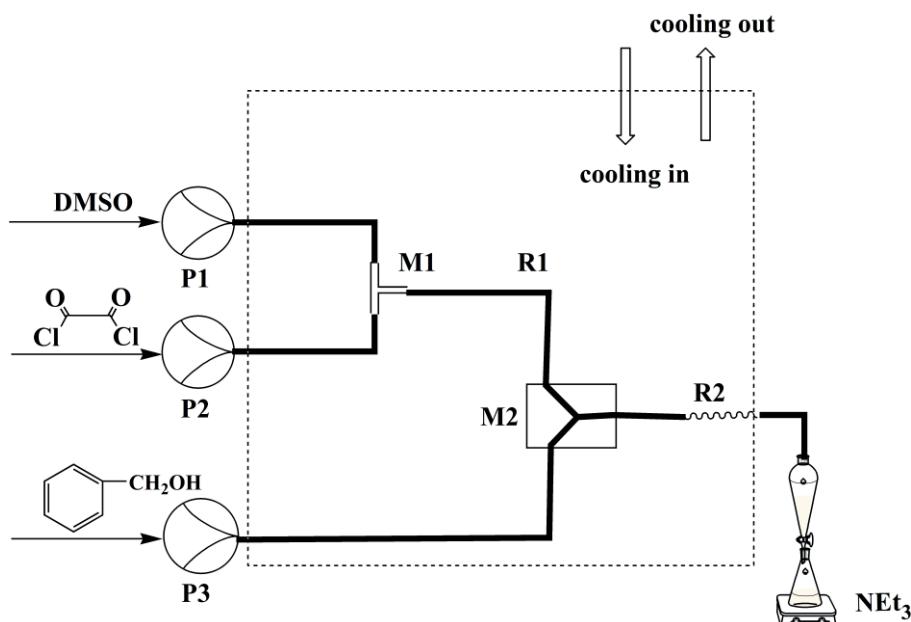

Figure 1. Schematic drawing of the continuous microreactor system.

2.3. Optimization of reaction parameters

The molar ratio of $n(\text{Me}_2\text{SO}) : n(\text{activator}) : n(\text{alcohol}) = 3:1.5:1$ was found to be the best according to the works conducted in batch systems,¹⁰ and it was chosen as the molar ratio of most experiments except the ones related to optimizing the molar ratio itself. Linden et al. investigated the conversion of the Swern reaction at $-20\text{ }^\circ\text{C}$ to $30\text{ }^\circ\text{C}$ in a continuous microreactor system¹¹ The results showed that the conversion was considerable from -20 to $20\text{ }^\circ\text{C}$ but sharply decreased at $20\text{--}30\text{ }^\circ\text{C}$. Considering the aim of creating a mild and effective experimental method, all experiments were performed between $0\text{ }^\circ\text{C}$ and $20\text{ }^\circ\text{C}$, at atmospheric pressure.

2.3.1. Optimization of the temperature and flow rate

The temperature and flow rate were investigated under the condition of $n(\text{Me}_2\text{SO}) : n(\text{oxalyl chloride}) : n(\text{benzyl alcohol}) = 3:1.5:1$ and $L(\text{R2}) = 1.5\text{ m}$. The reaction temperature ($5, 10, 13, 15, 17,$ and $19\text{ }^\circ\text{C}$) and the flow rate of Me_2SO ($1.2, 1.5, 1.8,$ and 2.0 mL/min) were studied separately.

2.3.1.1. Oxalyl chloride as the activator

The results are shown in Figures 2 and 3. The highest yield at which oxalyl chloride acted as the activator was 70.0%, and the best selectivity was 97.3% at $15\text{ }^\circ\text{C}$ and Me_2SO flow rate of 1.5 mL/min . In this case, 1.024 g

benzaldehyde was obtained in 1 h (1.024 g/h). Obviously, the optimal temperature is much higher than the one ($-60\text{ }^{\circ}\text{C}$) in the conditional batch reactor. That could be attributed to the excellent heat transfer ability (heat transfer coefficients reached $60,000\text{ W m}^{-2}\text{ K}^{-1}$, compared to $100\text{ sW m}^{-2}\text{ K}^{-1}$ in batch reactors).¹⁸ Consequently, reaction exotherms can be easily dissipated, enabling highly energetic materials to be synthesized in a safe manner.

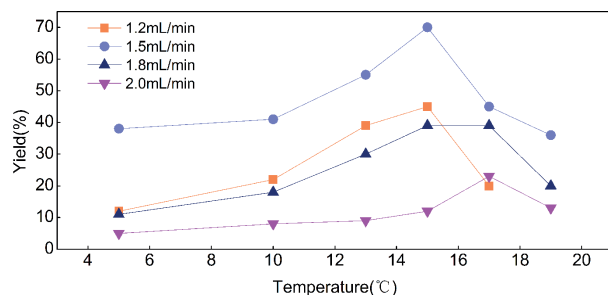

Figure 2. Influence of temperature on yield when oxalyl chloride acted as the activator.

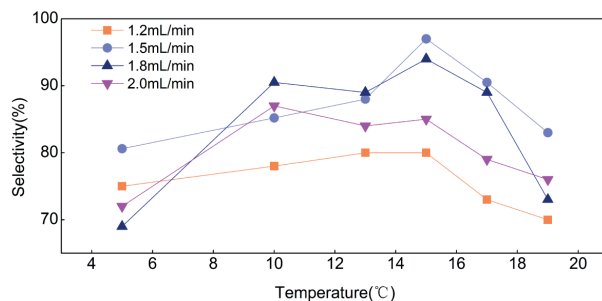

Figure 3. Influence of temperature on selectivity when oxalyl chloride acted as the activator.

The selectivity of benzaldehyde was very considerable (more than 85.0%), as shown in Figure 3. In other words, high-purity products can be obtained in most cases. The microreactor has a very small internal volume; for example, the internal volume of the Caterpillar Split-Recombine Micro Mixer (CPMM) is $30\text{ }\mu\text{L}$ and that of the Slit Interdigital Micro Mixer (SIMM) is $5.625\text{ }\mu\text{L}$. This means that only a small amount of reactants interacted with each other at a moment and accumulation of the labile intermediate was minimized. In addition, because of the short residence time, the side reactions of the labile intermediate were limited.

In the microreactor, temperature and flow rate are the key factors that can decide the conversion of the reactants, yield, and selectivity of products. The temperature and flow rate interacted with each other in the progress. When the flow rate became slower, the optimal temperature for yield was gradually decreased; on the other hand, when the flow rate became faster, the optimal temperature increased. This is easy to explain by basic physical knowledge. When the flow rate stays at a relatively low level, the reactants are well mixed because of the sufficient contact time in tubes at low temperatures. As the temperature increases, byproducts are accumulated, which leads to low yield. Otherwise, when the flow rate is at high levels, the residence time would be too short to mix the reactants well. At this point, increasing the temperature could make the molecules of reactants move faster, thus improving the rate of mass transfer and conversion of reaction. We can conclude that the velocity of reaction, which was intensively exothermic and accompanied by a number of side reactions, could be improved by increasing the temperature, but the yield was not always improved.

2.3.1.2. *p*-TsCl as the activator

Figures 4 and 5 show the results of applying different temperatures and flow rates when keeping $n(\text{Me}_2\text{SO}):n(\text{oxalyl chloride}):n(\text{benzyl alcohol})$ to 3:1.5:1 and $L(\text{R}2)$ to 1.5 m. The highest yield of benzaldehyde was only 15.0%, 302 mg/h, which was much lower than oxalyl chloride activating Swern reactions. At the same time, however, the selectivity was obviously considerable, which reached 95.0% at $17\text{ }^{\circ}\text{C}$ and 1.2 mL/min. This phenomenon also proved the ability of the microreactor in increasing selectivity and controlling the accumulation of byproducts.

When the flow rate of Me_2SO was less than 1.5 mL/min, we got little benzaldehyde in the system even if the residence time was increased. The yields were not significantly improved although the temperature rose.

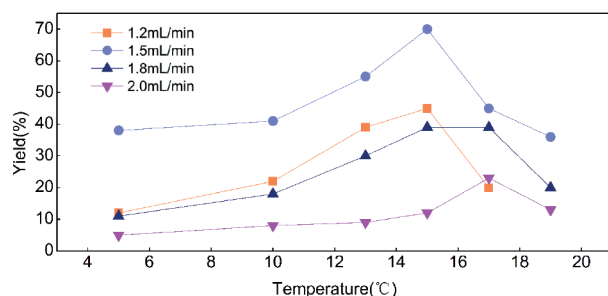

Figure 4. Influence of temperature on yield when *p*-TsCl acted as the activator.

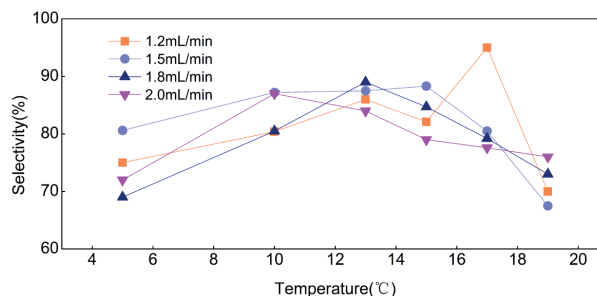

Figure 5. Influence of temperature on selectivity when *p*-TsCl acted as the activator.

However, the yields reached a peak for almost the whole temperature range at the flow rate of Me₂SO of 1.5 mL/min. When the flow rate continued to increase, regardless of whether the temperature was increased or not, the yield decreased. This could be explained by the flow rate directly influencing the residence time with too short of a residence time for sufficient mixing. Especially at higher temperatures than 15 °C a mass of byproducts accumulated, which caused a great decrease in the selectivity of benzaldehyde.

2.3.2. Optimization of the residence time

Residence time is an important reaction parameter of the microreactor and also reflects the production capacity of the microreactor. It could be controlled by two parameters, the length of the reactor loop (R2) and the flow rate. In the previous experiment, 1.5 mL/min was chosen as the optimum flow rate of Me₂SO, and then the length of R2 was studied.

The residence time was investigated under the condition of *n* (Me₂SO): *n* (oxalyl chloride): *n* (benzyl alcohol) = 3:1.5:1, T = 15 °C, flow rate of Me₂SO = 1.5 mL/min. The effects of residence time were investigated by setting the length of R2 to 1.0 m, 1.5 m, 2.0 m, and 2.5 m, respectively.

2.3.2.1. Oxalyl chloride as the activator

The results are shown in Table 1. The highest yield at which oxalyl chloride acted as the activator was 70.0% (1.024 g/h) and the best selectivity was 97.3%. Increasing the length of R2 slightly from 1.0 m to 1.5 m appeared to have a negative impact on the selectivity of benzaldehyde (decreased from 97.3% to 94.1%), whereas a positive impact was shown on the yield of benzaldehyde (increased from 55.5% to 70%, 0.846 g/h to 1.024 g/h). However, when we continued to lengthen R2 from 1.5 m to 2.5 m, both the selectivity of benzaldehyde and the yield decreased, and leakage was observed at the joints between the micromixer (M1, M2) and tubes. The selectivity of benzaldehyde always decreased with the lengthening of R2. In other words, short residence time seems to play a crucial role in improving the selectivity.

2.3.2.2. *p*-TsCl as the activator

The results of *p*-TsCl activating Swern reactions are shown in Table 2. The highest yield at which *p*-TsCl acted as the activator was 15% (302 mg/h) and the best selectivity was 95.1%. In the system benzyl chloride was found as a byproduct, which was formed by halogenation of benzyl alcohol (Scheme 3). The involved chlorine in Scheme 3 was inferred to have come from HCl, which was formed by intermediate **4** (Scheme 2) or the decomposed oxalyl chloride. When we extended the length of R2 from 1.0 to 1.5 m, the yield increased by

Table 1. Influence of the length of R2 to Swern oxidation when oxalyl chloride acted as the activator. All of the yields and selectivities were determined by GC-MS with the normalization method of peak area.

The length of R2 (m)	The yield of benzyl chloride (%)	The selectivity of benzaldehyde (%)	The yield of benzaldehyde (%)
1.0	2.3	97.3	55.5 (0.846 g/h)
1.5	4.8	94.1	70.0 (1.024 g/h)
2.0	7.5	85.6	45.1 (0.655 g/h)
2.5	13.4	72.0	39.7 (0.563 g/h)

5%, and the highest yield of 15% (302 mg/h) appeared at 1.5 m. When we continued to extend the length of R2 from 1.5 to 2.5 m, the yield decreased by 7%. The selectivity always decreased with the extending of R2, from 95.1% to 70.6%. Leakage was observed after lengthening R2 over 2.0 m.

Table 2. Influence of the length of R2 to Swern oxidation when *p*-TsCl acted as the activator. All of the yields and selectivities were determined by GC-MS with the normalization method of peak area.

The length of R2 (m)	The yield of byproduct (%)	The selectivity of benzaldehyde (%)	The yield of benzaldehyde (%)
1.0	0.52	95.1	10.0 (0.196 g/h)
1.5	2	88.3	15.0 (0.302 g/h)
2.0	1.82	84.2	9.2 (0.179 g/h)
2.5	3.2	70.6	7.5 (0.143 g/h)

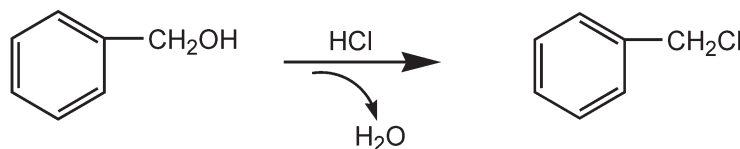
**Scheme 3.** The proposed formation mechanism of benzyl chloride in the system.

2.3.3. Optimization of the type of micromixers

Micromixers are main components of continuous microreactor systems and directly affect the mixing efficiency and the yield of products. The CPMM and SIMM were both investigated in this paper.

The internal structures of the CPMM and SIMM are shown in Figure 6. The CPMM has channel size of $600 \mu\text{m} \times 600 \mu\text{m}$ and internal volume of $30 \mu\text{L}$. It has a three-dimensional tooth profile structure, and the fluids will rotate into a vortex, which facilitates the mixing of materials. Because of its property of stainless steel, CPMM performs well in reactions of high pressure or high flow rate. There are 30 vertical channels in the SIMM and the internal volume is $5.625 \mu\text{L}$. Instead of stainless steel, the SIMM is made of special glass, so the pressure durability of the SIMM is weaker than that of the CPMM.

The effect of the SIMM and CPMM were investigated under the condition of n (Me_2SO): n (oxalyl chloride): n (benzyl alcohol) = 3:1.5:1, 15°C , and L (R2) = 1.5 m. The flow rate of Me_2SO was set to 1.2 mL/min, 1.5 mL/min, 1.8 mL/min, and 2.0 mL/min, respectively.

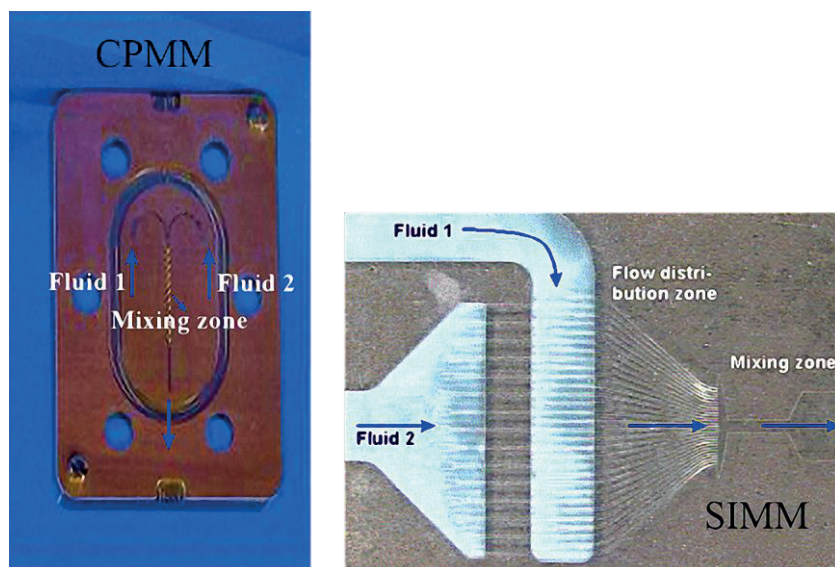

Figure 6. Internal structure and path of fluids in CPMM and SIMM.

2.3.3.1. Oxalyl chloride as the activator

The result is shown in Figure 7. When the flow rate of Me_2SO was increased from 1.2 mL/min to 1.5 mL/min, the yields of both of the two micromixers increased dramatically, and both the yields decreased at the same time when the flow rate of Me_2SO increased over 1.5 mL/min. When the flow rate of Me_2SO was between 1.5 and 2.5 mL/min, the yields of the CPMM were better than those of the SIMM, and the highest yield of benzaldehyde reached 70.0% (1.024 g/h) at 1.5 mL/min.

2.3.3.2. *p*-TsCl as the activator

Figure 8 shows the results of reactions applying the CPMM and SIMM micromixers. The yields with the CPMM increased massively when the flow rate of Me_2SO was increased from 1.2 mL/min to 1.5 mL/min. When we continued to increase the flow rate of Me_2SO , the yield decreased by 4/5. In contrast to the CPMM, the SIMM obviously acted well at low flow rate. When the flow rate of Me_2SO was 1.2 mL/min, the yield of the SIMM was higher than that of the CPMM, but as the flow rate of Me_2SO increased, the yield of the SIMM always decreased. There was almost no benzaldehyde in the system when the flow rate of Me_2SO was 2.0 mL/min. This could be attributed to the special internal structure (Figure 6), which caused the SIMM to act better at low flow velocity.

2.3.4. Optimization of the mole ratio of Me_2SO , oxalyl chloride, and benzyl alcohol

Based on the investigation above, the mole ratio of Me_2SO , oxalyl chloride, and benzyl alcohol (1:1:1, 2:1:1, 3:1.5:1, 4:2:1, 5:2.5:1, and 6:3:1) was optimized under the condition of $L(R_2) = 1.5 \text{ m}$, $15 \text{ }^\circ\text{C}$, CPMM micromixer, oxalyl chloride as activator, and Me_2SO flow rate of 1.5 mL/min. In this study, the reaction time and the concentration of Me_2SO was fixed at 40 min and 14 mmol/mL, so the concentration of oxalyl chloride and benzyl alcohol can be easily calculated according to the mole ratio. In addition, it was ensured that the excess amount of triethylamine was used for the consumption of the acid produced in reaction media and for the efficient conversion of intermediate **6** to **7** (Scheme 1). The results are shown in Table 3. When the

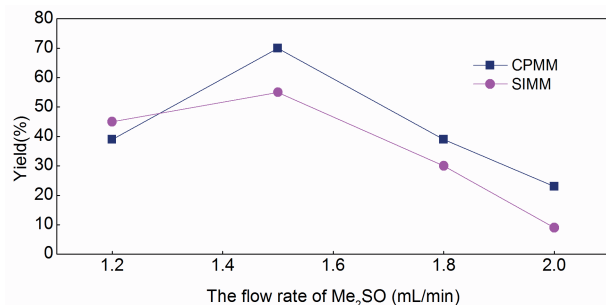

Figure 7. Influence of the types of microreactors on yield when oxalyl chloride acted as the activator.

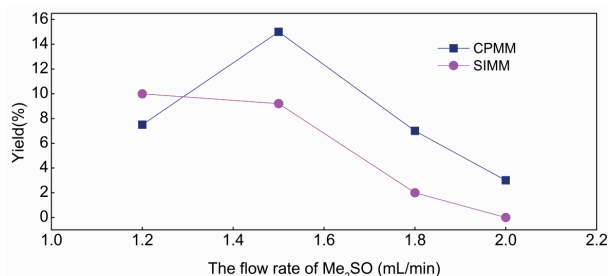

Figure 8. Influence of types of microreactors on yield when *p*-TsCl acted as the activator.

mole ratio of Me₂SO, oxalyl chloride, and benzyl alcohol was 4:2:1, the yield reached 84.7% (1.800 g/h) and the selectivity reached 98.5%, which were the best in all conditions (Table 3).

Table 3. Influence of the mole ratio of reactants (Me₂SO: oxalyl chloride: benzyl alcohol) to Swern oxidation. All of the yields and selectivities were determined by GC-MS with the normalization method of peak area.

The mole ratio of reactants	The yield of benzyl chloride (%)	The selectivity of benzaldehyde (%)	The yield of benzaldehyde (%)
1:1:1	2.9	88.5	58.9 (0.811 g/h)
2:1:1	3.5	90.4	63.1 (0.893 g/h)
3:1.5:1	4.8	94.1	70.0 (1.024 g/h)
4:2:1	6.3	98.5	84.7 (1.800 g/h)
5:2.5:1	9.1	95.9	70.9 (1.466 g/h)
6:3:1	11.3	96.8	69.4 (1.343 g/h)

2.4. Conclusions

The oxidation of benzyl alcohol to benzaldehyde was performed by Swern oxidation in a continuous flow microreactor system. The method was tested to be practical and the setup of the continuous microreactor system seems to be reasonable. Moreover, it could be applied to similar reactions that were accompanied by liable intermediates and a great deal of heat. Parameters such as reaction temperature, flow rates of reactants, types of micromixers, length of delay loops, and mole ratio of reactants were optimized and Swern oxidations activated by oxalyl chloride and *p*-TsCl were discussed, respectively. It was found that the optimized parameters of the Swern oxidation of benzyl alcohol were as follows: oxalyl chloride was applied as activating agent; the mole ratio of Me₂SO, oxalyl chloride, and benzyl alcohol was 4:2:1; the flow rate of Me₂SO was 1.5 mL/min; the reaction temperature was 15 °C; the length of the delay loop was 1.5 m; the CPMM served as the micromixer; and all of the experiments were conducted at atmospheric pressure. The yield of benzaldehyde can reach 84.7% (1.800 g/h) with a selectivity of 98.5%.

3. Experimental

3.1. Material and apparatus

Dichloromethane was distilled so that the dissolved water could be removed. The other chemicals were used as received. The related components of the continuous flow microreactor system include three LC 3000 HPLC

pumps made by Beijing Chuangxintongheng Science and Technology Co., Ltd. A 1/8 T-shaped joint (M1), a CPMM or a SIMM (M2), and several pieces of 1/12 316 stainless steel tube (R1, R2) were used, made by IMM. A water bath with constant circulation temperatures and an 85-2 type thermostat magnetism agitator from Gongyikehua Instrument Co., Ltd. were applied to control the temperature. Reactions were monitored offline by GC-MS.

3.2. Experimental procedure

The continuous flow microreactor system was assembled as shown in Figure 1. The Me₂SO, activator, and benzyl alcohol were loaded into HPLC pumps with appropriate flow rates. After a stable period of 10 min, the effluent was collected in a separation funnel through which we could observe the color and layering by controlling the valve. Then effluent was finally collected into a continuously stirred flask containing an excess amount of triethylamine. The temperatures were kept constant by a water bath with constant circulation temperatures and a thermostat magnetism agitator. All of the reactions were monitored offline by GC-MS; the yields and selectivities were calculated by the method of area normalization.

Upon completion of the reaction, the mixture of triethylamine and effluent was washed with 5% HCl and the organic layer was separated. Then the organic layer was washed 2 or 3 times until the mixture in the separation funnel reached neutral. In the process, the aqueous layers were always extracted twice with dichloromethane. At last, the organic layers were collected together and dried by anhydrous MgSO₄ for 4 h. The final product, benzaldehyde, was obtained after filtration and reduced pressure distillation.

3.3. Quantitative method

Reactions were quantified with the normalization method of peak area by GC-MS. The GC method was optimized so that all of the components were separated well and the peak of each compound appeared in the chromatogram. The samples were injected and ran according to the following method. An Agilent HP-5MS column (30 m × 0.25 mm, 0.25 μm) was used. Oven temperature was started at 50 °C and then increased to 250 °C at a rate of 15 °C/min with a final stand of 2 min. The temperature of the injection port was 250 °C and the sample size was 0.2 μL. The split ratio was set at 100:1. An EI ion source was used and the ionizing voltage and temperature of ion source was set respectively at 70 eV and 230 °C. The temperature of the quadrupole was 150 °C. The scan mode was set as Scan and the range of mass scan was 33 to 300 m/Z.

Acknowledgment

This work was financially supported by the National Key Technology R & D Program, P.R. China (2011BAD23B01).

References

1. Chandler, W. D.; Wang, Z.; Lee, D. G. *Can. J. Chem.* **2005**, *83*, 1212-1221.
2. Ara, B.; Shah, J.; Rasul J. M.; Muhammad, M. *J. Saudi Chem. Soc.* **2008**, *20*, S566-S572.
3. Patel, S.; Mishra, B. K. *Tetrahedron* **2007**, *63*, 4367-4406.
4. Basavaiah, D.; Kumaragurubaran, N.; Padmaja, K. *Synlett* **1999**, *1999*, 1630-1632.
5. Garegg, P. J.; Olsson, L.; Oscarson, S. *J. Org. Chem.* **1995**, *60*, 2200-2204.
6. Satam, V.; Harad, A.; Rajule, R.; Pati, H. *Tetrahedron* **2010**, *66*, 7659-7706.
7. Marek, A.; Klepetarova, B.; Elbert, T. *Asian J. Org. Chem.* **2015**, *4*, 808-817.

8. Leduc, A. B.; Jamison, T. F. *Org. Process Res. Dev.* **2012**, *16*, 1082-1089.
9. Han, M. K.; Kim, S.; Kim, S. T.; Lee, J. C. *Synlett* **2015**, *26*, 2434-2436.
10. Saadati, F.; Yousefi, K. *Synthetic Commun.* **2014**, *44*, 2818-2825.
11. van der Linden, J. J. M.; Hilberink, P. W.; Kronenburg, C. M. P.; Kemperman, G. J. *Org. Process Res. Dev.* **2008**, *12*, 911-920.
12. Ideue, E.; Shimokawa, J.; Fukuyama, T. *Org. Lett.* **2015**, *17*, 4964-4967.
13. Sweat, F. W.; Epstein, W. W. *J. Org. Chem.* **1967**, *32*, 835-838.
14. Tsuchiya, D.; Moriyama, K.; Togo, H. *Synlett* **2011**, *2011*, 2701-2704.
15. van den Broek, S.; Becker, R.; Koch, K.; Nieuwland, P. J. *Micromachines* **2012**, *3*, 244-254.
16. Kawaguchi, T.; Miyata, H.; Ataka, K.; Mae, K.; Yoshida, J. *Angew. Chem. Int. Ed.* **2005**, *44*, 2413-2416.
17. Mancuso, A. J.; Huang, S. L.; Swern, D. *J. Org. Chem.* **1978**, *43*, 2480-2482.
18. Watts, P.; Wiles, C. *J. Chem. Res.* **2012**, *36*, 181-193.