

Network–Oriented Modeling of Radiating Electromagnetic Structures

Peter RUSSEr

*Institute for High–Frequency Engineering,
Technische Universität München, Arcisstrasse 21, D–80333 Munich–GERMANY
e-mail: russer@ei.tum.de*

Abstract

The application of network-oriented modeling for radiating electromagnetic structures is investigated. Network methods are applied to the field problem using the segmentation technique and by specifying canonical Foster representations as compact models of reciprocal linear lossless electromagnetic structures. Connection between different subdomains is obtained via connection circuits exhibiting only ideal transformers. In the case of radiating structures, the complete structure is embedded into a sphere and the field outside the sphere is expanded into orthogonal spherical TM- and TE- waves. For each radiation mode a Cauer canonic circuit representation is given.

Key Words: *radiating electromagnetic structures, canonical Foster representation, Cauer canonic circuit*

1. Introduction

Network-oriented methods applied to electromagnetic field problems can contribute significantly to the problem formulation and solution methodology [1, 2, 3]. In network theory systematic approaches for circuit analysis are based on the separation of the circuit into the connection circuit and the circuit elements [4]. The connection circuit represents the topological structure of the circuit and contains only the connections, including ideal transformers. In the connection circuit neither energy storage nor energy dissipation occurs. The connection circuit, governed by Tellegen’s theorem [5, 6, 7] and Kirchhoff laws [4], connects the circuit elements that may be one-ports or multiports. Electromagnetic field theory and network theory are linked via method of moments [8]. In method of moments the electromagnetic field functions are represented by series expansions into basis functions. The linear systems of equations relating the expansion coefficients may be interpreted as linear circuit equations. If a rational expansion of the circuit equations exists lumped element equivalent circuits may be specified.

In analogy with network theory, individual subdomains are characterized via subdomain relations, obtained either analytically or numerically, and described in a unified format by using a generalized network formulation [3]. Arcioni et.al. have modeled waveguide circuits by segmenting the circuits into elementary blocks and representing these blocks by the \mathbf{Y} -matrices [9, 10]. After segmentation of a distributed circuit, each subdomain can be described either via its Green’s function or numerically. For any linear reciprocal lossless distributed circuit equivalent canonic Foster realizations exist [11, 12]. If we are subdividing an electromagnetic structure into subregions, equivalent Foster representations may be given for the subdomain circuits. The equivalent subdomain circuits are embedded into a connection circuit representing the

boundary surfaces. For lossy circuits extended Foster matrices may be introduced [13, 14, 15]. The Foster representations either may obtained via analytic solution of the field problem or by pole extraction from the numerical solution of the field problem.

In Section 2 the Tellegen’s Theorem is revisited from a field theoretic point of view. We discuss the generation of the connection network and the relative canonical form. In Section 3 the characterization of distributed circuits and subcircuits via Green’s functions and the relation of the canonical Foster equivalent circuit to the Green’s function representation are discussed. In Section 4 the Cauer canonic realization of radiation modes is presented. The complete equivalent circuit representation of radiating structures is discussed in Section 5.

2. The Tellegen’s Theorem and the Connection Network

2.1. Field theoretic formulation of tellegen’s theorem

Complex electromagnetic structures may be subdivided into spatial subdomains. Comparing a distributed circuit represented by an electromagnetic structure with a lumped element circuit represented by a network, the spatial subdomains may be considered as the circuit elements whereas the complete set of boundary surfaces separating the subdomains corresponds to the connection circuit [3].

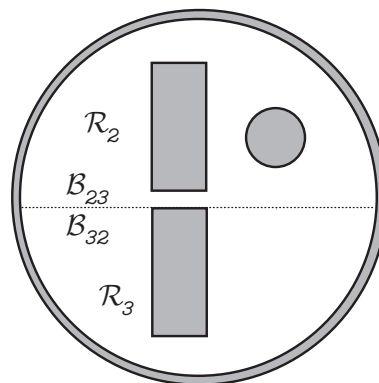

Figure 1. Segmentation of a closed structure.

Figure 1 (Figure 2) shows the segmentation of an electromagnetic closed (open) structure in different regions \mathcal{R}_l separated by boundaries \mathcal{B}_{lk} . The dashed curves denote the boundaries and shadowed regions denote perfect electric conductors or perfect magnetic conductors respectively. The nonshadowed regions may contain any electromagnetic substructure. In our network analogy the two-dimensional manifold of all boundary surfaces \mathcal{B}_{lk} represents the connection circuit whereas the subdomains \mathcal{R}_l are representing the circuit elements.

The tangential electric and magnetic fields on the boundary surface of a subdomain are related via Green’s functions [16]. These Green’s functions can be seen in analogy to the Foster representation of the corresponding reactive network.

We can establish a field representation of the Tellegen’s theorem relating the tangential electric and magnetic fields on the two-dimensional manifolds of boundaries \mathcal{B}_{lk} [7]. Expanding the tangential electric and magnetic fields on the boundaries again into basis functions allows to give an equivalent circuit representation

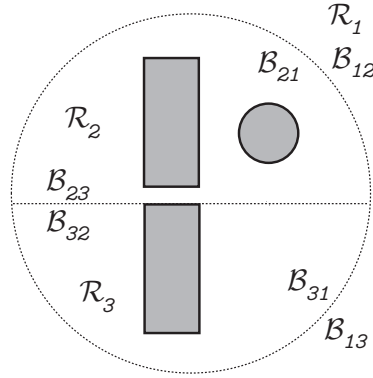

Figure 2. Segmentation of an open structure.

for the boundary surfaces. The equivalent circuit of the boundary surfaces is a connection circuit exhibiting only connections and ideal transformers.

Tellegen's theorem states fundamental relations between voltages and currents in a network and is of considerable versatility and generality in network theory [5, 6, 7]. A noticeable property of this theorem is that it is only based on Kirchhoff's current and voltage laws, i.e. on topological relationships, and that it is independent from the constitutive laws of the network. The same reasoning that yields from Kirchhoff's laws to Tellegen's theorem allows to directly derive a field form of Tellegen's theorem from Maxwell's equations [7].

In order to derive Tellegen's theorem for partitioned electromagnetic structures let us consider two electromagnetic structures based on the same partition by equal boundary surfaces. The subdomains of either electromagnetic structure however may be filled with different materials. The connection network is established via the relations of the tangential field components on both sides of the boundaries. Since the connection network exhibits zero volume no field energy is stored therein and no power loss occurs therein.

Starting directly from Maxwell's equations we may derive for a closed volume \mathcal{R}_n with boundary surface $\partial\mathcal{R}_n$ and relative normal vector \mathbf{n} the following relation:

$$\int_{\partial\mathcal{R}_n} \mathbf{E}'(\boldsymbol{\rho}, t') \times \mathbf{H}''(\boldsymbol{\rho}, t'') \cdot \mathbf{n} dA = - \int_{\mathcal{R}_n} \mathbf{E}'(\mathbf{r}, t') \cdot \mathbf{J}''(\mathbf{r}, t'') d\mathbf{r} \quad (1)$$

$$- \int_{\mathcal{R}_n} \mathbf{E}'(\mathbf{r}, t') \cdot \frac{\partial \mathbf{D}''(\mathbf{r}, t'')}{\partial t''} d\mathbf{r} - \int_{\mathcal{R}_n} \mathbf{H}'(\mathbf{r}, t') \cdot \frac{\partial \mathbf{B}''(\mathbf{r}, t'')}{\partial t''} d\mathbf{r}.$$

The prime ' and double prime '' denote the case of a different choice of sources and a different choice of materials filling the subdomains. Furthermore also the time argument may be different in both cases.

For volumes \mathcal{R}_n of zero measure or free of field the right side of this equation vanishes. Considering an electromagnetic structure as shown in Figure 1, we perform the integration over the boundaries of all subregions not filled with ideal electric or magnetic conductors respectively. The integration over both sides of a boundary yields zero contribution to the integrals on the right side of (1). Also the integration over finite volumes filled with ideal electric or magnetic conductors gives no contribution to these integrals. We obtain the field form of Tellegen's theorem:

$$\int_{\partial\mathcal{R}_n} \mathbf{E}'(\boldsymbol{\rho}, t') \times \mathbf{H}''(\boldsymbol{\rho}, t'') \cdot \mathbf{n} dA = 0. \quad (2)$$

2.2. The discretized connection network

We now consider the fields as expanded on finite orthonormal basis function sets; the assumption of orthonormal basis is not necessary, and is introduced to simplify notation. We consider a set of expansion functions of dimension N_α on side α and a basis of dimension N_β on side β .

Subject to the above assumption, we may write the transverse field expansions as

$$\left(\tilde{\mathbf{E}}_t\right)^\alpha = \sum_n^{N_\alpha} V_n^\alpha \mathbf{e}_n^\alpha(\boldsymbol{\rho}), \quad \left(\tilde{\mathbf{E}}_t\right)^\beta = \sum_m^{N_\beta} V_m^\beta \mathbf{e}_m^\beta(\boldsymbol{\rho}) \quad (3)$$

$$\left(\tilde{\mathbf{H}}_t\right)^\alpha = \sum_n^{N_\alpha} I_n^\alpha \mathbf{h}_n^\alpha(\boldsymbol{\rho}), \quad \left(\tilde{\mathbf{H}}_t\right)^\beta = \sum_m^{N_\beta} I_m^\beta \mathbf{h}_m^\beta(\boldsymbol{\rho}) \quad (4)$$

where we have used the tilde, as in [1], in order to denote fields expressed by finite expansions. The vector fields $\mathbf{e}_n^\xi(\boldsymbol{\rho})$ and $\mathbf{h}_n^\xi(\boldsymbol{\rho})$, $\xi = \alpha, \beta$, are the selected basis functions for electric and magnetic fields. Moreover, V_n^ξ and I_n^ξ , $\xi = \alpha, \beta$, denote the field amplitudes of the electric and magnetic fields, respectively. They are conveniently grouped into the following arrays for the expansions coefficients of the electric field (voltages),

$$\mathbf{V}^\alpha = \begin{bmatrix} V_1^\alpha \\ V_2^\alpha \\ \vdots \\ V_{N_\alpha}^\alpha \end{bmatrix}, \quad \mathbf{V}^\beta = \begin{bmatrix} V_1^\beta \\ V_2^\beta \\ \vdots \\ V_{N_\beta}^\beta \end{bmatrix} \quad (5)$$

and for the magnetic fields (currents),

$$\mathbf{I}^\alpha = \begin{bmatrix} I_1^\alpha \\ I_2^\alpha \\ \vdots \\ I_{N_\alpha}^\alpha \end{bmatrix}, \quad \mathbf{I}^\beta = \begin{bmatrix} I_1^\beta \\ I_2^\beta \\ \vdots \\ I_{N_\beta}^\beta \end{bmatrix} \quad (6)$$

leading compactly to

$$\mathbf{V} = \begin{bmatrix} \mathbf{V}^\alpha \\ \mathbf{V}^\beta \end{bmatrix}, \quad \mathbf{I} = \begin{bmatrix} \mathbf{I}^\alpha \\ \mathbf{I}^\beta \end{bmatrix} \quad (7)$$

2.3. Tellegen's theorem for discretized fields

We start by expanding the fields in (2) into basis functions:

$$\begin{aligned} \int_{\partial\mathcal{R}} \mathbf{E}'(\boldsymbol{\rho}, t') \times \mathbf{H}''(\boldsymbol{\rho}, t'') \cdot \mathbf{n} d\mathcal{A} &= \sum_n^{N_\alpha} \sum_m^{N_\alpha} V_m^{\alpha'}(t') I_n^{\alpha''}(t'') \int_{\partial\mathcal{R}} \mathbf{e}_m^\alpha \times \mathbf{h}_n^\alpha \cdot \mathbf{n} d\mathcal{A} \\ &+ \sum_n^{N_\beta} \sum_m^{N_\beta} V_m^{\beta'}(t') I_n^{\beta''}(t'') \int_{\partial\mathcal{R}} \mathbf{e}_m^\beta \times \mathbf{h}_n^\beta \cdot \mathbf{n} d\mathcal{A} = 0. \end{aligned} \quad (8)$$

By introducing the matrix Λ with elements

$$\Lambda_{mn}^\xi = \int_{\partial\mathcal{R}} \mathbf{e}_m^\xi \times \mathbf{h}_n^\xi \cdot \mathbf{n} d\mathcal{A}, \quad (9)$$

with ξ standing for either α or β , the general form of Tellegen's theorem is

$$\mathbf{V}'^T(t') \mathbf{I}''(t'') = 0. \quad (10)$$

In general it is convenient to consider orthogonal electric and magnetic field expansions; when this is not the case a suitable orthogonalization process can be carried out providing an orthogonalized basis. In that case the Tellegen's theorem takes the standard form

$$\mathbf{V}'^T(t') \mathbf{I}''(t'') = 0. \quad (11)$$

where $\underline{\mathbf{V}}(t)$ and $\underline{\mathbf{I}}(t)$ denote the voltage and current vectors of the connection circuit. The prime ' and double prime '' again denote different circuit elements and different times in both cases. It is only required that the topological structure of the connection circuit remains unchanged. We can relate the field formulation of the Tellegen's theorem, (2) to the network formulation (11) via the Method of Moments. Expanding the electric and magnetic field intensities into a series of basis functions, the expansion coefficients may be considered as generalized voltages and currents. If (2) holds for the field functions, (11) will be valid for the generalized voltages and currents.

2.4. Canonical forms of the connection network

Consistent choices of independent and dependent fields do not violate Tellegen's theorem and allow to draw canonical networks, which are based only on connections and ideal transformers. Figure 3 shows the canonical form of the connection network when using as independent fields the vectors \mathbf{V}^β (dimension N_β) and \mathbf{I}^α (dimension N_α). In this case the dependent fields are \mathbf{V}^α (dimension N_α) and \mathbf{I}^β (dimension N_β). In all cases we have $N_\beta + N_\alpha$ independent quantities and the same number of dependent quantities. Note that scattering representations are also allowed and that the connection network is frequency independent. It is apparent from the canonical network representations that the scattering matrix is symmetric, $\underline{\mathbf{S}}^T = \underline{\mathbf{S}}$, orthogonal, $\underline{\mathbf{S}}^T \underline{\mathbf{S}} = \underline{\mathbf{I}}$ and unitary, i.e. $\underline{\mathbf{S}} \underline{\mathbf{S}}^\dagger = \underline{\mathbf{I}}$, where the \dagger denotes the hermitian conjugate matrix.

3. The Characterization of Circuits and Subcircuits

3.1. The green's function representation

We now consider a domain \mathcal{R}_n , see Figure 1, with the tangential electric and magnetic field components on the boundary $\partial\mathcal{R}_n$ given by \mathbf{E}_t and \mathbf{H}_t . These tangential field components are related via

$$\mathbf{E}_t(\mathbf{x}, \omega) = \int_{\partial\mathcal{R}_n} \underline{\mathbf{Z}}(\mathbf{x}, \mathbf{x}', \omega) \mathbf{H}_t(\mathbf{x}', \omega) d\mathcal{A} \quad (12)$$

or

$$\mathbf{H}_t(\mathbf{x}, \omega) = \int_{\partial\mathcal{R}_n} \underline{\mathbf{Y}}(\mathbf{x}, \mathbf{x}', \omega) \mathbf{E}_t(\mathbf{x}', \omega) d\mathcal{A} \quad (13)$$

where $\underline{\mathbf{Z}}(\mathbf{x}, \mathbf{x}', \omega)$ and $\underline{\mathbf{Y}}(\mathbf{x}, \mathbf{x}', \omega)$ are the dyadic Green's functions in the impedance representation or admittance representation, respectively. The Green's functions $\underline{\mathbf{Z}}(\mathbf{x}, \mathbf{x}', \omega)$ and $\underline{\mathbf{Y}}(\mathbf{x}, \mathbf{x}', \omega)$ are given by [17]

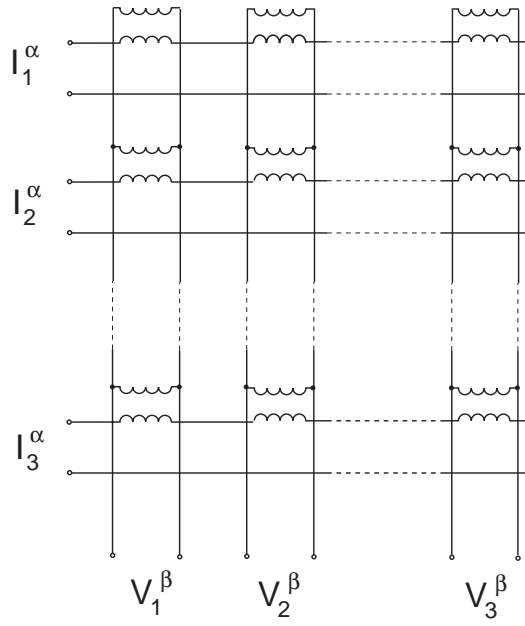

Figure 3. Canonical form of the connection network.

$$\underline{\underline{\mathbf{Z}}}(\mathbf{x}, \mathbf{x}', \omega) = \frac{1}{j\omega} \underline{\underline{\mathbf{z}}}^0(\mathbf{x}, \mathbf{x}') + \sum_{\lambda} \frac{1}{j\omega} \frac{\omega^2}{\omega^2 - \omega_{\lambda}^2} \underline{\underline{\mathbf{z}}}^{\lambda}(\mathbf{x}, \mathbf{x}') \quad (14)$$

and

$$\underline{\underline{\mathbf{Y}}}(\mathbf{x}, \mathbf{x}', \omega) = \frac{1}{j\omega} \underline{\underline{\mathbf{y}}}^0(\mathbf{x}, \mathbf{x}') + \sum_{\lambda} \frac{1}{j\omega} \frac{\omega^2}{\omega^2 - \omega_{\lambda}^2} \underline{\underline{\mathbf{y}}}^{\lambda}(\mathbf{x}, \mathbf{x}') . \quad (15)$$

The dyadics $\underline{\underline{\mathbf{z}}}^0(\mathbf{x}, \mathbf{x}')$ and $\underline{\underline{\mathbf{y}}}^0(\mathbf{x}, \mathbf{x}')$ represent the static parts of the Green's functions, whereas each term $\underline{\underline{\mathbf{z}}}^{\lambda}(\mathbf{x}, \mathbf{x}')$ and $\underline{\underline{\mathbf{y}}}^{\lambda}(\mathbf{x}, \mathbf{x}')$, respectively, corresponds to a pole at the frequency ω_{λ} .

We discretize (12) and (13) by expanding the tangential fields on $\partial\mathcal{R}_n$ into a complete set of vector orthonormal basis functions. These expansions need only to be valid on $\partial\mathcal{R}_n$,

$$\mathbf{E}_t(\mathbf{x}, \omega) = \sum_n E_n(\omega) \mathbf{u}_n(\mathbf{x}), \quad (16)$$

$$\mathbf{H}_t(\mathbf{x}, \omega) = \sum_n E_n(\omega) \mathbf{v}_n(\mathbf{x}). \quad (17)$$

The vector basis functions $\mathbf{u}_n(\mathbf{x})$ and $\mathbf{v}_n(\mathbf{x})$ fulfill the orthogonality relations

$$\int_{\partial\mathcal{R}_n} \mathbf{u}_m^*(\mathbf{x}) \cdot \mathbf{u}_n(\mathbf{x}) dA = \delta_{mn}, \quad (18)$$

$$\int_{\partial\mathcal{R}_n} \mathbf{v}_m^*(\mathbf{x}) \cdot \mathbf{v}_n(\mathbf{x}) dA = \delta_{mn}. \quad (19)$$

Furthermore the two sets of vector basis functions $\mathbf{u}_n(\mathbf{x})$ and $\mathbf{v}_n(\mathbf{x})$ are related via

$$\mathbf{v}_n(\mathbf{x}) = \mathbf{n}(\mathbf{x}) \times \mathbf{u}_n(\mathbf{x}), \quad (20)$$

$$\mathbf{u}_n(\mathbf{x}) = \mathbf{n}(\mathbf{x}) \times \mathbf{v}_n(\mathbf{x}), \quad (21)$$

where $\mathbf{n}(\mathbf{x})$ is the normal vector on $\partial\mathcal{R}_n$. The expansion coefficients E_n and H_n may be considered as generalized voltages and currents. From (16) and (17) and the orthogonality relations (18) and (19) we obtain

$$E_n(\omega) = \int_{\partial\mathcal{R}_n} \mathbf{u}_n^*(\mathbf{x}) \cdot \mathbf{E}_t(\mathbf{x}, \omega) d\mathcal{A}, \quad (22)$$

$$H_n(\omega) = \int_{\partial\mathcal{R}_n} \mathbf{v}_n^*(\mathbf{x}) \cdot \mathbf{H}_t(\mathbf{x}, \omega) d\mathcal{A}. \quad (23)$$

If the domain \mathcal{R} is partially bounded by an ideal electric or magnetic wall \mathbf{E}_t or \mathbf{H}_t respectively vanish on these walls. If the independent field variable vanishes on the boundary, this part of the boundary does not need to be represented by the basis functions. If only electric walls are involved, the admittance representation of the Green's function will be appropriate, and if only magnetic walls are involved, the impedance representation will be appropriate. Let us consider the domain in Figure 1. In this case, the main part of the boundary $\partial\mathcal{R}$ is formed by an electric wall. Only ports 1 and 2 are left open. Choosing the admittance representation, we only need to expand the field on the port surfaces into basis functions. Applying the method of moments, we obtain

$$Z_{m,n}(\omega) = \int_{\partial\mathcal{R}_n} \mathbf{u}_m^*(\mathbf{x}) \cdot \underline{\underline{\mathbf{Z}}}(\mathbf{x}, \mathbf{x}', \omega) \cdot \mathbf{v}_n(\mathbf{x}) d\mathcal{A}, \quad (24)$$

$$Y_{m,n}(\omega) = \int_{\partial\mathcal{R}_n} \mathbf{v}_m^*(\mathbf{x}) \cdot \underline{\underline{\mathbf{Y}}}(\mathbf{x}, \mathbf{x}', \omega) \cdot \mathbf{u}_n(\mathbf{x}) d\mathcal{A}. \quad (25)$$

Then from (14) and (15), the impedance matrix $Z_{m,n}(\omega)$ and the admittance matrix $Y_{m,n}(\omega)$ may be represented by

$$Z_{m,n}(\omega) = \frac{1}{j\omega} z_{mn}^0 + \sum_{\lambda} \frac{1}{j\omega} \frac{\omega^2}{\omega^2 - \omega_{\lambda}^2} z_{mn}^{\lambda}, \quad (26)$$

$$Y_{m,n}(\omega) = \frac{1}{j\omega} y_{mn}^0 + \sum_{\lambda} \frac{1}{j\omega} \frac{\omega^2}{\omega^2 - \omega_{\lambda}^2} y_{mn}^{\lambda}. \quad (27)$$

3.2. The foster canonic realization of distributed lossless reciprocal circuits

For a linear reciprocal lossless multiport an equivalent circuit model may be specified by the canonical Foster representation [11], [12]. Figure 4a shows a *compact reactance multiport* describing a pole at the frequency ω_{λ} . This compact multiport consists of one series resonant circuit and M ideal transformers. The admittance matrix of this compact multiport is given by

$$\underline{\underline{\mathbf{Y}}}_{\lambda}(\omega) = \frac{1}{j\omega L_{\lambda}} \frac{\omega^2}{\omega^2 - \omega_{\lambda}^2} \underline{\underline{\mathbf{A}}}_{\lambda} \quad (28)$$

with the real frequency-independent rank 1 matrix $\underline{\mathbf{A}}_l$ given by

$$\underline{\underline{\mathbf{A}}}_\lambda = \begin{bmatrix} n_{\lambda 1}^2 & n_{\lambda 1}n_{\lambda 2} & \dots & n_{\lambda 1}n_{\lambda N} \\ n_{\lambda 2}n_{\lambda 1} & n_{\lambda 2}^2 & \dots & n_{\lambda 2}n_{\lambda N} \\ \vdots & \vdots & \ddots & \vdots \\ n_{\lambda N}n_{\lambda 1} & n_{\lambda N}n_{\lambda 2} & \dots & n_{\lambda N}^2 \end{bmatrix}. \quad (29)$$

The $n_{\lambda i}$ are the turns ratios of the ideal transformers in Figure 4a. A compact reactance multiport describing a pole at the frequency $\omega = 0$ is shown in Figure 4b. The admittance matrix of this compact multiport is given by

$$\underline{\underline{\mathbf{Y}}}_0 = \frac{1}{j\omega L_0} \underline{\underline{\mathbf{A}}}_0, \quad (30)$$

where $\underline{\underline{\mathbf{A}}}_0$ is a real frequency independent rank 1 matrix as defined in (29). If the admittance matrix is of rank higher than 1 it has to be decomposed into a sum of rank 1 matrices. Each rank 1 matrix corresponds to a compact multiport.

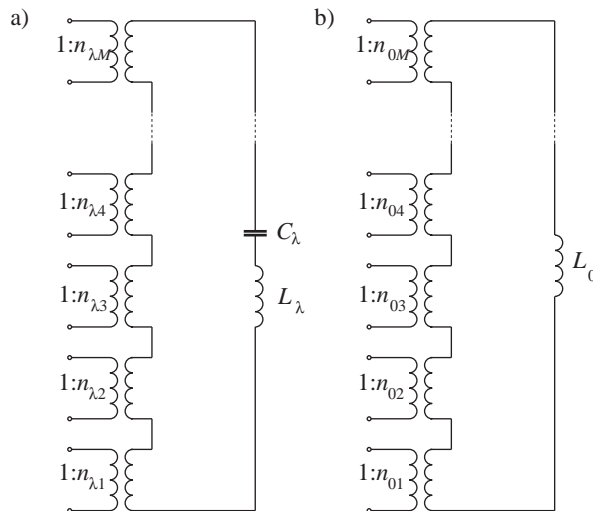

Figure 4. A compact series multiport element representing a pole a) at $\omega = \omega_\lambda$ and b) at $\omega = 0$.

The complete admittance matrix describing a circuit with a finite number of poles is obtained by parallel connecting the circuits describing the individual poles. In the *canonical Foster admittance representation*, the admittance matrix $\mathbf{Y}(p)$ is given by

$$\underline{\underline{\mathbf{Y}}}_\lambda(\omega) = \frac{1}{j\omega L_0} \underline{\underline{\mathbf{A}}}_0 + \sum_{\lambda=1}^N \frac{1}{j\omega L_\lambda} \frac{\omega^2}{\omega^2 - \omega_\lambda^2} \underline{\underline{\mathbf{A}}}_\lambda. \quad (31)$$

This admittance matrix describes a parallel connection of elementary multiports, each of which consists of a series resonant circuit and an ideal transformer. Figure 5 shows the complete circuit of the canonical Foster admittance representation. There exists also a dual impedance representation where elementary circuits consisting of parallel resonant circuits and ideal transformers are connected in series. Figure 6a shows a *compact reactance multiport* describing a pole at the frequency ω_λ . This compact multiport consists

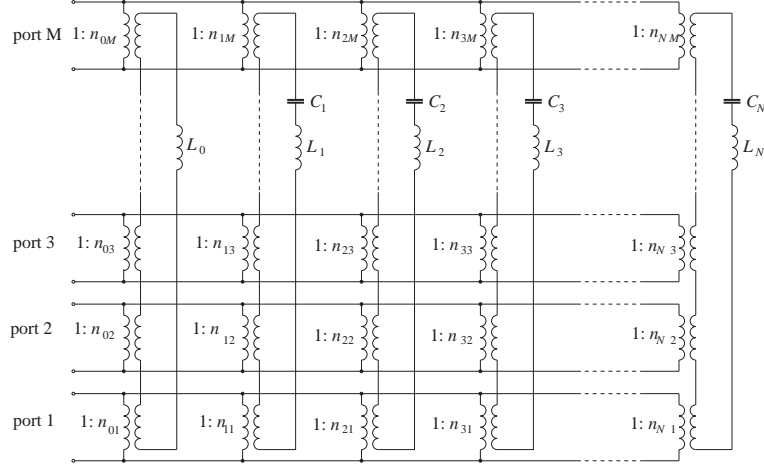

Figure 5. Foster admittance representation of a multiport.

of one parallel circuit and M ideal transformers. The impedance matrix of this compact multiport is given by

$$\underline{\underline{Z}}_{\lambda}(\omega) = \frac{1}{j\omega C_{\lambda}} \frac{\omega^2}{\omega^2 - \omega_{\lambda}^2} \underline{\underline{B}}_{\lambda} \quad (32)$$

with the real frequency independent rank 1 matrix $\underline{\underline{A}}_{\lambda}$ given by

$$\underline{\underline{B}}_{\lambda} = \begin{bmatrix} n_{\lambda 1}^2 & n_{\lambda 1} n_{\lambda 2} & \dots & n_{\lambda 1} n_{\lambda N} \\ n_{\lambda 2} n_{\lambda 1} & n_{\lambda 2}^2 & \dots & n_{\lambda 2} n_{\lambda N} \\ \vdots & \vdots & \ddots & \vdots \\ n_{\lambda N} n_{\lambda 1} & n_{\lambda N} n_{\lambda 2} & \dots & n_{\lambda N}^2 \end{bmatrix} \quad (33)$$

Figure 6b shows a *compact reactance multiport* describing a pole at the frequency $\omega = 0$. The impedance matrix of this compact multiport is given by

$$\underline{\underline{Z}}_0 = \frac{1}{j\omega C_0} \underline{\underline{B}}_0, \quad (34)$$

where $\underline{\underline{B}}_0$ is a real frequency independent rank 1 matrix as defined in (29). The complete impedance matrix describing a circuit with a finite number of poles is obtained by parallel connecting the circuits describing the individual poles. In the canonical Foster representation, the impedance matrix $\underline{\underline{Z}}(\omega)$ is given by

$$\underline{\underline{Z}}_{\lambda}(\omega) = \frac{1}{j\omega C_0} \underline{\underline{B}}_0 + \sum_{\lambda=1}^N \frac{1}{j\omega C_{\lambda}} \frac{\omega^2}{\omega^2 - \omega_{\lambda}^2} \underline{\underline{B}}_{\lambda} \quad (35)$$

The equivalent Foster admittance multiport representation or Foster impedance representation may be computed analytically from the Green's function. However it is also possible to find an equivalent Foster representation from admittance parameters calculated by numerical field analysis by methods of system identification.

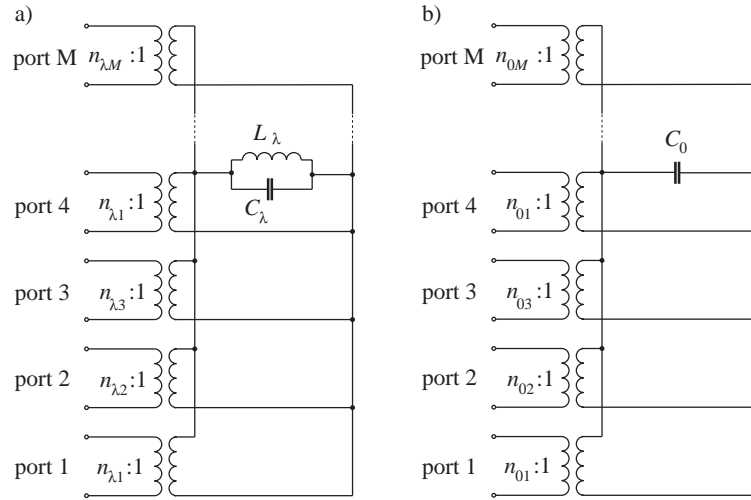

Figure 6. A compact parallel multiport element representing a pole a) at $\omega = \omega_\lambda$ and b) at $\omega = 0$.

4. The Cauer Canonic Realization of Radiation Modes

Let us assume the complete electromagnetic structure under consideration embedded in a virtual sphere \mathcal{S} as shown in Figure 8. Outside the sphere free space is assumed. The complete electromagnetic field outside the sphere may be expanded into a set of TM and TE spherical waves propagating in outward direction. In 1948 L.J. Chu in his paper on physical limitations of omni-directional antennas has investigated the orthogonal mode expansion of the radiated field [18]. Using the recurrence formula for spherical bessel functions he gave the Cauer representation [11, 12] of the equivalent circuits of the TM_n and the TE_n spherical waves. The equivalent circuit expansion of spherical waves also is treated in the books of Harrington [19] and Felsen [20].

The TM modes are given by

$$\mathbf{H}_{mn}^{TMij} = \text{rot} (A_{mn}^{ij} \mathbf{e}_r), \tag{36}$$

$$\mathbf{E}_{mn}^{TMij} = \frac{1}{j\omega\epsilon} \text{rot} \mathbf{H}_{mn}^{TMi}, \tag{37}$$

where $n = 1, 2, 3, 4, \dots$, $m = 1, 2, 3, 4, \dots, n$, $i = e, o$, and $j = 1, 2$. The radial component A_{mn}^{ij} of the vector potential is given by

$$A_{mn}^{ej} = a_{mn}^{ej} P_n^m(\cos\theta) \cos m\varphi H_n^{(j)}(kr), \tag{38}$$

$$A_{mn}^{oj} = a_{mn}^{oj} P_n^m(\cos\theta) \sin m\varphi H_n^{(j)}(kr), \tag{39}$$

where the $P_n^m(\cos\theta)$ are the associated Legendre polynomials and $H_n^{(j)}(kr)$ are the Hankel functions. The a_{mn}^{ej} and a_{mn}^{oj} are coefficients. Inward propagating waves are represented by $H_n^{(1)}(kr)$ and outward propagating waves are represented by $H_n^{(2)}(kr)$. Since outside the sphere, for $r > r_0$ no sources exist, only outward propagating waves occur and we have only to consider the Hankel functions $H_n^{(2)}(kr)$.

The TE modes are dual with respect to the TM modes and are given by

$$\mathbf{E}_{mn}^{TEij} = -\text{rot} (F_{mn}^{ij} \mathbf{e}_r), \tag{40}$$

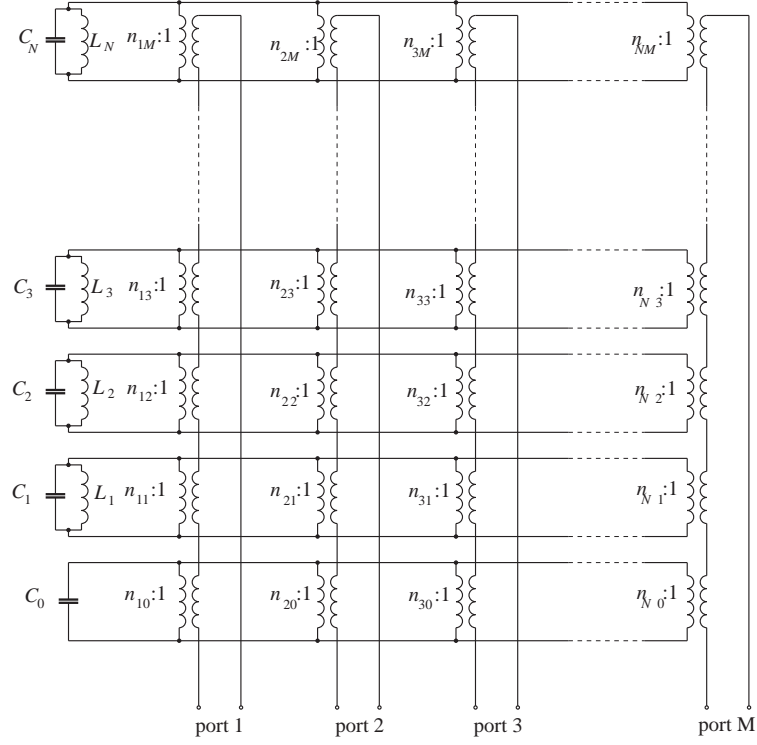

Figure 7. Foster impedance representation of a multiport

$$\mathbf{H}_{mn}^{TEij} = -\frac{1}{j\omega\varepsilon} \text{rot } \mathbf{E}_{mn}^{TMi}, \quad (41)$$

where $n = 1, 2, 3, 4, \dots$, $m = 1, 2, 3, 4, \dots, n$, $i = e, o$, and $j = 1, 2$. The radial component F_{mn}^{ij} of the dual vector potential is given by

$$F_{mn}^{ej} = f_{mn}^{ej} P_n^m(\cos\theta) \cos m\varphi H_n^{(j)}(kr), \quad (42)$$

$$F_{mn}^{oj} = f_{mn}^{oj} P_n^m(\cos\theta) \sin m\varphi H_n^{(j)}(kr). \quad (43)$$

where the $P_n^m(\cos\theta)$ are the associated Legendre polynomials and $H_n^{(j)}(kr)$ are the Hankel functions. The f_{mn}^{ej} and f_{mn}^{oj} are coefficients.

The wave impedances for the outward propagating TM and TE modes are given by

$$Z_{mn}^+ = \frac{E_{mn\theta}^+}{H_{mn\varphi}^+} = -\frac{E_{mn\varphi}^+}{H_{mn\theta}^+}, \quad (44)$$

The superscript + denotes the outward propagating wave. For the TM and TE modes we obtain

$$Z_{mn}^{+TM} = j\eta \frac{H_n^{(2)'}(kr)}{H_n^{(2)}(kr)}, \quad (45)$$

$$Z_{mn}^{+TE} = -j\eta \frac{H_n^{(2)}(kr)}{H_n^{(2)'}(kr)}, \quad (46)$$

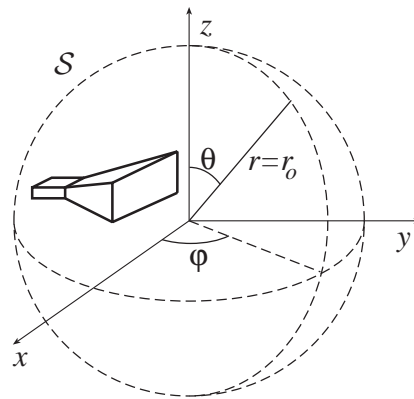

Figure 8. Embedding of an electromagnetic structure into a sphere.

where $\eta = \sqrt{\mu/\varepsilon}$ is the wave impedance of the plane wave. The prime ' denotes the derivation of the function with respect to its argument. We note that the characteristic wave impedances only depend on the index n and the radius r_0 of the sphere.

Using the recurrence formulae for Hankel functions we perform continued fraction expansions of the wave impedances of the TM modes

$$Z_{mn}^{+TM} = \eta \left\{ \frac{\frac{n}{jkr} + \frac{1}{\frac{2n-1}{jkr} + \frac{1}{\frac{2n-3}{jkr} + \dots + \frac{1}{\frac{3}{jkr} + \frac{1}{jkr+1}}}}}{\dots} \right\} \quad (47)$$

and the TE modes

$$Z_{mn}^{+TE} = \eta \left\{ \frac{\frac{1}{\frac{\frac{n}{jkr} + \frac{1}{\frac{2n-1}{jkr} + \frac{1}{\frac{2n-3}{jkr} + \frac{1}{\frac{2n-5}{jkr} + \dots + \frac{1}{\frac{3}{jkr} + \frac{1}{jkr+1}}}}}}}{\dots} \right\} \quad (48)$$

These continued fraction expansions represent the *Cauer canonic realizations* of the outward propagating TM modes (Figure 9) and TE modes (Figure 10). We note that the equivalent circuit representing the TE_{mn} mode is dual to the the equivalent circuit representing the TM_{mn} mode. The equivalent circuits for the radiation modes exhibit high-pass character. For very low frequencies the wave impedance of the TM_{mn} mode is represented by a capacitor $C_{0n} = \varepsilon r/n$ and the characteristic impedance of the TE_{mn} mode is represented by an inductor $L_{0n} = \mu r/n$. For $f \rightarrow \infty$ we obtain $Z_{mn}^{+TM}, Z_{mn}^{+TE} \rightarrow \eta$.

5. The Complete Equivalent Circuit of Radiating Electromagnetic Structures

In order to establish the equivalent circuit of a reciprocal linear lossless radiating electromagnetic structure, we embed the structure in a sphere \mathcal{S} according to Figure 11.

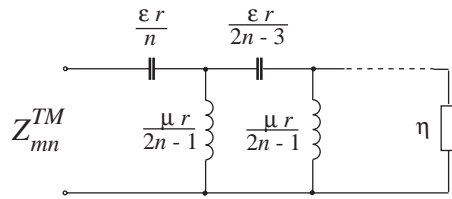

Figure 9. Equivalent circuit of TM_{mn} spherical wave.

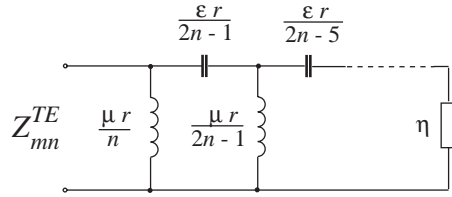

Figure 10. Equivalent circuit of TE_{mn} spherical wave.

The internal sources 1 and 2 are enclosed in regions \mathcal{R}_3 and \mathcal{R}_4 . Region \mathcal{R}_2 only contains the reciprocal passive linear electromagnetic structure. Region \mathcal{R}_1 is the infinite free space region outside the sphere \mathcal{S} . \mathcal{R}_2 may be either considered as a whole or may be subdivided into subregions. If \mathcal{R}_2 is considered as a whole it may be modelled either by a canonical Foster admittance representation according to Figure 5 or by a canonical Foster impedance representation according to Figure 7. If the internal sources are coupled via a single transverse mode with the electromagnetic structure via a single transverse mode one port per source is required to model the coupling between the source and the electromagnetic structure. The radiating modes in \mathcal{R}_1 are represented by one-ports modeled by canonical Cauer representations according to Figure 9 and Figure 10 respectively. The external ports of the canonical Foster equivalent circuit, i.e. the ports representing the tangential field on the surface of \mathcal{S} are connected via a connection network as shown in Figure 3. From the above considerations we obtain for a reciprocal linear lossless radiating electromagnetic structure with internal sources an equivalent circuit described by a block diagram as shown in Figure 12. This block structure can be further simplified by contracting the equivalent circuit describing

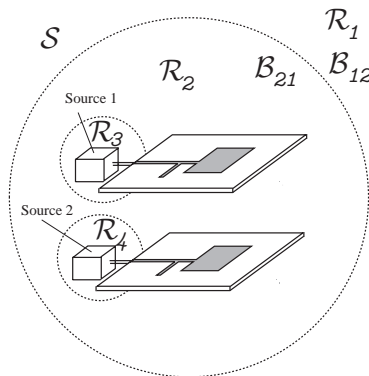

Figure 11. The complete radiating electromagnetic structure.

the electromagnetic structure \mathcal{R}_2 , the connection circuit and the reactive parts of the equivalent circuits of the radiation modes into a reactance multiport. This reactance multiport again may be represented by canonical Foster representations. Now the remaining resistors η are connected to the external ports of the modified reactance multiport and we obtain the equivalent circuit shown in Figure 13.

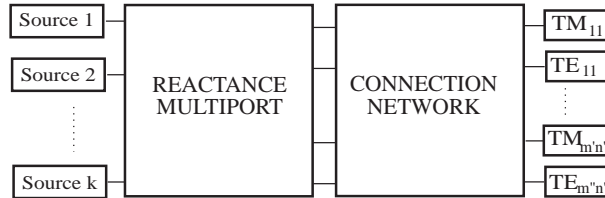

Figure 12. Equivalent circuit of the complete radiating electromagnetic structure.

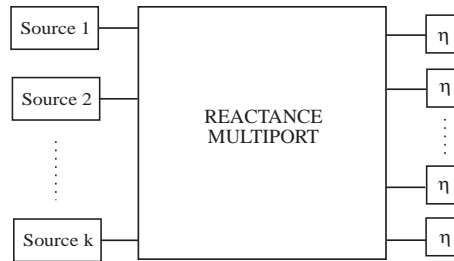

Figure 13. Equivalent circuit of the modified complete radiating electromagnetic structure.

We summarize the result of the above considerations: *Any reciprocal linear lossless radiating electromagnetic structure may be described by a reactance multiport, terminated by the sources and by one resistor for every considered radiation mode*

For electromagnetic structures amenable of analytical description equivalent circuits may be computed directly. However, topology as well as parameters of the equivalent circuit may be obtained from the relevant pole spectrum computation when a numerical solution is available [14, 15]. A heuristic approach allows also to model lossy electromagnetic structures [14, 15]. System identification and spectral analysis methods allow an efficient determination of generation of topology as well as parameters of the lumped element equivalent circuit [21, 22]. This approach produces topology as well as parameters of a model conserving basic properties like reciprocity and passivity.

6. Conclusion

A systematic approach to establish lumped element equivalent circuit representations for reciprocal linear lossless radiating electromagnetic structures has been presented. The radiating electromagnetic structure may be described by a reactance multiport, terminated by the sources and by one resistor for every considered radiation mode. The field problem is systematically treated by the segmentation technique, i.e. by dividing the overall problem space into several subregions. Connection between different subdomains is obtained by selecting the appropriate independent field quantities via Tellegen's theorem and translated to a canonical network representation providing the connection network.

If we are subdividing an electromagnetic structure into subregions, equivalent Foster representations may be given for the subdomain circuits. The equivalent subdomain circuits are embedded into a connection circuit representing the boundary surfaces. For each subdomain, as well as for the entire circuit, a frequency dependence extraction procedure has been described, which allows either in a closed form manner for subdomains amenable of analytical description or via the relevant pole spectrum computation when a numerical solution is available, system identification and generation of lumped element equivalent circuits. In the case of radiating structures, the complete structure is embedded in a sphere and the field outside the sphere is expanded into orthogonal spherical TM- and TE- waves. For each radiation mode a Cauer canonic circuit representation is given.

The described approach produces topology as well as parameters of a model conserving basic properties like reciprocity and passivity. The discussed methods allow to generate compact models of electromagnetic systems. This is extremely useful, if the electromagnetic system embedded in larger circuits or systems are considered.

References

- [1] L.B. Felsen and M. Mongiardo and P. Russer, "Electromagnetic Field Representations and Computations in Complex Structures I: Complexity Architecture and Generalized Network Formulation", *To be published in Int. J. Numerical Modelling*, 2001.
- [2] L.B. Felsen and M. Mongiardo and P. Russer "Electromagnetic Field Representations and Computations in Complex Structures II: Alternative Green's Functions", *To be published in Int. J. Numerical Modelling*, 2001.
- [3] P. Russer and M. Mongiardo and L.B. Felsen "Electromagnetic Field Representations and Computations in Complex Structures III: Network Representations of the Connection and Subdomain Circuits", *To be published in Int. J. Numerical Modelling*, 2001.
- [4] L.O. Chua and Ch.A. Desoer and E.S. Kuh, *Linear and Nonlinear Circuits*, Mc Graw Hill, New York, 1987.
- [5] B.D.H. Tellegen, "A general Network Theorem with Applications", *Philips Research Reports*, 7, pp. 259–269, 1952.
- [6] B. D. H. Tellegen, "A general Network Theorem with Applications", *Proc. Inst. Radio Engineers*, 14 , pp. 265–270, 1953.
- [7] P. Penfield and R. Spence and S. Duinker, *Tellegen's theorem and electrical networks*, MIT Press, Cambridge, Massachusetts, 1970.
- [8] R. F. Harrington, *Field computation by moment methods*, IEEE Press, San Francisco, 1968.
- [9] P. Arcioni, M. Bressan, G. Conciauro and L. Perregrini, "Wideband Modeling of Arbitrarily Shaped E-Plane Waveguide Components by the "Boundary Integral-Resonant Method",", *IEEE Trans. Microwave Theory Techn.*, vol. 44, pp. 2083–2092, Nov. 1996.
- [10] P. Arcioni and G. Conciauro, "Combination of generalized admittance matrices in the form of pole expansions," *IEEE Trans. Microwave Theory Techn.*, vol. 47, pp. 1990–1996, Oct. 1999.
- [11] W. Cauer, *Theorie der linearen Wechselstromschaltungen*, Akademie-Verlag, Berlin, 1954.
- [12] V. Belevitch, *Classical network theory*, Holden-Day, San Francisco, California, 1968.

- [13] P. Russer and M. Righi and C. Eswarappa and W.J.R. Hoefer, "Circuit parameter extraction of distributed microwave circuits via TLM simulation", *1994, Int. Microwave Symposium Digest San Diego*, pp. 887–890, May, 1994.
- [14] T. Mangold and P. Russer, "Modeling of multichip module interconnections by the TLM method and system identification", *Proc. 27th European Microwave Conference, Jerusalem*, pp. 538–543, Sept. 1997.
- [15] T. Mangold and P. Russer, "Full-wave modeling and automatic equivalent-circuit generation of millimeter-wave planar and multilayer structures," *IEEE Trans. Microwave Theory Techn.*, vo. 47, pp. 851–858, June 1999.
- [16] R.E. Collin, *Field Theory of Guided Waves*, IEEE Press, Inc., New York, First edition 1966.
- [17] R. E. Collin, *Field Theory of Guided Waves*, IEEE Press, Inc., New York Second edition, 1991.
- [18] L.J. Chu, "Physical Limitations of Omni-Directional Antennas", *J. Appl. Physics*, pp. 1163–1175, Dec, 1948.
- [19] R. F. Harrington, *Time Harmonic Electromagnetic Fields*, McGraw-Hill, New York, 1961.
- [20] L.B. Felsen and N. Marcuvitz, *Radiation and Scattering of Waves*, Prentice Hall, Englewood Cliffs, NJ, 1972.
- [21] V. Chtchekatourov and W. Fisch and F. Coccetti and P. Russer, Full-Wave Analysis and Model-Based Parameter Estimation Approaches for S- and Y- Matrix Computation of Microwave Distributed Circuits", *in 2001 Int. Microwave Symposium Digest, Phoenix*, 2001, pp. 1037–1040.
- [22] P. Russer and A.C. Cangellaris, "Network-Oriented Modeling, Complexity Reduction and System Identification Techniques for Electromagnetic Systems," *Proc. 4th Int. Workshop on Computational Electromagnetics in the Time-Domain: TLM/FDTD and Related Techniques, 17–19 September 2001 Nottingham*, pp. 105–122, Sep, 2001.