

Performance Analysis of a Fuzzy Logic Based Rotor Resistance Estimator of an Indirect Vector Controlled Induction Motor Drive

Y. MILOUD¹, A. DRAOU²

¹University Centre of Saida, BP 138, En-Nasr, Saida 20000 ALGERIA

e-mail: miloudyahiaz@yahoo.fr

²Department of Electric Engineering, University of Sciences and Technology of Oran,

B.P 1505, El Mnaouar, a Oran, ALGERIA

e-mail: adraou@yahoo.com

Abstract

This paper presents a simple method for estimating rotor resistance in an indirect vector-controlled induction motor drive. This is important in vector control, if high-performance torque control is needed. For this purpose, a rotor resistance estimator using fuzzy logic technique is used and analysis, design, and digital simulations are carried out to demonstrate the effectiveness of the proposed estimator.

1. Introduction

Indirect field oriented controlled (IFOC) induction motor drives are increasingly used in high-performance drive systems, as induction motors are more reliable because of their construction and less expensive due to the materials used, than any other motors available in the market today. Because indirect field orientation utilizes an inherent slip relation, it is essentially a feed forward scheme and hence depends greatly on the accuracy of the motor parameters used in the vector controller particularly to the rotor resistance. It changes widely with the rotor temperature, resulting in various harmful effects such as over (or under) excitation, the destruction of the decoupled condition of the flux and torque, etc. Recently, attention has been given to the identification of the instantaneous value of the rotor resistance while the drive is in normal operation. So far, several approaches have been presented.[1]-[14].

The online estimation method for static AC drives proposed by Garces in [2] uses a special adaptation function called the 'Modified Reactive Power Function' to avoid the effects of the stator resistance change. In [3], the rotor parameter estimation is proposed by estimating the rotor temperature. This is based on the fact that the heating influences the fundamental frequency component of terminal voltage for a given current input level. Lorenz in [4] developed an algorithm to correct the adverse effects of rotor resistance variations on torque and speed characteristics of motor. In [5], method used the thermal model of the induction motor to estimate at each operating point the values of stator and rotor resistances. In [6], rotor time constant measurement schemes for indirect vector control drives are proposed. The method proposed was conducted with the motor at standstill and used to adjust the slip gain for a self-tuning field-oriented

controller. The measurements are made at specified periods. The induced stator voltage is measured at every zero crossing of the phase currents and the time constant is updated for every measurement. In [7], the system is directly tuned on line for the rotor resistance variation for Direct Self-Control (DSC). DSC works for stator frequencies of up to a few Hz and can be adjusted to work at zero frequency stationary condition and locked rotor. In [8], rotor time constant measurement is proposed for an indirect vector controlled drive run by a voltage source inverter (VSI). The rotor time constant is measured from the induced stator voltage, which is measured directly using the special switching technique of the CRPWM (VSI). Similar to [6], the measurements are made at specific periods. In [9], a method for estimation of the rotor parameters in an IFOC system is proposed. In this case, the non-linear programming algorithm reconstructs the non-measurement currents using reinitialized partial moments. The electrical parameters are then estimated from the stator current model in batches. In [10], a method for the identification of rotor time constant is proposed. The identification method is an optimization problem in which the objective function is the total square error between the motor and the commanded stator currents. In [13], a new sliding mode current observer for an induction motor is developed. Sliding mode functions are chosen to determine speed and rotor resistance of an induction motor in which the speed and rotor resistance are assumed to be unknown constant parameters. In [14], a method using a programmable cascaded low pass filter for the estimation of rotor flux of an induction motor, with a view to estimate the rotor time constant of an indirect field orientation controlled induction motor drive is investigated. The estimated rotor flux data has also been used for the on-line rotor resistance identification with artificial neural network. Despite all these efforts, rotor resistance estimation remains a difficult problem.

This paper presents a method of estimation of the rotor resistance identification based on the reactive power using fuzzy logic controllers. One fuzzy controller is used to regulate the speed, and another is to correct detuning of field orientation [12]. The estimator uses available system signal: stator phase currents and stator phase voltages. The control system has been designed and the overall system has been simulated using MATLAB/SIMULINK software. Furthermore, the machine and control equations are derived, effects of the rotor resistance variations in the fuzzy controllers are presented. Simulation results show the high performance of the method used.

2. Dynamic Model of the Induction Machine

The model of the squirrel-cage induction machine can be expressed in terms of d- and q-axes quantities resulting in the following equations:

$$\dot{X} = AX + BU \quad (1)$$

Where definitions are given in (2)-(4) at the bottom of the page.

A simulation model of the induction machine has been built using the bottom equations.

$$A = \begin{bmatrix} -\frac{1}{\sigma T_s} & \omega_s + \frac{1-\sigma}{\sigma} \omega_r & \frac{L_m}{\sigma L_s T_r} & \frac{L_m}{\sigma L_s} \omega_r \\ -\omega_s - \frac{1-\sigma}{\sigma} \omega_r & -\frac{1}{\sigma T_s} & -\frac{L_m}{\sigma L_s} \omega_r & \frac{L_m}{\sigma L_s T_r} \\ \frac{L_m}{\sigma L_r T_s} & -\frac{L_m}{\sigma L_r} \omega_r & -\frac{1}{\sigma T_r} & \omega_s - \frac{1}{\sigma} \omega_r \\ \frac{L_m}{\sigma L_r} \omega_r & \frac{L_m}{\sigma L_r T_s} & -\omega_s + \frac{1}{\sigma} \omega_r & -\frac{1}{\sigma T_r} \end{bmatrix} \quad (2)$$

$$B = \frac{1}{\sigma L_s} \begin{bmatrix} 1 & 0 \\ 0 & 1 \\ -\frac{L_m}{L_r} & 0 \\ 0 & -\frac{L_m}{L_r} \end{bmatrix} \quad X = \begin{bmatrix} i_{ds} \\ i_{qs} \\ i_{dr} \\ i_{qr} \end{bmatrix} \quad U = \begin{bmatrix} V_{ds} \\ V_{qs} \end{bmatrix} \quad (3)$$

$$\sigma = 1 - \frac{L_m^2}{L_s L_r} \quad T_r = \frac{L_r}{R_r} \quad T_s = \frac{L_s}{R_s} \quad (4)$$

The electromagnetic torque and the mechanical equations can be written as follows:

$$T_e = \frac{3}{2} P L_m (i_{dr} i_{qs} - i_{qr} i_{ds}) \quad (5)$$

$$j \frac{d\Omega_r}{dt} + f \Omega_r = T_e - T_L \quad (6)$$

where j is the moment of inertia, f the viscous friction coefficient and T_L the load torque.

3. Description of the Approach Used for the Rotor Resistance Estimation

The system presently considered, shown in Figure 1, is an indirect field oriented control (IFOC)-based induction motor drive. It consists mainly of a squirrel-cage induction motor, a voltage-regulated pulse width modulated inverter, fuzzy speed controller and fuzzy rotor resistance estimator.

The induction motor is a three phase, Y connected, four pole, 1.5 Kw, 1420 rpm 220/380V, 50Hz and 6.4/3.7A.

Under field orientation condition, the d-q equations of the motor in the synchronous reference frame are:

$$R_r i_{qr} + \omega_{sl} \Psi_{dr} = 0 \quad (7)$$

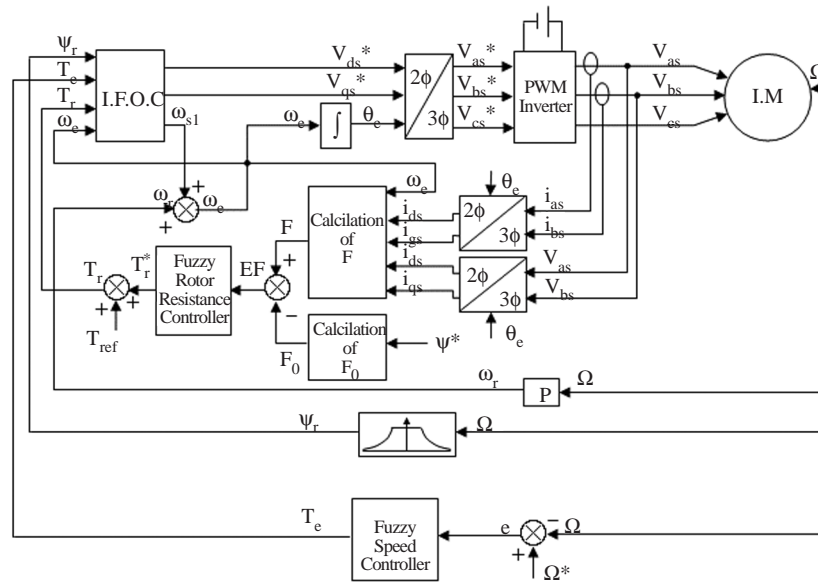

Figure 1. Proposed Scheme of Speed Control and Rotor Resistance Estimation by Fuzzy Logic Controller.

$$R_r i_{dr} + \frac{d}{dt} \psi_{dr} = 0 \tag{8}$$

$$L_m i_{qs} + L_r i_{qr} = 0 \tag{9}$$

$$L_m i_{ds} + L_r i_{dr} = \psi_{dr} \tag{10}$$

where R_r , L_r , L_m are motor parameters, i_{dr} , i_{qr} , i_{ds} , i_{qs} , ψ_{dr} , ψ_{ds} are motor currents and fluxes, and ω_{sl} is slip frequency. The equations describing the motor operation in decoupling mode are deduced from (1) - (4):

$$\omega_{sl} = \frac{L_m}{\psi_r} \left(\frac{R_r}{L_r} \right) i_{qs} \tag{11}$$

$$T_e = \frac{3}{2} p \frac{L_m}{L_r} \psi_r i_{qs} \tag{12}$$

$$\left(\frac{L_r}{R_r} \right) \frac{d\psi_r}{dt} + \psi_r = L_m i_{ds} \tag{13}$$

Because of the variation of R_r and L_r , the desired field orientation condition can not always be maintained and the drive performance can be significantly affected. For the normal operation of the drive and without considering the effects derived from the saturation (L_r constant), this rotor resistance can change up to 200% over operation.

In order to study the influence of this parameter, a characteristic function F can be defined as:

$$F = \frac{1}{\omega\omega_e} \left[\left(v_{ds} - \sigma L_s \frac{di_{ds}}{dt} \right) i_{qs} - \left(v_{qs} - \sigma L_s \frac{di_{qs}}{dt} \right) i_{ds} \right] + \sigma L_s (i_{ds}^2 + i_{qs}^2) \quad (14)$$

where ω_e is the electrical synchronous speed. This function can also be defined from a modified expression of field orientation conditions ($\psi_{qr} = 0, \psi_{dr} = \psi_r$) as follows:

$$F = \frac{L_m}{L_r} \left(\frac{d\psi_r}{dt} i_{qs} - \psi_r i_{ds} \right) \quad (15)$$

In steady state ($\frac{d\psi_r}{dt} = 0$), this equation becomes:

$$F_0 = -\frac{L_m}{L_r} \psi_r i_{ds} = -\frac{1}{L_r} (\psi_r)^2 \quad (16)$$

The error function ($EF = F - F_0$) as will be shown later by simulation reflects the rotor resistance variation [11] and can be used as a correction function for the adaptation of the rotor time constant $T_r = \frac{L_r}{R_r}$ in the fuzzy controller Figure 3 [2].

4. Rotor Esistance Estimator Using Fuzzy Logic

Figure 2 shows the configuration of the proposed fuzzy logic rotor resistance estimation. The functions F and F_0 are first calculated respectively from the estimated variables $i_{ds}, i_{qs}, v_{ds}, v_{qs}, \omega_e$ and the reference value Ψ^* .

The error EF and its time variation ΔEF are then calculated as:

$$EF(k) = F(k) - F_0(k) \quad (17)$$

$$\Delta EF(k) = EF(k) - EF(k-1) \quad (18)$$

These variables are used as inputs for the FLC. The internal structure of the fuzzy logic rotor resistance estimation is chosen similar to that of a fuzzy logic controller, which consists of fuzzification, inference engine and defuzzification. The $eF(k)$ and $\Delta eF(k)$ fuzzification stage input signals are derived from the actual $EF(k)$ and $\Delta EF(k)$ signals by dividing with the respective gain factors G_{eF} and $G_{\Delta eF}$. For the successful design of FLC's proper selection of these gains are crucial jobs, which in many cases are done through trial and error to achieve the best possible control performance. Then the crisp variables are converted into fuzzy variables eF and ΔeF using triangular membership functions as in Figure 3. These input membership functions are used to transfer crisp inputs into fuzzy sets.

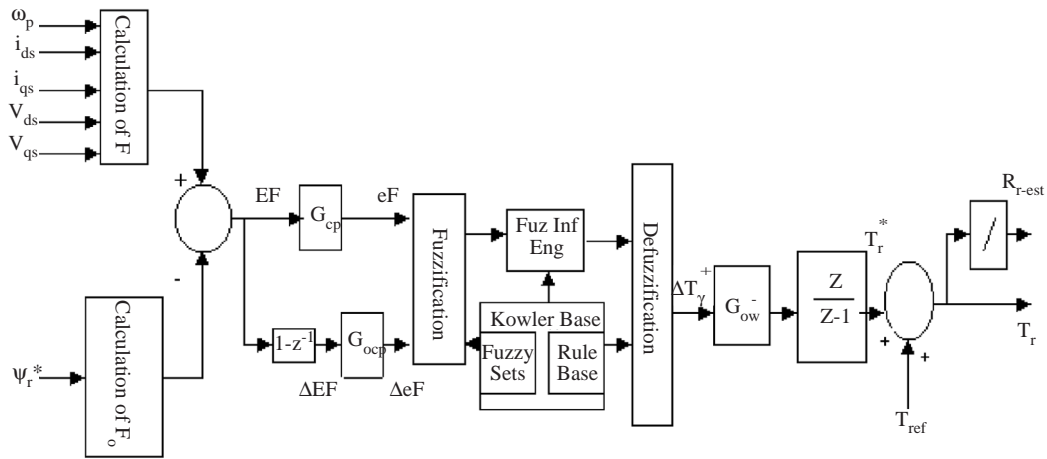

Figure 2. Fuzzy controller block diagram for rotor resistance estimation.

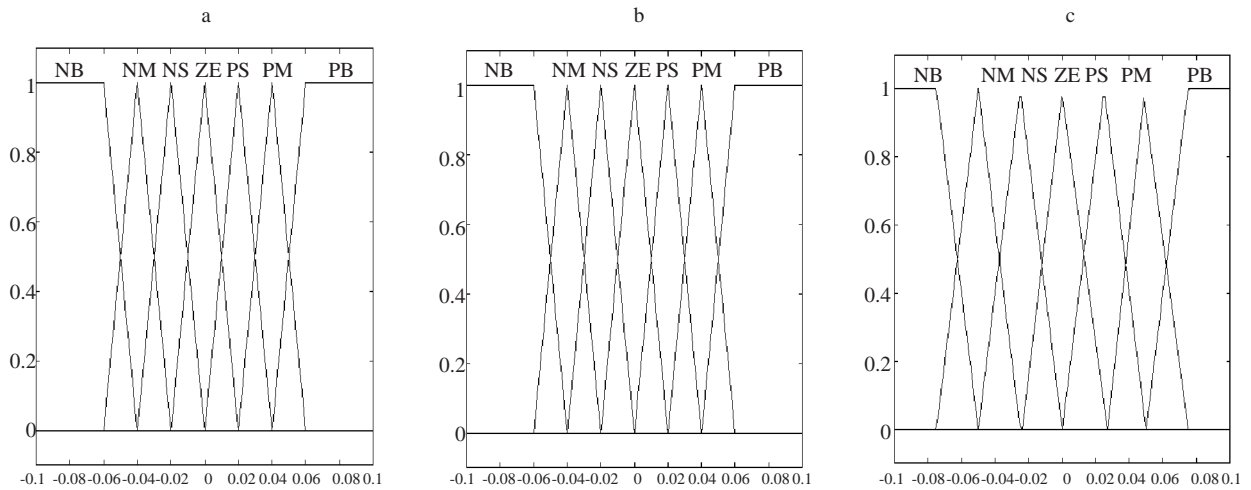

Figure 3. Input and output membership functions. (a): eF, (b): ΔeF, (c): ΔT_γ.

The expert’s experience is incorporated into a knowledge base with 49 rules (7 x 7). This experience is synthesized by the choice of the input-output (I/O) membership functions and the rule base. Then, in the second stage of the FLC, the inference engine, based on the input fuzzy variables eF and ΔeF, uses appropriate IF-THEN rules in the knowledge base to imply the final output fuzzy sets as shown in the Table 1, where NB, NM, NS, ZE, PS, PM, PB correspond to Negative Big, Negative Medium, Negative Small, Zero, Positive Small, Positive Medium, Positive Big respectively.

Table 1. Rule base for rotor resistance estimation.

ΔeF/eF	NB	NM	NS	ZE	PS	PM	PB
NM	NB	NM	NM	NS	NS	NS	ZE
NM	NM	NM	NS	NS	NS	ZE	PS
NS	NM	NM	NS	NS	ZE	PS	PM
ZE	NB	NM	NS	ZE	PS	PM	PM
PS	NS	NS	ZE	PS	PS	PM	PM
PM	NS	ZE	PS	PS	PS	PM	PM
PB	ZE	PS	PS	PM	PM	PB	PB

In the defuzzification stage, the implied fuzzy set is transformed to a crisp output by the center of gravity defuzzification technique as given by the formula (19), z_i is the numerical output at the i th number of rules and $\mu(z_i)$ corresponds to the value of fuzzy membership function at the i th number of rules. The summation is from one to n , where n is the number of rules that apply for the given fuzzy inputs [12].

$$\Delta_{\Delta} z = \frac{\sum_{i=1}^n z_i \cdot \mu(z_i)}{\sum_{i=1}^n \mu(z_i)} \quad (19)$$

The crisp output ΔT_r^* is multiplied by the gain factor $G_{\Delta T_r^*}$ and then integrated to give:

$$T_r^*(k) = T_r^*(k-1) + G_{\Delta T_r^*} \Delta T_r^*(k) \quad (20)$$

This value added to the reference rotor time constant (T_{ref}) gives the estimated time constant (T_r) which is used as an input to the F.O.C block of Figure 1 to ensure the correct field orientation operation of the drive.

Without considering the effects derived from the saturation (L_r constant), R_{r-est} is obtained from the estimated rotor time constant Figure 2. Therefore this rotor resistance estimation value used in the control model must match its real value in order to maintain a high performance of the induction motor drive as will be shown later. The input/output mapping of the FLC rotor resistance estimation is shown in Figure 4 which is a continuous highly non-linear function. Detailed discussion about FLC construction is referred in [11].

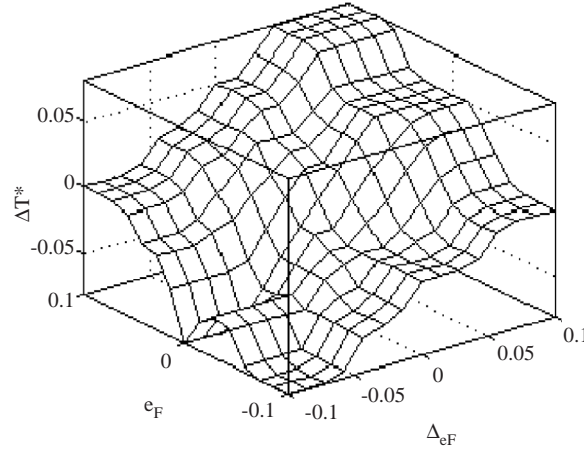

Figure 4. Crisp input/Output Map.

The same type of membership functions used in fuzzy logic rotor resistance estimation are applied in fuzzy sets for speed fuzzy logic controller. The inputs are e_1 and e_2 as defined in (21) and (22), where G_1 and G_2 are adjustable input gains.

$$e_1 = G_1 (\Omega_r^*(k) - \Omega_r(k)) \quad (21)$$

$$e_2 = G_2 (e_1(k) - e_1(k-1)) \quad (22)$$

A knowledge base of 7 x 7 rules, as shown in Table 2, is applied to tune T_e to reduce the speed error to zero. The final output of speed fuzzy logic controller is expressed in:

$$T_e(k) = T_e(k - 1) + G_{T_e^*} \cdot T_e^*(k) \tag{23}$$

These fuzzy rules can be understood easily and can be explained intuitively. For example, IF error of speed is negative big ($e_1 = \text{NB}$) and change of error is negative small ($e_2 = \text{NS}$) then it is quite natural that the fuzzified torque command should be negative big ($\Delta T_e^* = \text{NB}$). The other rules can be understood in a similar way [11].

Table 2. Rule base for speed control.

$e_2 \backslash e_1$	NB	NM	NS	ZE	PS	PM	PB
NB	NB	NB	NB	NM	NS	NS	ZE
NM	NB	NM	NM	NM	NS	ZE	PS
NS	NB	NM	NS	NS	ZE	PS	PM
ZE	NB	NM	NS	ZE	PS	PM	PB
PS	NM	NS	ZE	PS	PS	PM	PB
PM	NS	ZE	PS	PM	PM	PM	PB
PB	ZE	PS	PS	PM	PM	PB	PB

5. Simulation Results

The configuration of the overall control system is shown in Figure 1. It is essential that the simulation model is designed to approach as close to reality as possible. Therefore, for the simulation of the whole drive system according to Figure 1, a mathematical model has been developed based on the induction motor equations and the equations for estimating the rotor resistance which have been derived in Section III. In addition, a mathematical model for all the remaining drive system units was necessary to complete the simulation model.

In order to analyze the drive system performance for their flux and torque responses, with rotor resistance variation, the above-presented system has been simulated using MATLAB/SIMULINK software. A squirrel cage induction motor with a rated power of 1.5 Kw has been used. The specifications and parameters of the induction motor are listed in Appendix. A constant reference flux of 0.695 Wb is assumed and the speed was held constant at 1000 rpm. The rotor resistance was stepped or ramped from 100% to 200% of its rated value, thereby simulating a change in rotor resistance due to a temperature change. The system was first started up to 1000 rpm with a full load of 10 N.m. At 1.5 sec, the rotor resistance was stepped from 100% to 200% of its rated value. The responses of the uncompensated step case are shown in Figure 5. It is observed in this figure that when the estimated rotor resistance deviates from its real value, the field orientation scheme is detuned and the command torque (T_e) instead of stabilizing at its rated value, it is increased to 17 N.m to compensate the drop in speed which equals approximately 12 rpm.

But in the actual operating conditions, the rate of change of temperature is very slow and so the resistance variation. Figure 6 covers this situation, where at 1.5 sec a ramp change of rotor resistance for an uncompensated case is applied linearly from 100% of its rated value to 200% till 4.5 sec, then, this value is maintained for 2.5 sec.

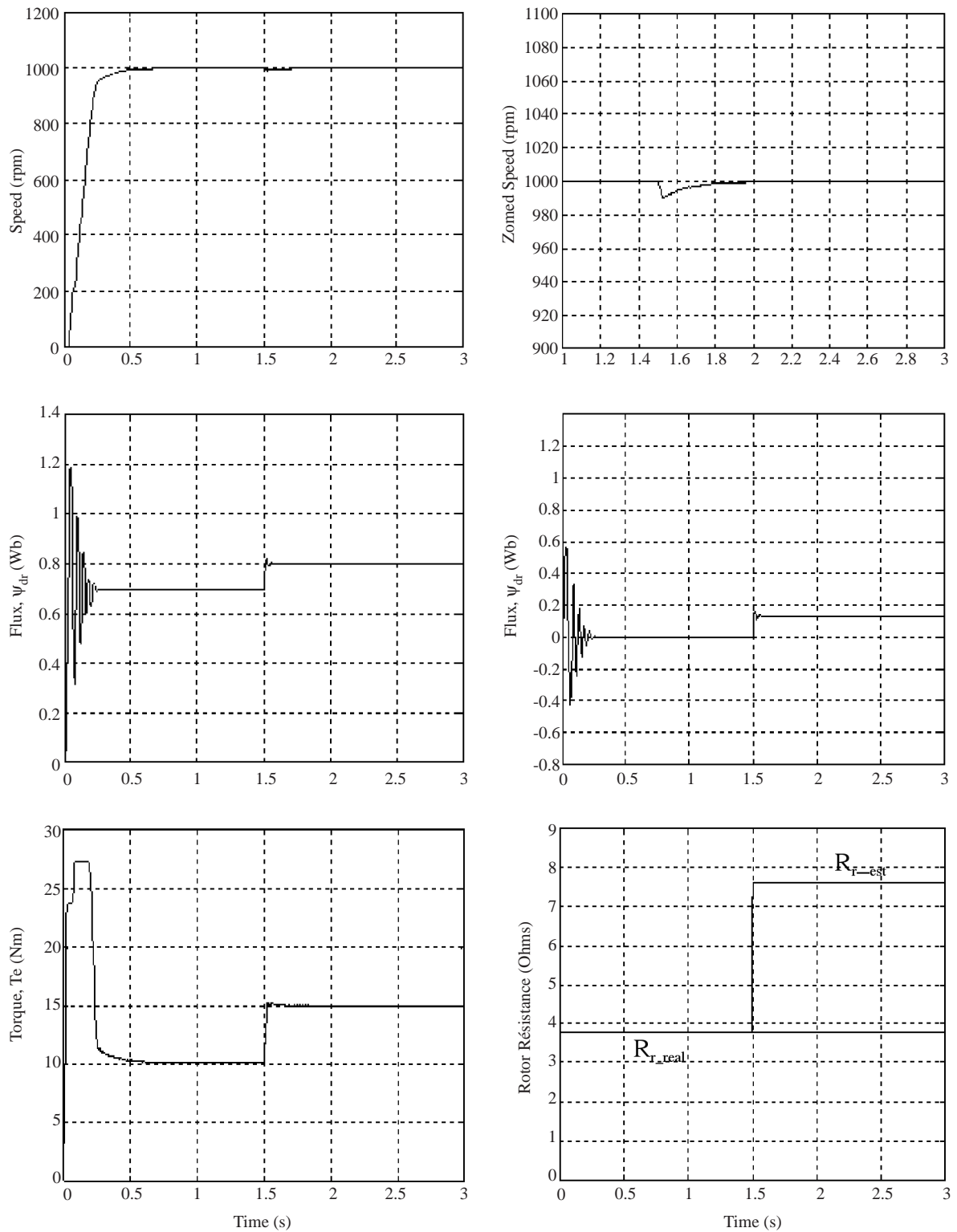

Figure 5. Waveforms illustrating the effects of step rotor resistance variation on the IM drive performance.

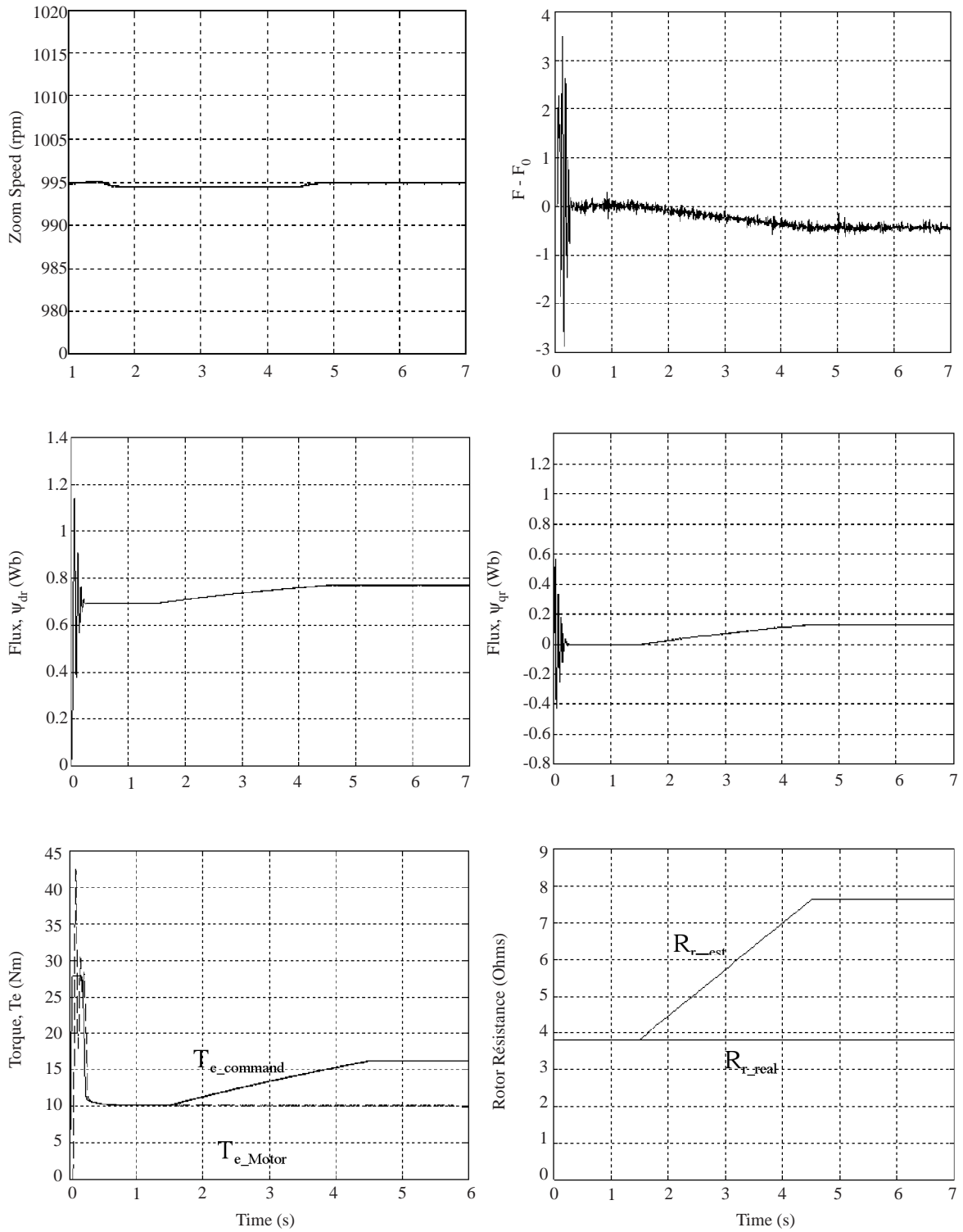

Figure 6. Effects on IM drive performance by using ramp change of rotor resistance for uncompensated case.

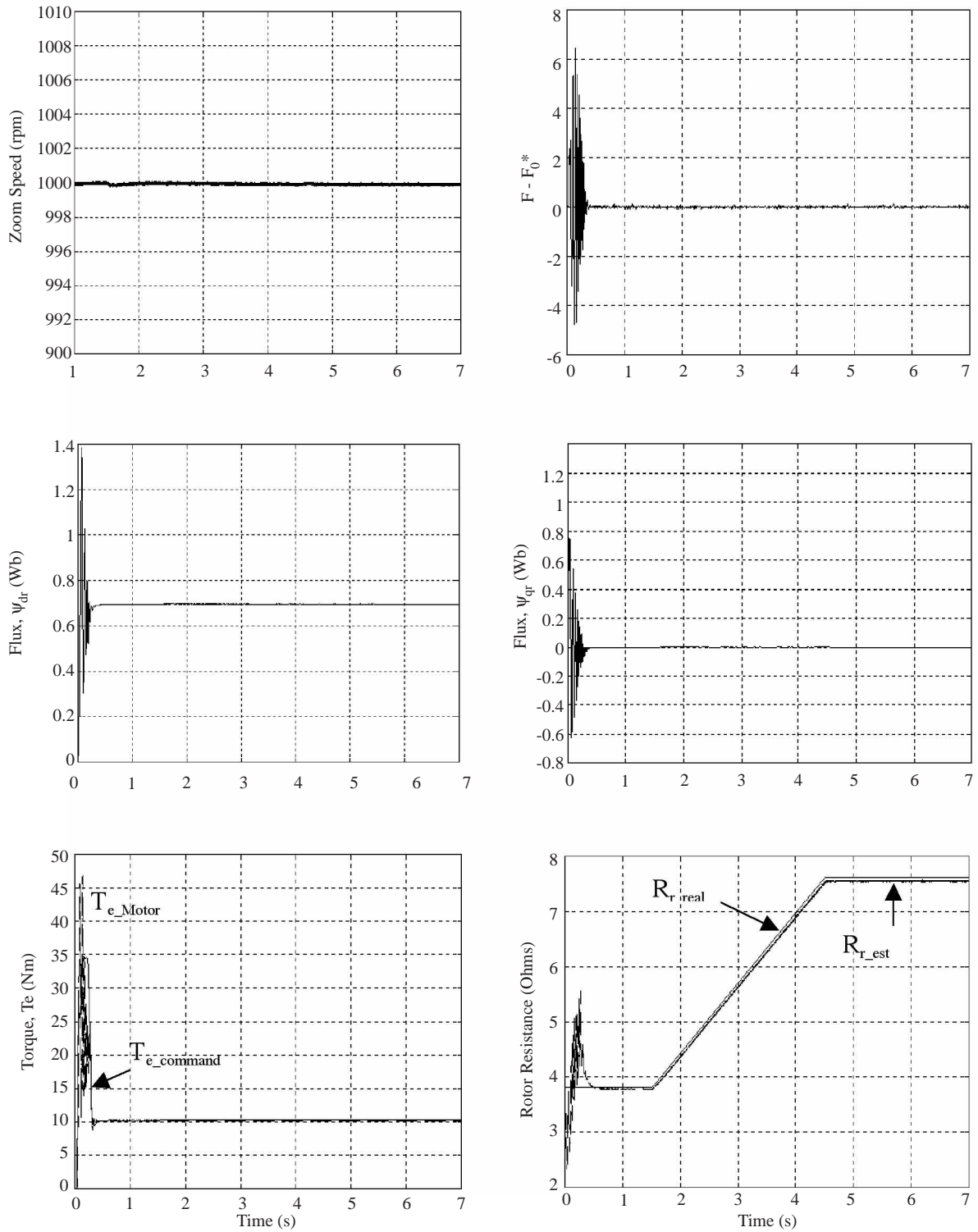

Figure 7. Effect of rotor resistance variation with Fuzzy estimator for compensated ramp change of R_r .

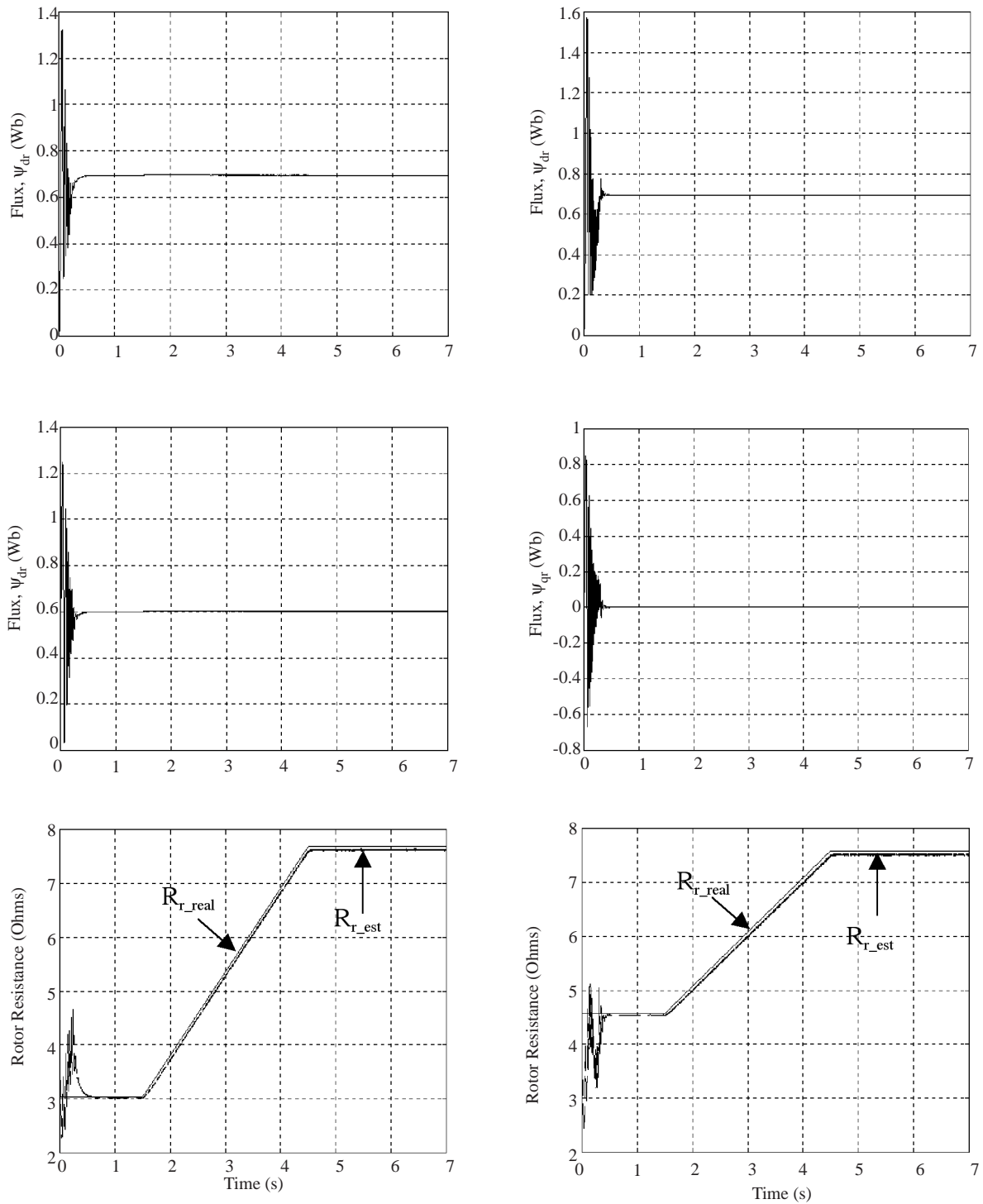

Figure 8. Performance of the fuzzy logic based rotor resistance estimator when its rated value (R_r) has changed initially to (a): -20%, (b): +20%.

We notice from this figure that the torque command deviates from the motor torque and therefore the quadratic rotor flux and the error $F - F_0$ are no longer zero. However, the performance of the control system is affected when the rotor resistance value used in the control algorithm does not match properly the real value.

Therefore in order to maintain a high performance of the induction motor drive, it is required that the rotor resistance value used in the control model should be updated regularly to track its real value. In this case, the field orientation condition can be maintained which is illustrated in Figure 7 by applying a ramp change of rotor resistance for a compensated case. In this figure, the detuned problem is removed completely and ψ_{qr} stabilizes to almost zero and ψ_{dr} to its rated value 0.695 wb. The fall in speed is negligible and excellent tracking of rotor resistance is obtained. The error $F - F_0$ is equal to zero and command torque matches perfectly the motor torque at steady state.

Then by comparing the results for uncompensated and compensated cases of a ramp change variation of rotor resistance, one can say that the association of rotor resistance estimator using fuzzy logic controller provides excellent dynamic performance to an induction motor drive.

Finally, Figure 8 demonstrates the high performance of the fuzzy logic based rotor resistance estimator when the rated value (R_r) has changed initially to $\pm 20\%$ and at the same time a ramp change of rotor resistance was applied at 1.5 sec. In both cases, the rotor resistance tracking is excellent and the field orientation condition is still maintained. However, insensitivity to the drive parameter variations and working conditions can thus be obtained. It is clear that the proposed scheme achieves good performance as it achieves compensation of the rotor resistance changes.

6. Conclusion

The variation of rotor resistance has a most important effect on the performance of indirect vector control systems. The analysis in this paper has shown that the two major effects include:

- Destroying the decoupled condition of flux and torque, hence, deteriorating the dynamic performance of the system.
- Deviation of the flux from the actual value.

Therefore, the on-line estimation of the rotor resistance is important to high performance vector control system. An on-line technique for establishing the exact value of the rotor resistance of an induction motor has been described in this paper. One fuzzy controller is used to regulate the speed, and another is to correct detuning of field orientation. Digital simulation results show that this technique can minimize the detuning effects and efficiently enhance the performance of an indirect field oriented induction motor drive. An excellent tracking performance was obtained. The general performance of the fuzzy estimator can be validated for many different sizes of motors with only the need of a simple adjustment on input and output gains

APPENDIX: Induction Motor Parameters

1.5Kw, 1420rpm	$R_s = 4.85\Omega$	$L_s = 274mH$
220/380V, 6.4/3.7A	$R_r = 3.805\Omega$	$L_r = 274mH$
3phases, 50Hz, 4poles	$L_m = 258mH$	
$J = 0.031kg.m^2$	$B = 0.00114kg.m^2/s$	

NOMENCLATURE

R_s, R_r, L_s, L_r	Stator and rotor resistances, Stator and rotor inductances
$\sigma = L_s - \frac{L_m^2}{L_r}$	Leakage inductance
T_r	Time constant
ψ_r	rotor flux component
P	Number of pole pairs
T_e	Electromagnetic torque
θ_e	Stator electrical angle
$\omega_s, \omega_r, \omega_{sl}$	Electrical synchronous speed, Electrical rotor, Slip speed
Ω_r, Ω_r^* and e	Mechanical rotor and reference speed, and Speed error
V_{ds}, V_{qs} ,	d- and q- axis stator voltages
$V_{a,b,c}$	Phase voltages in the stationary frame
$i_{ds}, i_{qs}, i_{dr}, i_{qr}$	d- and q- axis stator and rotor currents in the stationary frame

Acknowledgement

The authors would like to thank sincerely Prof. Dr. Bulent H. Ertan for his many valuable and important comments and suggestions during their stay in his laboratory, at METU, Turkey. They also would like to thank Prof. Dr. Muammer Ermis for making available his experience.

References

- [1] B.K. Bose, *Power Electronics and AC Drives*, Prentice-Hall, Englewood Cliffs, NJ: 1986.
- [2] L. J. Garces, "Parameter Adaptation for the Speed-Controlled Static AC Drive with a Squirrel-Cage Induction Motor" *IEEE Trans. Ind. Applicat.*, vol. 1A-16, N^o 2, Marsh/April 1980, pp.173-177.
- [3] F. Loser, and P. Sattler, "Identification and Compensation of the Rotor Temperature of Ac Drives by an Observer", *IEEE IAS '84*, pp. 532-537.
- [4] R. D. Lorenz, "Tuning of Field Oriented Induction motor controllers for High-Performance ",*IEEE Trans. Ind. Applic.*,vol.1A-22, pp.293-297, Mar./Apr. 1986.
- [5] Donker, D.E.R. et al, "Thermal Models of Inverter-fed Asynchronous Machines suited for Adaptive Temperature Compensation of Field Oriented Controllers, Proc of IEEE-IAS Annual Meeting, Denver, 1986, pp. 132-139.
- [6] C. Wang, D.W. Novotny, T.A. Lipo, "An Automated Rotor time Constant Measurement System for Indirect Field-Oriented Drives", *IEEE Trans. On IA*, Jan./Feb.1988, vol. 24, pp.151-159.
- [7] N.R. Klaes, "On-line Tuning of the Rotor Resistance in an Inverter Fed Induction Machines with Direct- Self-Control", *ETEP Jan'94*, vol.4.
- [8] H.A.Toliat, M.S. Arefeen, K.M. Rahman, M. Ehsani," Rotor Time Constant Updating Scheme for a Rotor Flux Oriented Induction Motor Drive" , *IEEE, PESC'95*, 1995, pp. 1302-1306.
- [9] P. coirault, J.C. Trigeassou, J.P.Gaubert, and G. Campenois, "Parameter Estimation of an Induction Machine using reinitialized Partial Moments", *4th IEEE Conf. on Control Appl.*, 1995, pp. 979-984.

- [10] Edson Bim, "Fuzzy Optimization for Rotor Constant Identification of an Indirect FOC Induction Motor Drive", IEEE Trans On Ind Elec, Dec 2001, Vol. 48, pp. 1293-1295.
- [11] Y. Miloud, A. Draou, "Fuzzy Logic Based Rotor Resistance Estimator of an Indirect Vector controlled Induction Motor Drive" Conf. Rec. IEEE/ IECON'02 Sevilla, Spain, pp. 961-967, 5-8 November 2002.
- [12] B.K. Bose, "Modern Power Electronics and AC drives", Prentice-Hall, Inc. 2002, pp.573-574.
- [13] A.Derdiyok, "Simple Method for Speed and Rotor resistance Estimation of Induction Machines", IEEE Proc-Electr, Power Appl, Vol 150, No.3, May 2003, pp 289-294.
- [14] Baburaj Karanayil, Muhammed Fazlur Rahman, nad Collin Grantham," An Implementation of a Programmable Cascaded Low-Pass Filter for a Rotor Flux Synthesizer for an Induction Motor Drive" IEEE Transactions on Power Electronics, Vol 19, No2, March 2004, pp 257-263.