

New SRCO with explicit current-mode output using two CCs and grounded capacitors

D. R. BHASKAR¹, Kasim K. ABDALLA¹, Raj SENANI²

¹*Department of Electronics and Communication Engineering,
F/O Engineering and Technology,*

*Jamia Millia Islamia, Jamia Nagar, New Delhi-110025, INDIA
e-mails: bhaskar.ec@jmi.ac.in, kasim43@yahoo.com*

²*Division of Electronics and Communication Engineering,
Netaji Subhas Institute of Technology,
Sector 3, Dwarka, Delhi 110078, INDIA
e-mail: senani@nsit.ac.in*

Abstract

A new Grounded-Capacitor Single Resistance Controlled Sinusoidal Oscillator (SRCO) with explicit current output using two Current Conveyors (CCs) and five passive elements is presented. The proposed circuit offers (i) independent control of condition of oscillation and frequency of oscillation, (ii) low active and passive sensitivities, (iii) use of both the grounded capacitors (suitable for IC implementation) and (iv) reasonably good frequency stability. The workability of the proposed configuration has been confirmed by the PSPICE simulations.

Key Words: *Analog signal processing, current conveyors, signal generators.*

1. Introduction

Single Resistance Controlled Sinusoidal Oscillators (SRCOs) find numerous applications in communication, control systems, signal processing, instrumentation and measurement systems; see [1–3] and the references cited therein. SRCOs with explicit current-mode output may be employed as test signal generators for the testing of various current-mode signal processing circuits (e.g. current-mode filters, current-mode precision rectifiers, etc.) which would otherwise require an additional voltage-to-current converter circuit when tested by using conventional mode oscillators.

Among various types of SRCOs, those which employ only two CCs and two grounded capacitors along with three grounded resistors (such as those in [4] and [5]) are particularly interesting because of the following reasons: (i) grounded capacitors are attractive for IC implementation and (ii) grounded resistors facilitate electronic control of oscillation condition and frequency of oscillation by replacing them with appropriate VCRs realized by JFETs/MOSFETs.

Although a few circuits of this kind have been proposed in the literature, they suffer from the drawbacks of non-availability of explicit current-mode output and/or employment of more than two current conveyors [6] and/or use of more complex form of CCs having multiple numbers of output terminals [7]. Some of the previously

published oscillator circuits which are capable of providing explicit current-mode output either require more than two active components (as in [8]) or employ two active components but need more number of passive components (as in [9] and [10]) or do employ one active component of a more complex nature with a larger number of terminals (see [11]) and requiring nearly as many transistors as two normal types of CCs. In this communication, we present a new circuit, which by contrast, employs only two normal types of CCs and provides explicit current output while employing five passive elements (namely, three resistors and two capacitors both of which are grounded). A comparison of component counts of the proposed oscillator and previous work is listed in Table 1.

Table 1. Comparison between various current-mode SRCOs.

Reference	No. of Active component	Active Devices	Grounded capacitors only	No. of Resistors	CM output
[4]	2	CCI & CCII	Yes	2	No
[5]	2	CCI	Yes	2	No
[6]	3	CCII	Yes	3	No
[7]	2	CCCII	Yes	-	No
[15]	1	CC-CDBA	No	-	Yes
[16]	2	PFTFN	Yes	4	Yes
[17]	3	DO-CCII	Yes	2	Yes
[18]	2	CCII+	No	4	Yes
Proposed	2	CCI & CCII	Yes	3	Yes

2. Proposed circuit

The proposed new current-mode SRCO configuration with explicit current output is shown in Figure 1. (In the following, we refer to labeled block within the figure.) Assuming the CC_{I+} is characterized by the transfer matrix

$$\begin{bmatrix} I_Y \\ V_X \\ I_Z \end{bmatrix} = \begin{bmatrix} 0 & 1 & 0 \\ 1 & 0 & 0 \\ 0 & 1 & 0 \end{bmatrix} \begin{bmatrix} V_Y \\ I_X \\ V_Z \end{bmatrix}, \tag{1}$$

and CC_{II-} is characterized by the transfer matrix

$$\begin{bmatrix} I_Y \\ V_X \\ I_Z \end{bmatrix} = \begin{bmatrix} 0 & 0 & 0 \\ 1 & 0 & 0 \\ 0 & -1 & 0 \end{bmatrix} \begin{bmatrix} V_Y \\ I_X \\ V_Z \end{bmatrix}, \tag{2}$$

a routine analysis of the circuit reveals the following characteristic equation:

$$s^2 + s \left(\frac{1}{C_1 R_3} - \frac{1}{C_1} \left(\frac{1}{R_1} + \frac{1}{R_2} \right) + \frac{1}{C_2 R_2} \right) + \frac{1}{C_1 C_2 R_2 R_3} = 0. \tag{3}$$

From this characteristic equation, when $C_1 = C_2$, the condition of oscillation (CO) is

$$R_1 \leq R_3 \tag{4}$$

and frequency of oscillation (FO) is

$$f_o = \frac{1}{2\pi} \sqrt{\frac{1}{C_1 C_2 R_2 R_3}}. \quad (5)$$

Thus, it is seen that FO can be controlled independently by R_2 and CO can be tuned by R_1 .

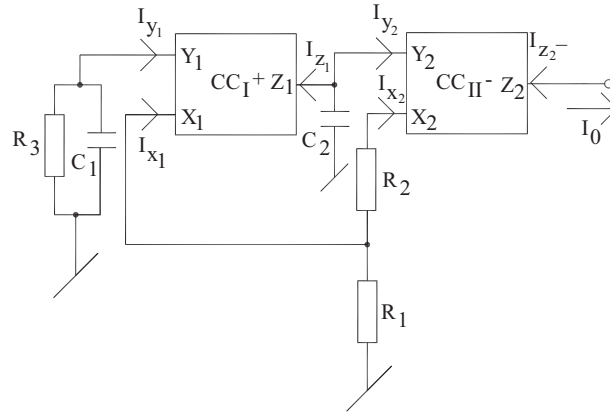

Figure 1. The proposed circuit configuration.

3. Non ideal analysis

We consider the non-idealities of CC_I and CC_{II} into account. Here, $V_{X1} = \beta_1 V_{Y1}$, $\beta_1 = (1 - \varepsilon_V)$, where ε_V ($\varepsilon_V \ll 1$) denotes the voltage tracking error of port X_1 ; $I_{Y1} = \gamma_1 I_{X1}$, $\gamma_1 = (1 - \varepsilon_i)$, where ε_i ($\varepsilon_i \ll 1$) denotes the current tracking error of port Y_1 ; $I_{Z1} = \alpha_1 I_{X1}$, $\alpha_1 = (1 - \varepsilon_i)$, where ε_i ($\varepsilon_i \ll 1$) denotes the current tracking error of port Z_1 ; $V_{X2} = \beta_2 V_{Y2}$, $\beta_2 = (1 - \varepsilon_V)$, where ε_V ($\varepsilon_V \ll 1$) denotes the voltage tracking error of port X_2 ; and $I_{Z2} = -\alpha_2 I_{X2}$, $\alpha_2 = (1 - \varepsilon_i)$, where ε_i ($\varepsilon_i \ll 1$) denotes the current tracking error of port Z_2 . The non-ideal expression for the characteristic equation is given by the relation

$$s^2 + s \left(\frac{1}{C_1 R_3} - \frac{\gamma_1 \beta_1}{C_1} \left(\frac{1}{R_1} + \frac{1}{R_2} \right) + \frac{\alpha_1 \beta_2}{C_2 R_2} \right) + \frac{\alpha_1 \beta_2}{C_1 C_2 R_2 R_3} = 0. \quad (6)$$

When $\gamma_1 \beta_1 C_2 = \alpha_1 \beta_2 C_1$, the non-ideal expressions for condition of oscillation is found to be

$$R_1 \leq \gamma_1 \beta_1 R_3, \quad (7)$$

and frequency of oscillation is found to be

$$f_o = \frac{1}{2\pi} \sqrt{\frac{\alpha_1 \beta_2}{C_1 C_2 R_2 R_3}}. \quad (8)$$

From the above, the active and passive sensitivities of the non-ideal ω_0 are given as

$$S_{C_1}^{\omega_o} = S_{C_2}^{\omega_o} = S_{R_2}^{\omega_o} = S_{R_3}^{\omega_o} = -\frac{1}{2}, \quad S_{\alpha_1}^{\omega_o} = S_{\beta_2}^{\omega_o} = \frac{1}{2}, \quad S_{\gamma_1}^{\omega_o} = S_{\alpha_2}^{\omega_o} = S_{\beta_1}^{\omega_o} = 0. \quad (9)$$

The active and passive sensitivities of ω_0 are found to be in the range $-\frac{1}{2} \leq S_x^F \leq \frac{1}{2}$, and the circuit thus enjoys low sensitivities.

4. Frequency stability

The frequency stability factor S_F is defined as [12]

$$S_F = \frac{d\Phi(u)}{du} \Big|_{u=1}, \tag{10}$$

where $u = \omega/\omega_o$ and $\Phi(u)$ denotes the phase function of the open loop transfer function of Figure 1. S_F can be found to be

$$S_F = \frac{2\sqrt{n}}{n+1}, \tag{11}$$

where $C_1 = C_2 = C$, $R_1 = R_3 = R$ and $R_2 = R/n$ for this oscillator. Maximum $S_F = 1$ is obtained when $n=1$. From (11) it is seen that S_F for the proposed circuit is at par with or better than most of the classical oscillators (such as Wien bridge, RC phase shift, etc.)

5. Simulation results

To verify the validity of the proposed configuration, circuit simulation of the current mode oscillator has been carried out using the CC_I (modified from CMOS DOCC_{II+}) and CMOS CC_{II} from [13] and [14], reproduced here in Figures 2(a) and 2(b), respectively.

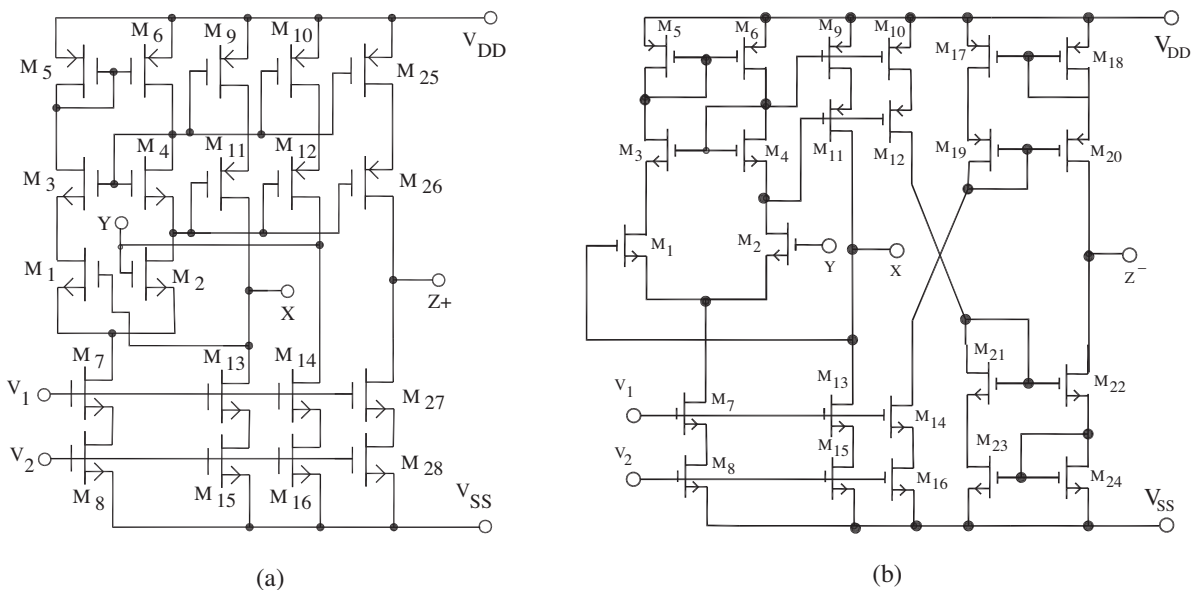

Figure 2. Current conveyor circuits: (a) CC_I + modified from DOCC_{II+}; (b) CC_{II-} .

PSPICE simulation implementation was based upon a CMOS CC_I and CC_{II} in 0.35 μ m technology. Aspect ratios of the MOSFETs are shown for CC_I and CC_{II} in Table2. The SPICE model parameters used are shown in Table 3.

Table 2. Aspect ratios of MOSFETs CC_{II} and CC_I .

MOS transistors	W/L
$M_1 - M_4$	10 / 0.35
M_5, M_6	16 / 0.35
$M_7, M_8, M_{13} - M_{16}, M_{21} - M_{24}, M_{27}, M_{28}$	5 / 0.35
$M_9 - M_{12}, M_{17} - M_{20}, M_{25}, M_{26}$	70 / 0.35

Table 3. SPICE parameters for level 3, $0.35\mu\text{m}$ CMOS process.

Parameters	NMOS	PMOS
PHI	0.7	0.7
TOX	7.9E-9	7.9E-9
XJ	3E-7	2E-7
TPG	1	-1
VTO	0.5445549	-0.7140674
DELTA	0	0
LD	3.16227E-11	5.000001E-13
WD	7.046724E-8	1.249872E-7
KP	2.055786E-4	6.733755E-5
UO	436.256147	212.2319801
THETA	0.1749684	0.2020774
RSH	0.0559398	30.0712458
GAMMA	0.5827871	0.4083894
NSUB	1E+17	1E+17
NFS	1E+12	1E+12
VMAX	8.309444E+04	1.18551E+05
ETA	0	9.999762E-4
ETA	0.2574081	1.5
KAPPA	2.82E-10	3.09E-10
CGDO	2.82E-10	3.09E-10
CGSO	1E-10	1E-10
CGBO	1E-3	1.419508E-03
CJ	0.3448504	0.5
MJ	3.777852E-10	4.813504E-10
CJSW	0.3508721	0.5
MJSW	0.9758533	0.8152753
PB		

The CMOS CC_I and CC_{II} were biased with DC power supply voltages $V_{DD} = +1.5\text{ V}$, $V_{SS} = -1.5\text{ V}$, $V_1 = -0.44\text{ V}$ and $V_2 = -0.36\text{ V}$. To achieve oscillator frequency $f_o = 1.591\text{ MHz}$, chosen component values were $R_1 = R_2 = R_3 = 1\text{ k}\Omega$, $C_1 = C_2 = 0.1\text{ nF}$. The PSPICE generated output waveforms indicate transient and steady state responses are shown in Figure 3a,b. From SPICE simulation the frequency of generated sine wave has been found to be 1.502 MHz . The Total Harmonic Distortion (THD) of the output waveform was 3%. The circuit had total power dissipation 5.6 mW and the maximum output power consumption about 0.1 mW when the output load resistance was $7\text{ k}\Omega$.

Figure 4 shows the theoretical and simulation results of the oscillation frequency by varying resistance R_2 . Simulation results which confirm the theoretical analysis are obtained. All the results confirm the workability of the proposed CM SRCO.

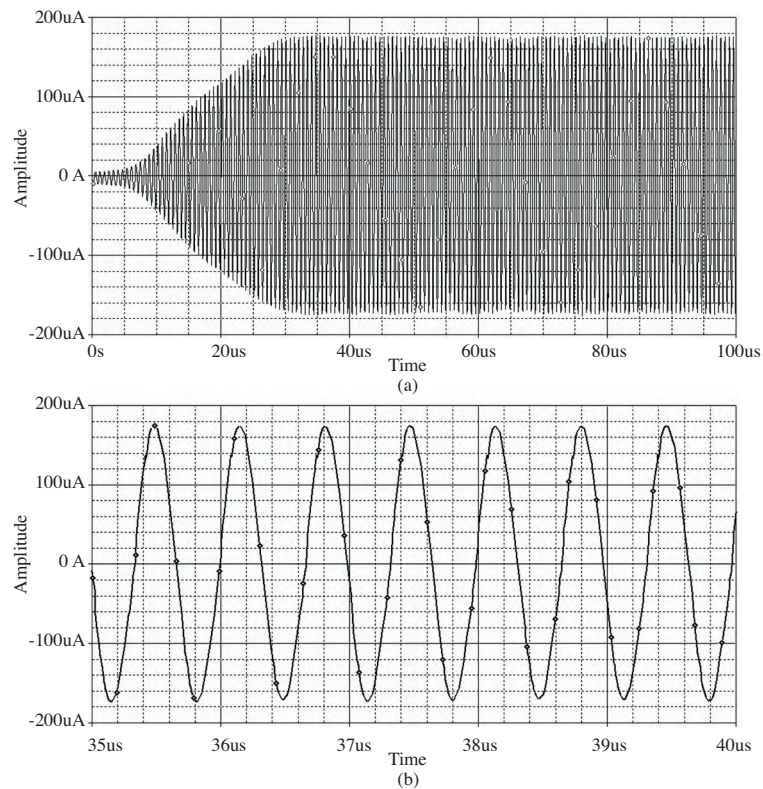

Figure 3. PSPICE Simulation results of the proposed circuit: (a) the Transient waveform, and (b) the accompanying output waveform.

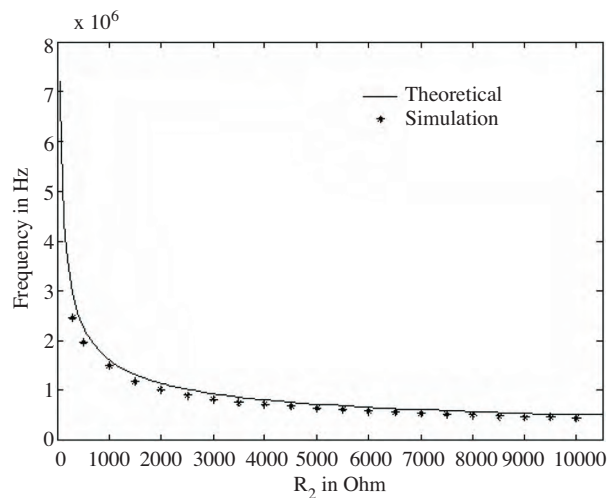

Figure 4. Variation of oscillation frequency with resistance R_2 .

6. Concluding remarks

There are a number of configurations known in the literature which realize an SRCO with explicit current output and grounded capacitors. But, such circuits usually require more than three CCs or else more complex forms of

CCs possessing multiple number of output terminals. There are other CC_I / CC_{II} based SRCO using exactly same number of active and passive components (as in the proposed circuit), such as used in [4] and [5], however such circuits do not provide explicit current output. In light of this, the new circuit has clear advantage of providing explicit current output while using only two normal kinds of CCs, both ground capacitors, a minimum number of only three resistors and providing independent control of CO and FO. Of course, there are a number of resistor-less SRCOs providing electronic control of oscillation frequency which overcome the drawback of three resistors needed in the proposed circuit; for instance see [7] and [11]. On the other hand, completely-CMOS version of the proposed circuit, providing electronic-tunability of the oscillation frequency, can be obtained by replacing all the three resistors by CMOS voltage-controlled-resistors (VCRs); in which case, it should be noted, the floating nature of frequency controlling resistor R_2 creates no obstacles, since a number of circuits are now available which can realize grounded as well as floating VCRs using exactly the same number of MOSFETs and/or other active components for instance (see [15–18]). With these modifications, the proposed circuit would become capable of providing voltage-controlled oscillation frequency.

Acknowledgement

Authors would like to take this opportunity to thank the anonymous reviewers for their very thoughtful and constructive comments and suggestions which have helped in improving the contents of the paper.

References

- [1] R. Senani, "New types of sine wave oscillators," *IEEE Trans. on Instrumentation and Measurement*, Vol. 34, no.3, pp. 461–463, September 1985.
- [2] R. Senani, D. R. Bhaskar, "Single-op-amp sinusoidal oscillators suitable for generation of very low frequencies," *IEEE Trans. on Instrumentation and Measurement*, Vol. 40, no. 4, pp. 777–779, August 1991.
- [3] D. R. Bhaskar, R. Senani, "New CFOA-based single-element-controlled sinusoidal oscillators," *IEEE Trans. on Instrumentation and Measurement*, Vol. 55, no.6, pp. 2014–2021, December 2006.
- [4] Shen-Iuan Liu, "Single-resistance-controlled/voltage-controlled oscillator using current conveyors and grounded capacitors," *Electronics Letters*, Vol. 31, no. 5, pp. 337–338, March 1995.
- [5] M.T. Abuelma'atti, A.A. Al-Ghumaiz, "Novel CC_I -based single-element-controlled oscillators employing grounded resistors and capacitors," *IEEE Transactions on Circuits and Systems I*, Vol. 43, no. 2, pp. 153–155, February 1996.
- [6] P.A. Martinez, J. Sabadell, C. Aldea, S. Celma, "Variable frequency sinusoidal oscillators based on $CC_{II} +$," *IEEE Transactions on Circuits and Systems I*, Vol. 46, no. 11, pp. 1386–1390, November 1999.
- [7] Jiun-Wei Horng, Sheng-Feng Lin, Chao-Tang Yang, "Sinusoidal oscillators using current conveyors and grounded capacitors," *Journal of Active and Passive Electronic Devices*. Vol. 2, pp. 127–136. 2007.
- [8] R. Senani, V. K. Singh, "Single-element-controlled sinusoidal oscillator employing single current conveyor IC," *Electronics Letters*, Vol. 28, no. 4, pp. 414–415, February 1992.
- [9] S. I. Liu, H. W. Tsao and J. Wu, "CCII-based continuous-time filters with reduced gain bandwidth sensitivity," *IEE Proc. Circuits, Devices Syst.* Vol. 139, PP. 210–216, 1991.

- [10] Vinod Kumar Singh, Abdhesh K. Singh, Raj Senani, "Dual function capability of recently proposed four-current-conveyor-based VM biquad," *Journal of Circuits, Systems and Computers*, Vol. 14, no. 1, pp. 51–56, 2005.
- [11] G. Moon, M.E. Zaghoul, R.W. Newcomb, "Enhancement-mode MOS voltage-controlled linear resistor with large dynamic range," *IEEE Trans. on Circuits and Systems*, Vol. 37, no. 10, pp. 1284–1288, 1990.
- [12] R. Senani, "Realization of linear voltage-controlled resistance in floating form," *Electronics Letters*, Vol. 30, no. 23, pp. 1909–1911, 1994.
- [13] H.O. Elwan, S.A. Mahmoud, A.M. Soliman, "CMOS voltage controlled floating resistor," *International Journal of Electronics*, Vol. 81, no. 5, pp. 571–576, 1996.
- [14] S.M. Al-Shahrani, "CMOS wideband auto-tuning phase shifter circuit," *Electronics Letters*, Vol. 43, no. 15, pp. 804–806, 2007.
- [15] M. Koksall, M. Sagbas and H. Sedef, "An electronically tunable oscillator using a single active device and two capacitors," *Journal of Circuits, Systems, and Computers*, vol. 17, no. 5, pp. 885–891, Oct. 2008.
- [16] D. R. Bhaskar and Raj Senani, "New FTFN-based grounded-capacitor SRCO with explicit current-mode output and reduced number of resistors," *Int. J. Electron. Commun.*, Vol. 18, No. 1, pp. 31–43, 2009.
- [17] S. Minaei, S. and E. Yuce, "All grounded passive elements current-mode All-pass filter," *Journal of Circuits, Systems and Computers*, Vol. 18, no. 1, pp.31–43, 2009.
- [18] A. M. Soliman, "Current-mode oscillators using single output current conveyors," *Microelectronics Journal*, Vol. 29, no.11, pp. 907–912, 1998.