

Design of adaptive compensators for the control of robot manipulators robust to unknown structured and unstructured parameters

Recep BURKAN*

Mechanical Engineering Department, Faculty of Engineering, İstanbul University,
34320 Avcılar, İstanbul, Turkey

Received: 20.08.2011 • Accepted: 05.12.2011 • Published Online: 22.03.2013 • Printed: 22.04.2013

Abstract: In this paper, a new adaptive-robust control approach for robot manipulators is developed. The adaptive-robust control law is not only robust to unknown structured parameters but also robust to unknown unstructured parameters such as unstructured joint friction and disturbances. The bounded disturbances and unstructured model are taken into account in a dynamic model and it is assumed that the structured and unstructured parameters are unknown. The structured and unstructured parameters are distinguished between parameters and these parameters are treated separately. Next, new parameter estimation functions are developed for each of the 2 uncertainty groups. After that, the developed dynamic adaptive compensators for the unknown structured and unknown unstructured parameters are combined and the control law is formulated by the combination of the compensators, including the proportional-derivative feedforward control. Based on the Lyapunov theory, the uniform ultimate boundedness of the tracking error is obtained.

Key words: Robust control, adaptive control, adaptive-robust control, robot control, parameter estimation, uncertainty bound estimation, Lyapunov stability

1. Introduction

Numerous adaptive and robust control methods have been developed in the past in order to increase tracking performance in the presence of parametric uncertainties. Most adaptive controls, like most parameter adaptive control algorithms, may exhibit poor robustness to unstructured dynamics and external disturbances. Some adaptive control laws, like most parameter adaptive control algorithms for robot manipulators, are given in [1–6].

Robust control laws are used for parametric uncertainty, unstructured dynamics, and other sources of uncertainties. Leitmann [7] and Corless and Leitmann [8] gave a popular approach used for designing robust controllers for robot manipulators. Some robust control laws developed based on the approaches by Leitmann [7] and Corless and Leitmann [8] are given in [9–11]. However, disturbance and unstructured dynamics are not considered in the algorithms in [9–11]. Danesh et al. [12] developed Spong's approach [9] in such a manner that the control scheme is made robust not only to uncertain inertia parameters but also to unstructured dynamics and disturbances. A robust control approach was proposed by Liu and Goldenberg [13] for robot manipulators based on a decomposition of model uncertainty. In [13], parameterized uncertainty was distinguished from unparameterized uncertainty and a compensator was designed for parameterized and unparameterized uncertainty. A decomposition-based control design framework for mechanical systems with model uncertainties was proposed by Liu [14].

*Correspondence: burkanr@istanbul.edu.tr

An adaptive scheme of the uncertainty bound was developed in [11,15–17] in order to increase the tracking performance of uncertain systems. However, a method for the derivation of the adaptive uncertainty bound estimation law was not previously proposed. A method for the derivation of the uncertainty bound estimation law was proposed in [18]. In this method, functions depending on robot kinematics and tracking error, and integration techniques, can be used for the derivation of uncertainty bound estimation laws. However, bad transient behavior was obtained in the transient state and chattering was observed in the tracking performance in [15–19]. A parameter and uncertainty bound estimation functions were developed in [19] in order to improve the tracking performance of robust controllers [9,15–18], and bad transient behavior and chattering were eliminated. In [19], only a structured dynamic model was considered, and bounded disturbances and an unstructured model were not taken into account in the dynamic model. Nominal control parameters and the upper uncertainty bound on parameters are required to be known a priori and a compensator for bounded disturbances and an unstructured model was not designed.

In this paper, a new adaptive-robust control law is considered robust to unknown structured and unstructured parameters, such as joint frictions and disturbance. The bounded disturbances and unstructured model are taken into account in a dynamic model. It is assumed that the structured and unstructured parameters are unknown. The structured and unstructured parameters are distinguished between parameters and these parameters are treated separately. Next, the adaptive dynamic compensators are developed for each of the 2 uncertainty groups. After that, the compensators for the unknown structured and unstructured parameters are combined and the control law is formulated by the combination of the compensators, including the proportional-derivative feedforward control. In previous studies [13,14], robust control input for unstructured parameters were designed. However, the upper uncertainty bound on structured and unstructured parametric uncertainties are known to be a priori and a variable function has not been used for designing the compensators for unstructured parameters. The inertia parameters and the uncertainty bound on parameters are adaptive in adaptive-robust control laws [20–22]; however, the inertia parameters are assumed to be known initially and they exist in the control law. In this paper, the structured and unstructured parameters are unknown and the inertia parameters and the upper uncertainty bound on the structured and unstructured parameters do not exist in the control law. In addition to these, a parameter estimation function is developed for the unstructured parameters, and the unstructured parameters are estimated with the estimation law in order to compensate for joint friction and external disturbance. Based on the Lyapunov theory and the Leitmann [7] or Corless and Leitmann approach [8], uniform ultimate boundedness of the tracking error is obtained.

2. Design adaptive dynamic compensators for the structured and unstructured parameters

The dynamic model of an n-link manipulator can be written as:

$$M(q)\ddot{q} + C(q, \dot{q})\dot{q} + G(q) + d = \tau. \quad (1)$$

Here, q denotes the generalized coordinates, τ is the n-dimensional vector of the applied torques (or forces), $M(q)$ is the $n \times n$ symmetric positive definite inertia matrix, $C(q, \dot{q})\dot{q}$ is the n-dimensional vector of the centripetal and Coriolis terms, $G(q)$ is the n-dimensional vector of the gravitational terms, and d is the unstructured parameters, such as the joint frictions and disturbances at the joints. Eq. (1) can be written in the following form:

$$Y(q, \dot{q}, \ddot{q})\pi + d = \tau. \quad (2)$$

Here, π is a p-dimensional vector of the inertia parameters. For any specific trajectory, the desired position, velocity, and acceleration vectors are q_d , \dot{q}_d , and \ddot{q}_d . The measured actual position and velocity errors are $\tilde{q} = q_d - q$ and $\dot{\tilde{q}} = \dot{q}_d - \dot{q}$. Using the above information, the corrected desired velocity and acceleration vectors for nonlinearities and decoupling effects are proposed as:

$$\dot{q}_r = \dot{q}_d + \Lambda \tilde{q}; \quad \ddot{q}_r = \ddot{q}_d + \Lambda \dot{\tilde{q}}. \quad (3)$$

The error σ is given as:

$$\sigma = \dot{q}_r - \dot{q} = \dot{\tilde{q}} + \Lambda \tilde{q}, \quad (4)$$

where Λ is a positive defined diagonal matrix. The following adaptive control is then defined [23]:

$$\begin{aligned} \tau_a &= \hat{M}_1(q)\ddot{q}_r + \hat{C}_1(q, \dot{q})\dot{q}_r + \hat{G}_1(q) + K\sigma \\ &= Y(q, \dot{q}, \dot{q}_r, \ddot{q}_r)\hat{\pi}_1 + K\sigma \end{aligned}, \quad (5)$$

where K is a positive defined diagonal matrix. In order to increase robustness to the parameterized and unparameterized model uncertainty, and disturbances at the joints, the following control law is proposed in terms of the adaptive control such that:

$$\begin{aligned} \tau &= \tau_a + Y(q, \dot{q}, \dot{q}_r, \ddot{q}_r)(u_1 + u_2) + u_d \\ &= \hat{M}_1(q)\ddot{q}_r + \hat{C}_1(q, \dot{q})\dot{q}_r + \hat{G}_1(q) + K\sigma + Y(q, \dot{q}, \dot{q}_r, \ddot{q}_r)(u_1 + u_2) + u_d, \\ &= Y(q, \dot{q}, \dot{q}_r, \ddot{q}_r)(\hat{\pi}_1 + u_1 + u_2) + u_d + K\sigma \end{aligned} \quad (6)$$

where u_1 and u_2 are additional inputs designed to be robust to the unknown structured parameters, and u_d is designed to be robust to unstructured parameters such as joint frictions and disturbances. Substituting Eq. (6) into Eq. (1), the following is yielded after some algebra:

$$\begin{aligned} M(q)\dot{\sigma} + C(q, \dot{q})\sigma + K\sigma &= -\tilde{M}_1(q)\ddot{q}_r - \tilde{C}_1(q, \dot{q})\dot{q}_r - \tilde{G}_1(q) - Y(q, \dot{q}, \dot{q}_r, \ddot{q}_r)(u_1 + u_2) - u_d + d \\ &= -Y(q, \dot{q}, \dot{q}_r, \ddot{q}_r)(\tilde{\pi} + u_1 + u_2) - u_d + d \end{aligned}, \quad (7)$$

where $\tilde{\pi}$ is the parameter error and is defined as [23]:

$$\tilde{\pi} = \hat{\pi}_1 - \pi. \quad (8)$$

The modeling error is [23]:

$$\tilde{M}_1 = \hat{M}_1 - M; \quad \tilde{C}_1 = \hat{C}_1 - C; \quad \tilde{G}_1 = \hat{G}_1 - G. \quad (9)$$

In addition to these, the estimation of second parameter $\hat{\pi}_2$ and the estimation of uncertainty bound $\hat{\rho}$ are defined. Considering $\hat{\pi}_2$ and $\hat{\rho}$, a new parameter error vector $\tilde{\theta}$ is defined as:

$$\tilde{\theta} = \hat{\pi}_2 - \hat{\rho}. \quad (10)$$

The unstructured model uncertainty and disturbances at the joints d are not constant but are bounded as:

$$\|d\| < \rho_{d1}. \quad (11)$$

Since $\rho_{d1} \in \mathbb{R}$ is assumed to be unknown, ρ_{d1} should be estimated with the estimation law to control the system properly. $\hat{\rho}_{d1}$ shows the estimate of ρ_{d1} and $\tilde{\rho}_{d1}$ is the estimation error. $\tilde{\rho}_{d1}$ is defined based on [11] as:

$$\tilde{\rho}_{d1} = \rho_{d1} - \hat{\rho}_{d1}. \tag{12}$$

In order to define a new controller, the following theorem is given.

Theorem 1 *Let $\varepsilon_d > 0$. Considering the control law defined in Eq. (6), the control inputs $\hat{\pi}_1$, u_1 , u_2 , and u_d are defined as:*

$$u_d = \begin{cases} \frac{\sigma}{\|\sigma\|} \hat{\rho}_d & \text{if } \|\sigma\| > \varepsilon_d \\ \frac{\sigma}{\varepsilon_d} \hat{\rho}_d & \text{if } \|\sigma\| \leq \varepsilon_d \end{cases}; \quad \dot{\hat{\pi}}_1 = \Gamma Y^T \sigma; \quad u_1 = \hat{\pi}_2; \quad u_2 = -\hat{\rho}, \tag{13}$$

where $\hat{\pi}_1$ and $\hat{\pi}_2$ are the estimation of the structured parameters and $\hat{\rho}$ is the estimation of the uncertainty bound of the unknown structured parameters. The dynamic compensators for the unknown structured parameters $\hat{\pi}_2$ and $\hat{\rho}$ are defined as follows:

$$\hat{\pi}_{2i} = (\beta_i^2 / \alpha_i) \text{Sin}(2\alpha \int Y^T \sigma dt)_i; \quad \hat{\rho}_i = \lambda_i \text{Cos}(\alpha \int Y^T \sigma dt)_i. \tag{14}$$

Uncertainty bound estimation laws for the unknown unstructured parameters are defined as:

$$\dot{\hat{\rho}}_{d1} = b_1 \|\sigma\|; \quad \hat{\rho}_{d2} = \frac{\psi^2}{\gamma} (e^{-\gamma \int \|\sigma\| dt} - e^{-2\gamma \int \|\sigma\| dt}); \quad \hat{\rho}_d = \hat{\rho}_{d1} + \hat{\rho}_{d2}, \tag{15}$$

where $b_1 \in \mathbb{R}^+$ and $\psi, \beta, \alpha, \lambda$, and $\gamma \in \mathbb{R}$ are the adaptation gains. If the control inputs $\hat{\pi}_1$, u_1 , u_2 , and u_d are substituted into the control law of Eq. (6) for controlling the robot manipulators, then the tracking errors $\dot{\tilde{q}}$ and \tilde{q} will converge to 0.

Proof In order to prove the theorem, a Lyapunov function is defined as:

$$V(\sigma, \tilde{q}, \phi, \tilde{\theta}, \tilde{\rho}_{d1}) = \frac{1}{2} \sigma^T M(q) \sigma + \frac{1}{2} \tilde{q}^T B \tilde{q} + \frac{1}{2} \tilde{\pi}_1^T \Gamma^{-1} \tilde{\pi}_1 + \frac{1}{2} \tilde{\theta}^T \tilde{\theta} + \frac{1}{2b_1} \tilde{\rho}_{d1}^2 + \frac{1}{2} \phi^2 \tilde{\rho}_{d2}^2 \geq 0, \tag{16}$$

where φ is a time-dependent function and changes with time. The time derivative of V along the system in Eq. (7) is:

$$\dot{V} = \sigma^T M(q) \dot{\sigma} + \frac{1}{2} \sigma^T \dot{M}(q) \sigma + \tilde{q}^T B \dot{\tilde{q}} + \tilde{\theta}^T \dot{\tilde{\theta}} + \tilde{\pi}_1^T \Gamma^{-1} \dot{\tilde{\pi}}_1 + \tilde{\rho}_{d1} b_1^{-1} \dot{\tilde{\rho}}_{d1} + \hat{\rho}_{d2} \phi \dot{\phi} \tilde{\rho}_{d2} + \hat{\rho}_{d2} \phi^2 \dot{\tilde{\rho}}_{d2}. \tag{17}$$

Substituting Eq. (7) into Eq. (17), the result is:

$$\dot{V} = \sigma^T [\frac{1}{2} \dot{M}(q) - C(q, \dot{q})] \sigma - \sigma^T K \sigma + \tilde{q}^T B \dot{\tilde{q}} - \sigma^T Y (u_1 + u_2) + \tilde{\pi}_1^T [\Gamma^{-1} \dot{\tilde{\pi}}_1 - Y^T \sigma] - \sigma^T u_d - (\rho_{d1} - \hat{\rho}_{d1}) b_1^{-1} \dot{\tilde{\rho}}_{d1} + \sigma^T d + \tilde{\theta}^T \dot{\tilde{\theta}} + \hat{\rho}_{d2} \phi \dot{\phi} \tilde{\rho}_{d2} + \hat{\rho}_{d2} \phi^2 \dot{\tilde{\rho}}_{d2}. \tag{18}$$

Note that $\dot{\tilde{\rho}}_{d1} = -\dot{\hat{\rho}}_{d1}$ since ρ_{d1} is a constant. The adaptation law is chosen such that:

$$Y^T \sigma - \Gamma^{-1} \dot{\tilde{\pi}}_1 = 0. \tag{19}$$

That is [23]:

$$\dot{\hat{\pi}}_1 = \Gamma Y^T \sigma. \tag{20}$$

Note that $\dot{\hat{\pi}}_1 = \dot{\pi}_1$ since π is a constant. Next, the term in Eq. (18) will be 0 such that:

$$\tilde{\pi}^T [Y^T \sigma - \Gamma^{-1} \dot{\hat{\pi}}_1] = 0. \tag{21}$$

Taking $B = 2\Lambda K$, using the property $\sigma^T [M(q) - 2C(q, \dot{q})] \sigma = 0 \forall \sigma \in R^n$ [2,23], and substituting $\dot{\hat{\rho}}_{d1} = b_1 \|\sigma\|$ from Eq. (15) into Eq. (18), Eq. (18) becomes:

$$\begin{aligned} \dot{V} = & -\dot{\tilde{q}}^T K \dot{\tilde{q}} - \tilde{q}^T \Lambda K \Lambda \tilde{q} - \sigma^T Y (u_1 + u_2) - \sigma^T u_d - \|\sigma\| \rho_{d1} \\ & + \|\sigma\| \dot{\hat{\rho}}_{d1} + \sigma^T d + \tilde{\theta}^T \dot{\tilde{\theta}} + \hat{\rho}_{d2} \phi \dot{\phi} \hat{\rho}_{d2} + \hat{\rho}_{d2} \phi^2 \dot{\hat{\rho}}_{d2} \end{aligned} \tag{22}$$

□

2.1. Adaptive compensators for the unknown structured parameters

As seen from Eq. (22), there are relationships between the control inputs u_1 , u_2 , and u_d and the time-dependent function $\tilde{\theta}^T \dot{\tilde{\theta}}$. The time-dependent function $\tilde{\theta}^T \dot{\tilde{\theta}}$ is defined as:

$$\tilde{\theta}^T \dot{\tilde{\theta}} = [(2\beta^2/\alpha) \sin(\alpha \int (Y^T \sigma dt)) - \lambda]^2 / (2\beta)^2. \tag{23}$$

Next, $\tilde{\theta}^T \dot{\tilde{\theta}}$ is obtained as:

$$\begin{aligned} \tilde{\theta}^T \dot{\tilde{\theta}} &= [(2\beta^2/\alpha) \sin(\alpha \int (Y^T \sigma dt)) - \lambda] \cos(\alpha \int (Y^T \sigma dt)) (Y^T \sigma) \\ &= [(2\beta^2/\alpha) \sin(\alpha \int (Y^T \sigma dt)) \cos(\alpha \int (Y^T \sigma dt)) - \lambda \cos(\alpha \int (Y^T \sigma dt))] (Y^T \sigma) \\ &= \sigma^T Y (\pi_2 - \hat{\rho}) \end{aligned} \tag{24}$$

The control parameters are defined in Eq. (13) such that $u_1 = \hat{\pi}_2$ and $u_2 = -\hat{\rho}$. Substituting the control parameters $u_1 = \hat{\pi}_2$ and $u_2 = -\hat{\rho}$ from Eq. (13) and Eq. (24) into Eq. (22), the following equation is obtained:

$$\begin{aligned} \dot{V} = & -\dot{\tilde{q}}^T K \dot{\tilde{q}} - \tilde{q}^T \Lambda K \Lambda \tilde{q} - \sigma^T Y (\hat{\pi}_2 - \hat{\rho}) + \sigma^T Y (\hat{\pi}_2 - \hat{\rho}) + \sigma^T u_d - \|\sigma\| \rho_{d1} + \sigma^T d \\ & + \|\sigma\| \dot{\hat{\rho}}_{d1} + \hat{\rho}_{d2} \phi \dot{\phi} \hat{\rho}_{d2} + \hat{\rho}_{d2} \phi^2 \dot{\hat{\rho}}_{d2} \end{aligned} \tag{25}$$

As seen from Eq. (25), the third and fourth terms are canceled out by each other and then Eq. (25) is arranged as:

$$\dot{V} = -\dot{\tilde{q}}^T K \dot{\tilde{q}} - \tilde{q}^T \Lambda K \Lambda \tilde{q} - \|\sigma\| \rho_{d1} + \|\sigma\| \dot{\hat{\rho}}_{d1} + \sigma^T d - \sigma^T u_d + \hat{\rho}_{d2} \phi \dot{\phi} \hat{\rho}_{d2} + \hat{\rho}_{d2} \phi^2 \dot{\hat{\rho}}_{d2}. \tag{26}$$

2.2. Adaptive compensators for the unknown unstructured parameters and disturbances

In order to design uncertainty bound estimation functions for the unknown unstructured parameters, the function φ is defined as:

$$\phi = \frac{e^{\gamma \int \|\sigma\| dt}}{\psi}. \tag{27}$$

There is no certain rule for the determination of φ for the control input u_d that satisfies $\dot{V} \leq 0$. System state parameters and mathematical insight are used to search for the appropriate function of φ to prove the theorem.

From Eq. (15), $\hat{\rho}_{d2}$ and $\dot{\hat{\rho}}_{d2}$ are written as:

$$\hat{\rho}_{d2} = \frac{\psi^2}{\gamma}(e^{-\gamma \int \|\sigma\| dt} - e^{-2\gamma \int \|\sigma\| dt}); \quad \dot{\hat{\rho}}_{d2} = \frac{\psi^2}{\gamma}(-e^{-\gamma \int \|\sigma\| dt} + 2e^{-2\gamma \int \|\sigma\| dt})(\gamma \|\sigma\|). \quad (28)$$

If $\hat{\rho}_{d2}$, $\dot{\hat{\rho}}_{d2}$, ϕ , and $\dot{\phi}$ are substituted into Eq. (26), the term $\hat{\rho}_{d2}^2 \phi \dot{\phi} + \hat{\rho}_{d2} \dot{\hat{\rho}}_{d2} \phi^2$ will be written as:

$$\begin{aligned} \hat{\rho}_{d2}^2 \phi \dot{\phi} + \hat{\rho}_{d2} \dot{\hat{\rho}}_{d2} \phi^2 &= \frac{\psi^4}{\gamma^2}(e^{-\gamma \int \|\sigma\| dt} - e^{-2\gamma \int \|\sigma\| dt})^2 \psi^{-2} e^{2\gamma \int \|\sigma\| dt} (\gamma \|\sigma\|) \\ &\quad + \frac{\psi^4}{\gamma^2}(e^{-\gamma \int \|\sigma\| dt} - e^{-2\gamma \int \|\sigma\| dt}) \psi^{-2} e^{2\gamma \int \|\sigma\| dt} (-e^{-\gamma \int \|\sigma\| dt} + 2e^{-2\gamma \int \|\sigma\| dt}) (\gamma \|\sigma\|) \\ &= \frac{\psi^4}{\gamma^2}(e^{-2\gamma \int \|\sigma\| dt} - 2e^{-3\gamma \int \|\sigma\| dt} + e^{-4\gamma \int \|\sigma\| dt} - e^{-2\gamma \int \|\sigma\| dt} \\ &\quad + 3e^{-3\gamma \int \|\sigma\| dt} - 2e^{-4\gamma \int \|\sigma\| dt}) \psi^{-2} e^{2\gamma \int \|\sigma\| dt} (\gamma \|\sigma\|) \\ &= \frac{\psi^2}{\gamma}(e^{-\gamma \int \|\sigma\| dt} - e^{-2\gamma \int \|\sigma\| dt}) \|\sigma\| \end{aligned} \quad (29)$$

Next, Eq. (26) is obtained as:

$$\begin{aligned} \dot{V} &= -\dot{\tilde{q}}^T K \dot{\tilde{q}} - \tilde{q}^T \Lambda K \Lambda \tilde{q} - \|\sigma\| \rho_{d1} + \sigma^T d + \|\sigma\| \hat{\rho}_{d1} - \sigma^T u_d + \frac{\psi^2}{\gamma}(e^{-\gamma \int \|\sigma\| dt} - e^{-2\gamma \int \|\sigma\| dt}) \|\sigma\| \\ &\leq -\dot{\tilde{q}}^T K \dot{\tilde{q}} - \tilde{q}^T \Lambda K \Lambda \tilde{q} + \|\sigma\| (\|d\| - \rho_{d1}) + \|\sigma\| \hat{\rho}_{d1} - \sigma^T u_d + \|\sigma\| \hat{\rho}_{d2} \\ &\leq -\dot{\tilde{q}}^T K \dot{\tilde{q}} - \tilde{q}^T \Lambda K \Lambda \tilde{q} + \|\sigma\| (\hat{\rho}_{d1} + \hat{\rho}_{d2}) - \sigma^T u_d \\ &\leq -\dot{\tilde{q}}^T K \dot{\tilde{q}} - \tilde{q}^T \Lambda K \Lambda \tilde{q} + \|\sigma\| \hat{\rho}_d - \sigma^T u_d \end{aligned} \quad (30)$$

where $\hat{\rho}_{d2} = \frac{\psi^2}{\gamma}(e^{-\gamma \int \|\sigma\| dt} - e^{-2\gamma \int \|\sigma\| dt})$ and $\hat{\rho}_d = \hat{\rho}_{d1} + \hat{\rho}_{d2}$. Two cases are considered for proof of the theorem.

Case 1. $\|\sigma\| \geq \varepsilon_d$.

For Case 1, the control input is defined as $u_d = \frac{\sigma}{\|\sigma\|} \hat{\rho}_d$. Next, Eq. (30) is obtained as:

$$\begin{aligned} \dot{V} &= -\dot{\tilde{q}}^T K \dot{\tilde{q}} - \tilde{q}^T \Lambda K \Lambda \tilde{q} + \|\sigma\| \hat{\rho}_d - \frac{\sigma^T \sigma \hat{\rho}_d}{\|\sigma\|} \\ &\leq -\dot{\tilde{q}}^T K \dot{\tilde{q}} - \tilde{q}^T \Lambda K \Lambda \tilde{q} + \|\sigma\| (\hat{\rho}_d - \hat{\rho}_d) \leq 0 \end{aligned} \quad (31)$$

Since K and Λ are the positive definite matrices, $\dot{V} \leq 0$ and the system is stable. Eq. (16) shows that V is a positive continuous function and V tends to be constant as $t \rightarrow \infty$, and therefore V remains bounded. Thus, $\dot{\tilde{q}}$ and \tilde{q} are bounded; that is, $\dot{\tilde{q}}$ and \tilde{q} converge to 0 and this implies that σ is bounded and converges to 0. As a result, $\int Y^T \sigma dt$ is bounded and converges to a constant. The trigonometric functions are bounded, implying that $\hat{\pi}_1$, $\hat{\pi}_2$, $\hat{\rho}$, and $\hat{\rho}_d$ are bounded.

Case 2. $\|\sigma\| \leq \varepsilon_d$.

For Case 2, the control input is defined as $u_d = \frac{\sigma}{\varepsilon_d} \hat{\rho}_d$. Next, Eq. (30) is obtained as:

$$\begin{aligned} \dot{V} &\leq -\dot{\tilde{q}}^T K \dot{\tilde{q}} - \tilde{q}^T \Lambda K \Lambda \tilde{q} + \|\sigma\| \hat{\rho}_d - \sigma^T \frac{\sigma}{\varepsilon_d} \hat{\rho}_d \\ &\leq -\dot{\tilde{q}}^T K \dot{\tilde{q}} - \tilde{q}^T \Lambda K \Lambda \tilde{q} + \|\sigma\| (\hat{\rho}_d - \frac{\|\sigma\|}{\varepsilon_d} \hat{\rho}_d) \end{aligned} \quad (32)$$

This last term achieves a maximum value of $\varepsilon \hat{\rho}_d / 4$ when $\|\sigma\| = \varepsilon / 2$. We have:

$$\dot{V} \leq -x^T Q x + \varepsilon_d \frac{\hat{\rho}_d}{4} \leq 0, \tag{33}$$

where $x^T = [\dot{\tilde{q}}^T, \tilde{q}^T]$ and $Q = \text{diag}[\Lambda K \Lambda, K]$, provided that:

$$x^T Q x \geq \varepsilon_d \frac{\hat{\rho}_d}{4}, \tag{34}$$

using the relationship:

$$\delta_{\min} Q \leq x^T Q x \leq \delta_{\max} Q, \tag{35}$$

where $\delta_{\min}(Q)$ and $\delta_{\max}(Q)$ denote the minimum and maximum eigenvalues of Q , respectively. It can be obtained that $\dot{V} \leq 0$ if:

$$\delta_{\min} Q \|x\|^2 \geq \varepsilon_d \frac{\hat{\rho}_d}{4}. \tag{36}$$

It is shown that $\dot{V} \leq 0$ for $\|x\| > w$, where:

$$\|x\| \geq \sqrt{\frac{\varepsilon_d \hat{\rho}_d}{4 \delta_{\min}(Q)}} = w. \tag{37}$$

$$\tau = Y(q, \dot{q}, \ddot{q}_r, \ddot{q}_r)[\hat{\pi}_1 + (\beta^2/\alpha) \text{Sin}(2\alpha \int Y^T \sigma dt) - \lambda \text{Cos}(\alpha \int Y^T \sigma dt)] + u_d + K \sigma. \tag{38}$$

The resulting block diagram is given in Figure 1.

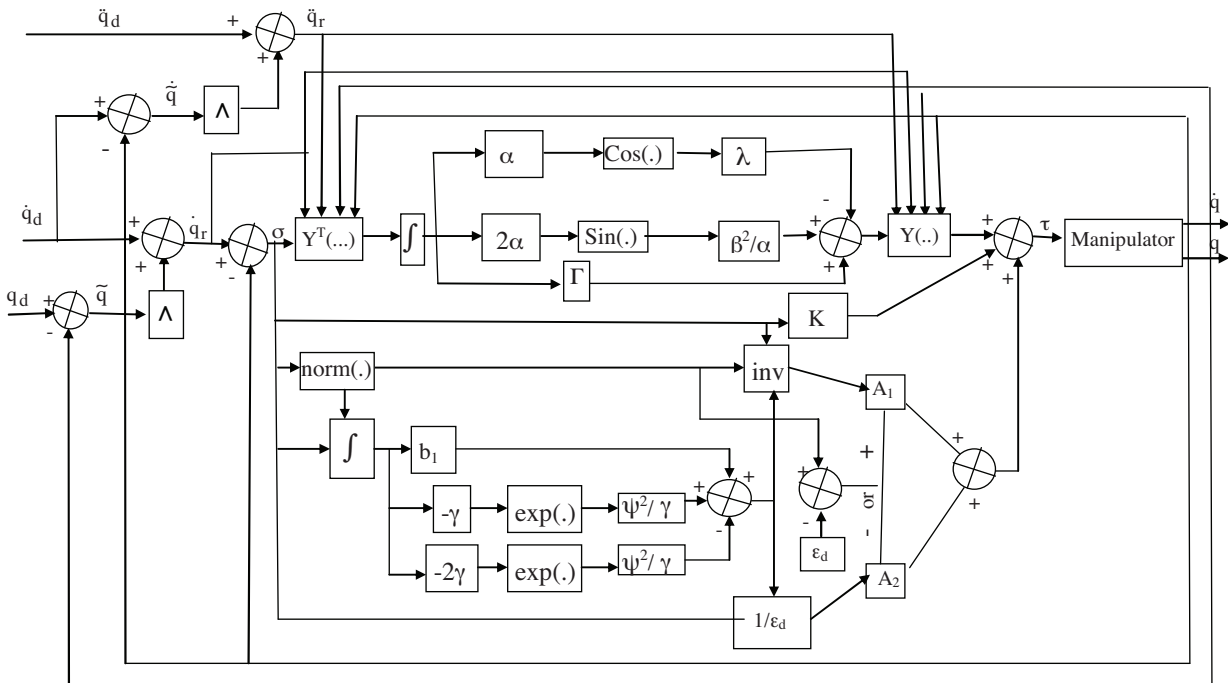

Figure 1. Block diagram of the adaptive-robust control law in Eq. (38).

Let S_w denote the smallest level set of V containing $B(\delta)$, the ball of the radius w , and let B_r denote the smallest ball containing S_δ . Next, all of the solutions of the closed system are of uniform ultimate boundedness with respect to B_r . The situation is shown in Figure 2. All trajectories will eventually enter the ball B_r ; in fact, all trajectories will reach the boundary of S_δ since \dot{V} is defined as negative outside of S_δ . Note that the radius of the ultimate boundedness set, and hence the magnitude of the state tracking error, are proportional to the product of uncertainty bound and the constant ε_d [24].

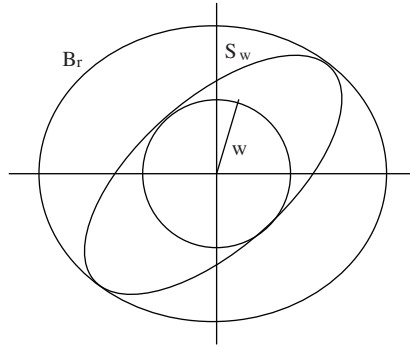

Figure 2. The uniform ultimate boundedness set. Since \dot{V} is negative outside the ball B_r , all trajectories will eventually enter the level set S_δ , the smallest level set of V containing B_δ . The system is of uniform ultimate boundedness with respect to B_r , the smallest ball containing S_w [24].

3. Simulation results

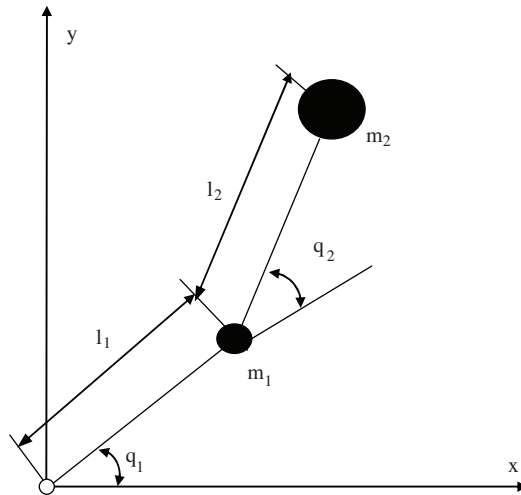

Figure 3. Two-link planar robot [25].

The matrix $M(q)$, $C(q, \dot{q})$, and the vector $G(q)$ in Eq. (1) are given by [25]:

$$M(q) = \begin{bmatrix} (m_1 + m_2)l_1^2 + m_2l_2^2 + 2m_2l_1l_2 \cos q_2 & m_2l_2^2 + m_2l_1l_2 \cos q_2 \\ m_2l_2^2 + m_2l_1l_2 \cos q_2 & m_2l_2^2 \end{bmatrix};$$

$$C = \begin{bmatrix} -m_2l_1l_2(2\dot{q}_2) \sin q_2 & -m_2l_1l_2\dot{q}_2 \sin q_2 \\ m_2l_1l_2\dot{q}_2 \sin q_2 & 0 \end{bmatrix};$$

$$G = \begin{bmatrix} (m_1 + m_2)g_c l_1 \cos q_1 + m_2 g_c l_2 \cos(q_1 + q_2) \\ m_2 g_c l_2 \cos(q_1 + q_2) \end{bmatrix}. \quad (39)$$

With this parameterization, the dynamic model in Eq. (2) can be written as:

$$\tau = Y(q, \dot{q}, \ddot{q})\pi = \begin{bmatrix} y_{11} & y_{12} & y_{13} & y_{14} & y_{15} & y_{16} \\ y_{21} & y_{22} & y_{23} & y_{24} & y_{25} & y_{26} \end{bmatrix} \pi, \quad (40)$$

where $\pi = [\pi_1 \ \pi_2 \ \pi_3 \ \pi_4 \ \pi_5 \ \pi_6]^T$. The robot link parameters are:

$$\begin{aligned} \pi_1 &= (m_1 + m_2)l_1^2, & \pi_2 &= m_2 l_2^2, & \pi_3 &= m_2 l_1 l_2, \\ \pi_4 &= m_1 l_1, & \pi_5 &= m_2 l_1, & \pi_6 &= m_2 l_2. \end{aligned} \quad (41)$$

The components y_{ij} of $Y(q, \dot{q}, \ddot{q})$ in Eq. (40) are given as:

$$\begin{aligned} y_{11} &= \ddot{q}_1; & y_{12} &= \ddot{q}_1 + \ddot{q}_2; & y_{13} &= \cos(q_2)(2\ddot{q}_1 + \ddot{q}_2) - \sin(q_2)(\dot{q}_2^2 + 2\dot{q}_1\dot{q}_2); \\ y_{14} &= g_c \cos(q_1); & y_{15} &= g_c \cos(q_1); & y_{16} &= g_c \cos(q_1 + q_2); \\ y_{21} &= 0; & y_{22} &= \ddot{q}_1 + \ddot{q}_2; & y_{23} &= \cos(q_2)\ddot{q}_1 + \sin(q_2)(\dot{q}_1^2); \\ y_{24} &= 0; & y_{25} &= 0; & y_{26} &= g_c \cos(q_1 + q_2). \end{aligned} \quad (42)$$

$Y(q, \dot{q}, \dot{q}_r, \ddot{q}_r)$ in Eq. (2) has the following components:

$$\begin{aligned} y_{11} &= \ddot{q}_{r1}; & y_{12} &= \ddot{q}_{r1} + \ddot{q}_{r2}; \\ y_{13} &= \cos(q_2)(2\ddot{q}_{r1} + \ddot{q}_{r2}) - \sin(q_2)(\dot{q}_1\dot{q}_{r2} + \dot{q}_1\dot{q}_{r2} + \dot{q}_2\dot{q}_{r2}); \\ y_{14} &= g_c \cos(q_1); & y_{15} &= g_c \cos(q_1); & y_{16} &= g_c \cos(q_1 + q_2); \\ y_{21} &= 0; & y_{22} &= \ddot{q}_{r1} + \ddot{q}_{r2}; & y_{23} &= \cos(q_2)\ddot{q}_{r1} + \sin(q_2)(\dot{q}_1\dot{q}_{r1}); \\ y_{24} &= 0; & y_{25} &= 0; & y_{26} &= g_c \cos(q_1 + q_2). \end{aligned} \quad (43)$$

In order to investigate the performance of the proposed control law, computer simulations are carried out for 4 cases, which are given below.

Case 1. $\beta = 0$, $\lambda = 0$, and $u_d = 0$. In this case, the pure adaptive control law [23] is obtained and the control input in Eq. (38) is obtained as:

$$\tau = Y(q, \dot{q}, \dot{q}_r, \ddot{q}_r)\hat{\pi}_1 + K\sigma. \quad (44)$$

Case 2. $\beta = 0$ and $\lambda = 0$. A pure adaptive control law with an unstructured model uncertainty compensator is obtained. In this case, the control input in Eq. (38) is obtained as:

$$\tau = Y(q, \dot{q}, \dot{q}_r, \ddot{q}_r)\hat{\pi}_1 + u_d + K\sigma. \quad (45)$$

Case 3. $u_d = 0$. In this case, an unstructured model uncertainty compensator u_d is not considered. Only the adaptive control law with structured uncertainty compensators is considered and the control input in Eq. (38) is obtained as:

$$\tau = Y(q, \dot{q}, \dot{q}_r, \ddot{q}_r)[\hat{\pi}_1 + (\beta^2/\alpha_i)\text{Sin}(2\alpha \int Y^T \sigma dt) - \lambda \text{Cos}(\alpha \int Y^T \sigma dt)] + K\sigma. \quad (46)$$

Case 4. The adaptive control law in Eq. (38), with compensators for structured and unstructured dynamics, is used.

For computer simulation, the desired trajectory for both joints is defined as $q_1 = q_2 = 2\cos(t)-2$. The simulations have been done under robot parameters such as $l_1 = l_2 = 1$, $m_1 = 3$, $m_2 = 15$. In order to investigate the performance of the proposed adaptive-robust controller, each control law with the same control parameters, such as $K = \text{diag}(25 \ 25)$ and $\Lambda = \text{diag}(25 \ 25)$, is applied to the same model system using the same trajectory. The disturbance torque is defined as $d = 20\sin(10t)$ at each joint. The control parameters Λ and K are chosen to be identical, while the control parameters Γ , α , β , b_1 , λ , ψ , and γ are changed. The obtained results are given in Figures 4–6.

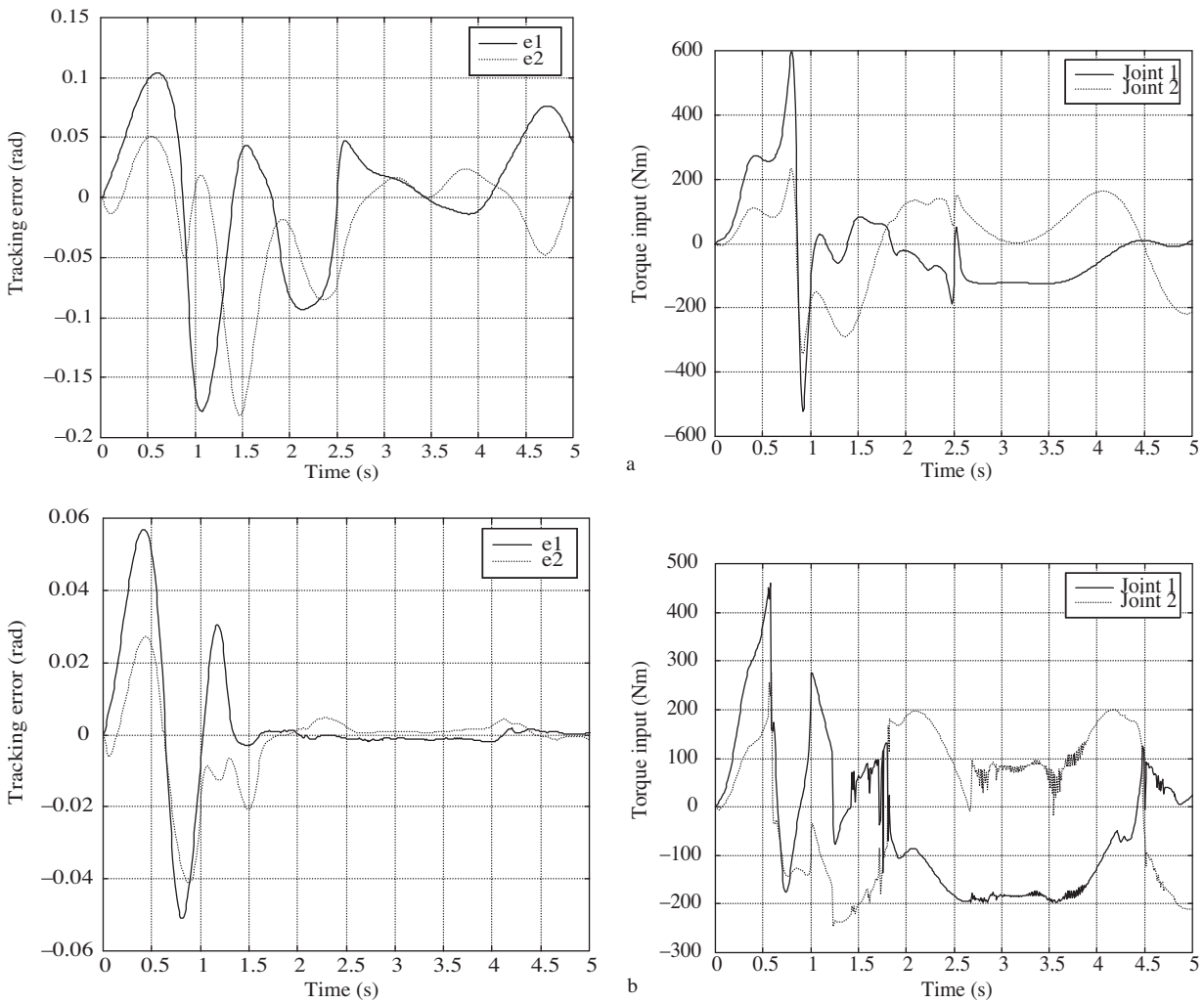

Figure 4. a) Response using the adaptive control law in Eq. (44) [23] for Case 1, for $\Lambda = \text{diag}([25 \ 25])$, $K = \text{diag}([25 \ 25])$ with a disturbance torque $d = 20\sin(10t)$ at each joint, and b) response using the adaptive control law in Eq. (45) for Case 2, for $\Lambda = \text{diag}([25 \ 25])$, $K = \text{diag}([25 \ 25])$, $\Gamma = 1$, $b_1 = 20$, $\psi = 12$, and $\gamma = 0.2$ with a disturbance torque $d = 20\sin(10t)$ at each joint.

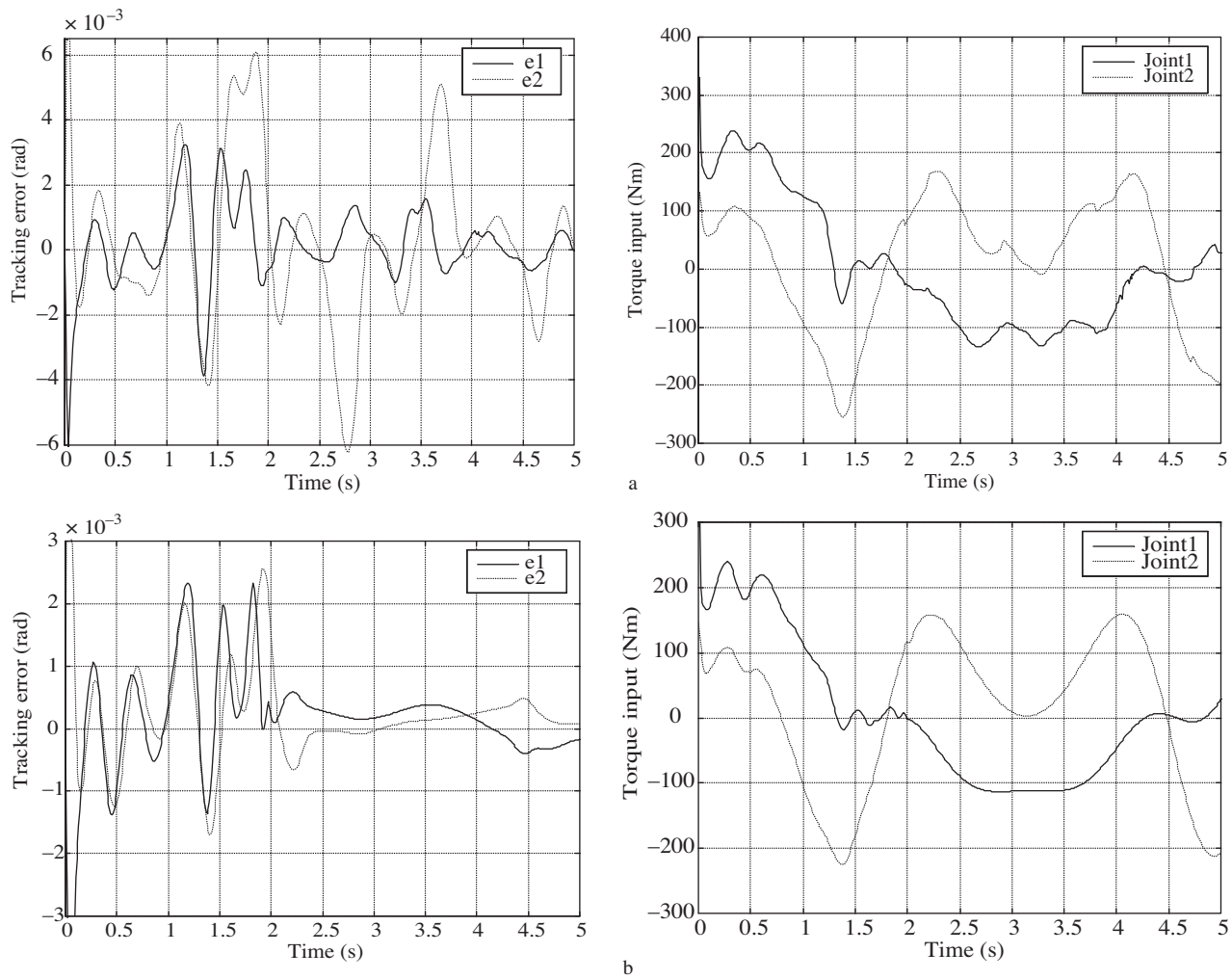

Figure 5. a) Response using the adaptive-robust control law in Eq. (38) for Case 4, for $\Lambda = \text{diag}([25 \ 25])$, $K = \text{diag}([25 \ 25])$, $\Gamma = 1$, $\alpha = 12$, $\beta = 18$, $b_1 = 15$, $\lambda = -15$, $\psi = 12$, and $\gamma = 2$ with a disturbance torque $d = 20\sin(10t)$ at each joint, and b) response using the adaptive control law in Eq. (38) for Case 4, for $\Lambda = \text{diag}([25 \ 25])$, $K = \text{diag}([25 \ 25])$, $\Gamma = 1$, $\alpha = 12$, $\beta = 18$, $b_1 = 15$, $\lambda = -15$, $\psi = 12$, and $\gamma = 2$ without a disturbance torque $d = 0$ at each joint.

As shown in Figure 4, the tracking performance is poor in the case where the pure adaptive controller in Eq. (44) is used. The steady state response of the pure adaptive controller is improved and the disturbance is rejected with the additional control input u_d for Case 2. As shown in Figure 5, the transient and steady state performance of the system is improved and the disturbance torque is rejected by the proposed adapted control law in Eq. (38). Figure 6 shows the tracking performance of the control law in Eq. (46) for Case 3 with and without the disturbance torques in the joints. The pure adaptive-robust controller in Eq. (46) is robust to the structured unknown parameters but showed poor robustness to the unstructured unknown parameters and external disturbances. The proposed control law in Eq. (38) also seems to be more attractive where the robustness to disturbance and the unstructured dynamics are concerned and the unstructured parametric uncertainty is large. For explanations, estimation of the parameters and uncertainty bound parameters are given in Figures 7–12.

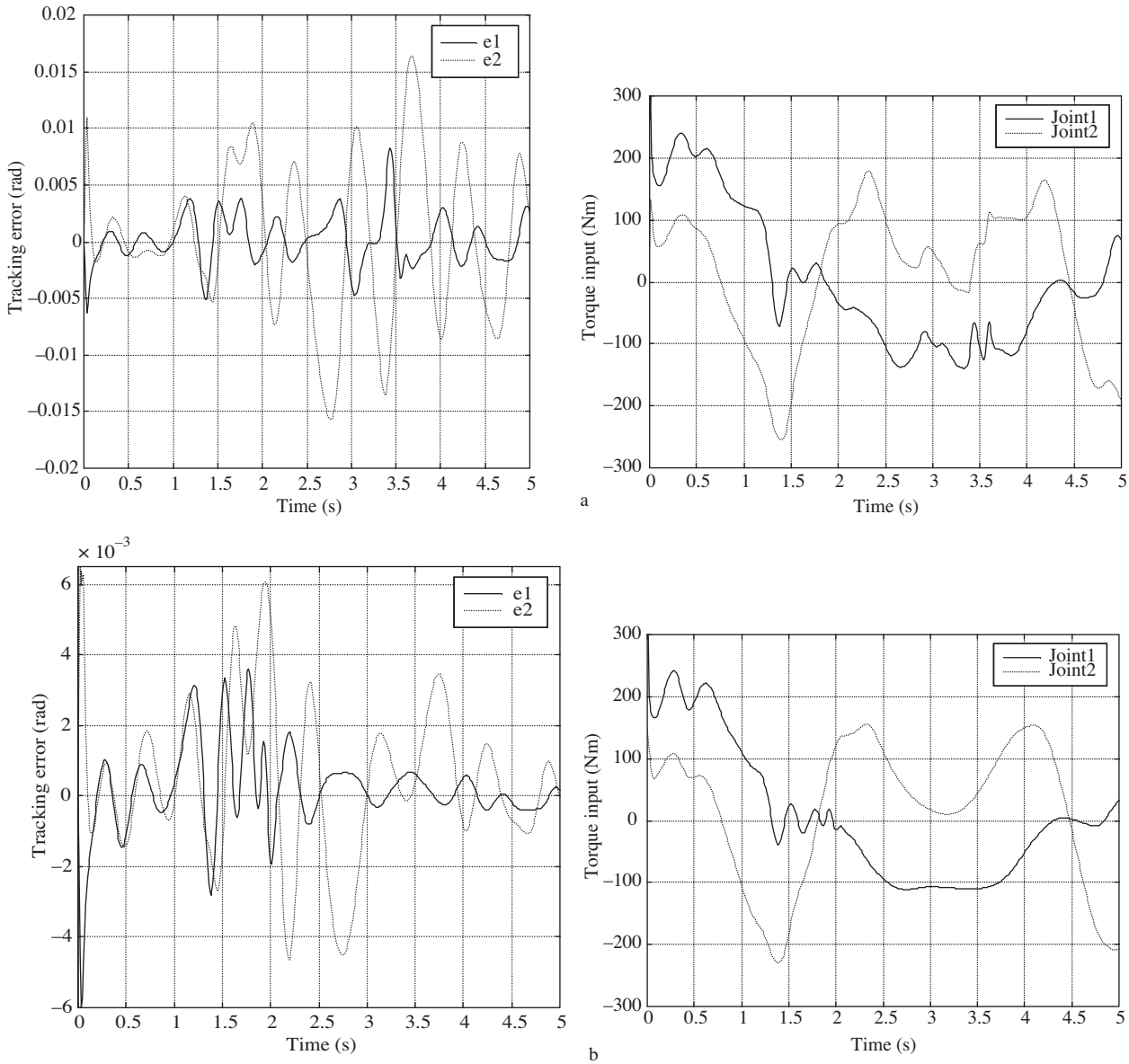

Figure 6. a) Response using the adaptive control law in Eq. (46) for Case 3, for $\Lambda = \text{diag}([25 \ 25])$, $K = \text{diag}([25 \ 25])$, $\Gamma = 1$, $\alpha = 12$, $\beta = 18$, $b_1 = 0$, $\lambda = -15$, $\psi = 0$, and $\gamma = 0$ with a disturbance torque $d = 20\sin(10t)$ at each joint, and b) response using the adaptive control law in Eq. (46) for Case 3, $\Lambda = \text{diag}([25 \ 25])$, $K = \text{diag}([25 \ 25])$, $\Gamma = 1$, $\alpha = 12$, $\beta = 18$, $b_1 = 0$, $\lambda = -15$, $\psi = 0$, and $\gamma = 0$ without a disturbance torque $d = 0$ at each joint.

Parameter estimation laws for unknown structured and unstructured parameters $\hat{\pi}_1$, $\hat{\pi}_2$, $\hat{\rho}$, and $\hat{\rho}_d$ are estimated with estimation laws in order to reduce the tracking error. As shown in Figures 7–12, the values of $\hat{\pi}_1$ for the structured parameter are large for the pure adaptive control law in Eq. (44). The values of $\hat{\pi}_1$ for the structured parameter are small and the value of $\hat{\rho}_d$ for the unstructured parameter is large for Case 2. The values of $\hat{\pi}_1$ are very small and $\hat{\pi}_2$, $\hat{\rho}$, and $\hat{\rho}_d$ are estimated properly for the proposed adaptive-robust control law in Eq. (38).

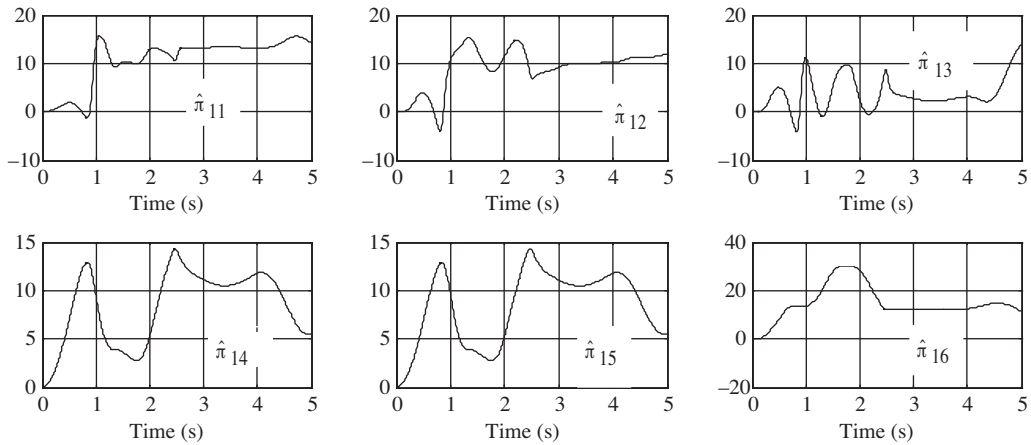

Figure 7. Estimation of the adaptive-robust control law in Eq. (44) [23] for Case 1, for $\Lambda = \text{diag}([25 \ 25])$, $K = \text{diag}([25 \ 25])$ with a disturbance torque $d = 20\sin(10t)$ at each joint.

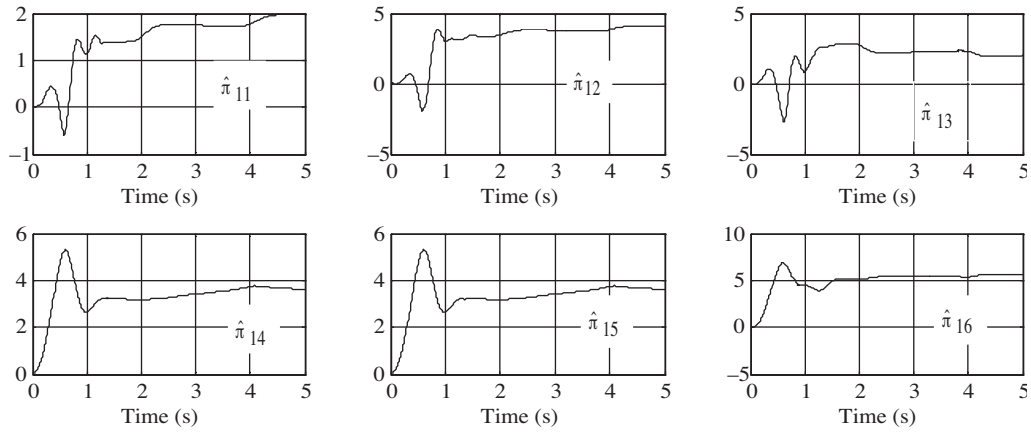

Figure 8. Estimation of $\hat{\pi}_1$ for the adaptive-robust control law in Eq. (45) for Case 2, for $\Lambda = \text{diag}([25 \ 25])$, $K = \text{diag}([25 \ 25])$, $\Gamma = 1$, $b_1 = 20$, $\psi = 12$, and $\gamma = 0.2$ with a disturbance torque $d=20\sin(10t)$ at each joint.

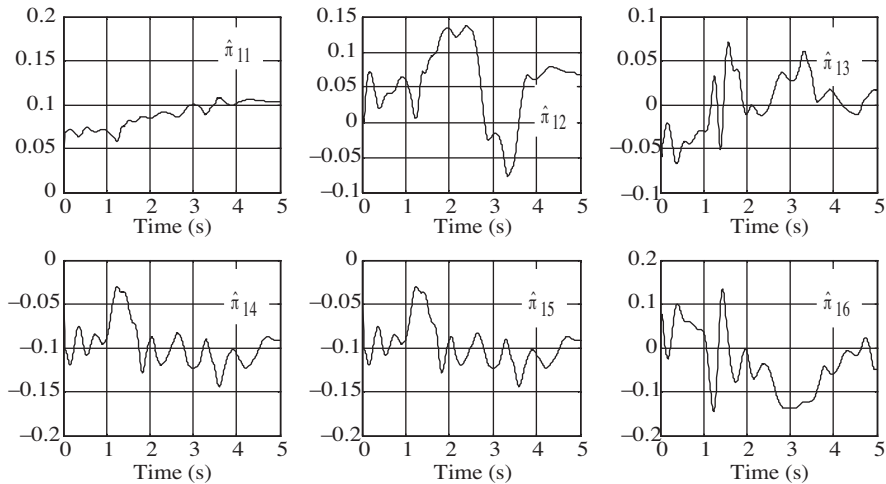

Figure 9. Estimation of $\hat{\pi}_1$ for the adaptive-robust control law in Eq. (38) for Case 4, for $\Lambda = \text{diag}([25 \ 25])$, $K = \text{diag}([25 \ 25])$, $\Gamma = 1$, $\alpha = 12$, $\beta = 18$, $b_1 = 15$, $\lambda = -15$, $\psi = 12$, and $\gamma = 2$ with a disturbance torque $d = 20\sin(10t)$ at each joint.

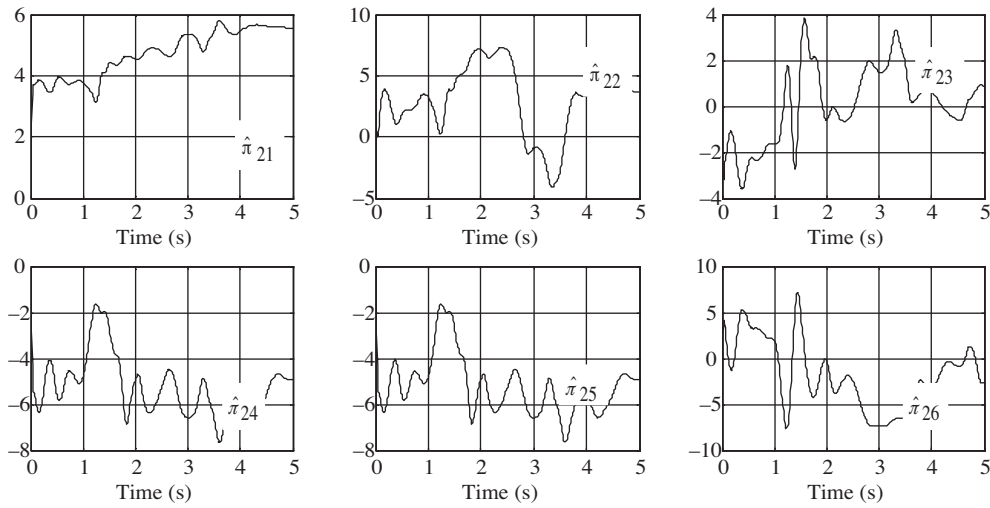

Figure 10. Estimation of $\hat{\pi}_2$ for the adaptive-robust control law in Eq. (38) for Case 4, for $\Lambda = \text{diag}([25 \ 25])$, $K = \text{diag}([25 \ 25])$, $\Gamma = 1$, $\alpha = 12$, $\beta = 18$, $b_1 = 15$, $\lambda = -15$, $\psi = 12$, and $\gamma = 2$ with a disturbance torque $d = 20\sin(10t)$ at each joint.

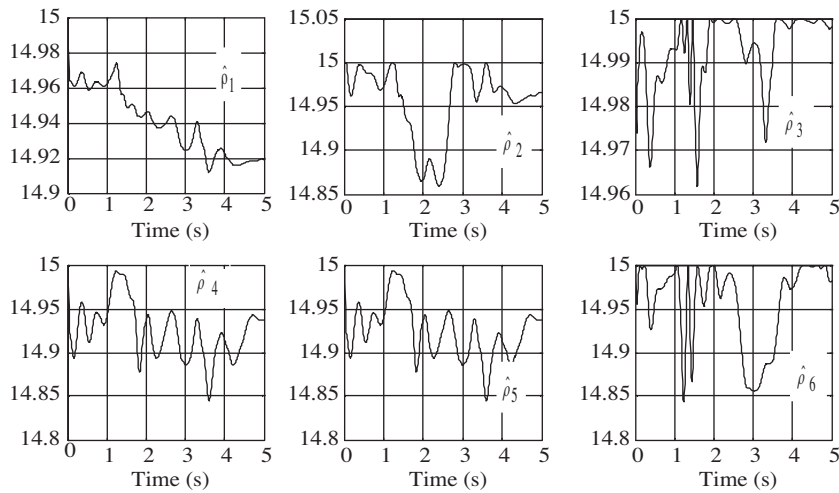

Figure 11. Estimation of $\hat{\rho}$ for the adaptive-robust control law in Eq. (38) for Case 4, for $\Lambda = \text{diag}([25 \ 25])$, $K = \text{diag}([25 \ 25])$, $\Gamma = 1$, $\alpha = 12$, $\beta = 18$, $b_1 = 15$, $\lambda = -15$, $\psi = 12$, and $\gamma = 2$ with a disturbance torque $d = 20\sin(10t)$ at each joint.

In order to investigate the performance of the proposed controller, another simulation is carried out with a different disturbance torque and sensor noise. The disturbance torque is defined as $d = 15\sin(10t)-12$ at each joint. It is assumed that the sensor cannot measure the position and velocity precisely and there is a difference between the actual and measured values of the position and velocity. The differences between the measured and actual values of the position and velocity are defined as $(0.002)\sin(10t)-0.001$ for each joint. The obtained result is given in Figure 13.

As shown in Figure 13, the proposed control law can compensate for different external disturbances and sensor noises.

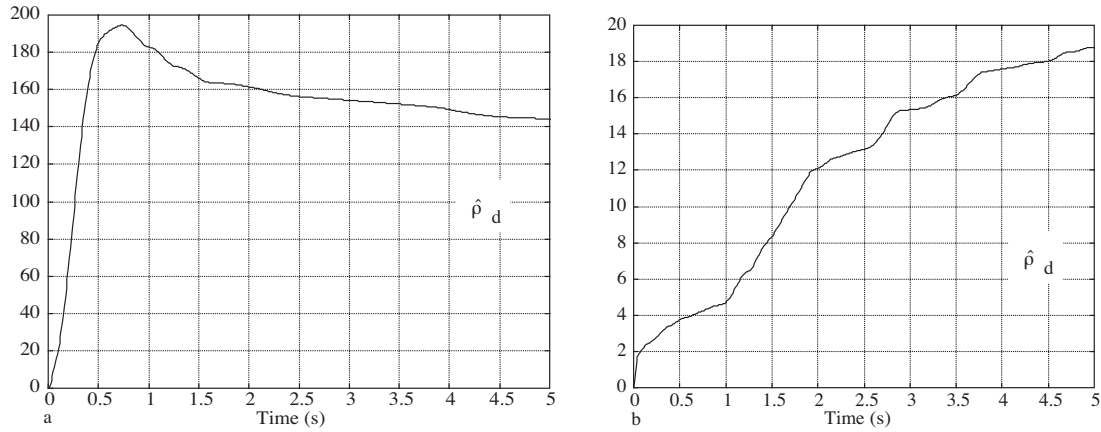

Figure 12. a) Estimation of $\hat{\rho}_d$ for the adaptive control law in Eq. (45) for Case 2, for $\Lambda = \text{diag}([25 \ 25])$, $K = \text{diag}([25 \ 25])$, $\Gamma = 1$, $b_1 = 20$, $\psi = 12$, and $\gamma = 0.2$ with a disturbance torque $d = 20\sin(10t)$ at each joint, and b) estimation of $\hat{\rho}_d$ for the adaptive-robust control law in Eq. (38) for Case 4, for $\Lambda = \text{diag}([25 \ 25])$, $K = \text{diag}([25 \ 25])$, $\Gamma = 1$, $\alpha = 12$, $\beta = 18$, $b_1 = 15$, $\lambda = -15$, $\psi = 12$, and $\gamma = 2$ with a disturbance torque $d = 20\sin(10t)$ at each joint.

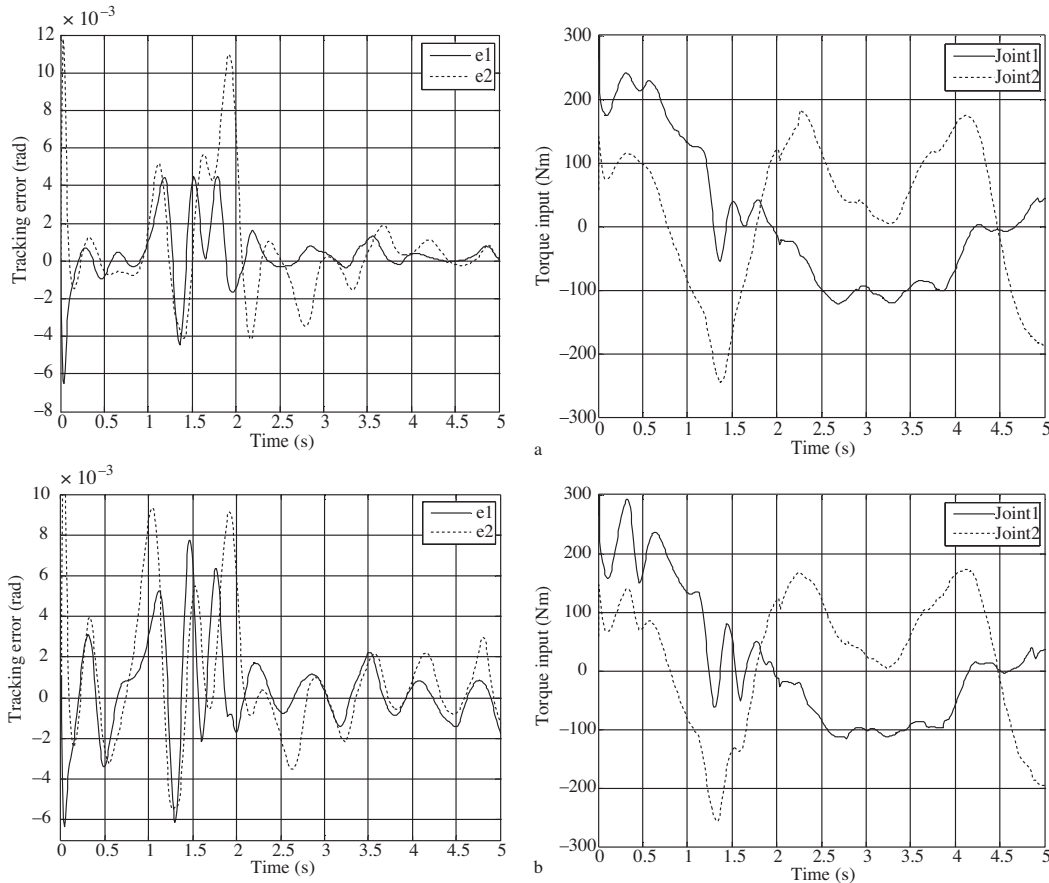

Figure 13. a) Response using the adaptive-robust control law in Eq. (38) for Case 4, for $\Lambda = \text{diag}([25 \ 25])$, $K = \text{diag}([25 \ 25])$, $\Gamma = 1$, $\alpha = 12$, $\beta = 18$, $b_1 = 15$, $\lambda = -15$, $\psi = 12$, and $\gamma = 2$ with a disturbance torque $d = 15\sin(10t)-12$ at each joint, and b) response using the adaptive control law in Eq. (38) for Case 4, for $\Lambda = \text{diag}([25 \ 25])$, $K = \text{diag}([25 \ 25])$, $\Gamma = 1$, $\alpha = 12$, $\beta = 18$, $b_1 = 15$, $\lambda = -15$, $\psi = 12$, and $\gamma = 2$ with a disturbance torque $d = 15\sin(10t)-12$ with a sensor noise $(0.002)\sin(10t)-0.001$ at each joint.

4. Conclusion

In this paper, a new adaptive-robust control approach for robot manipulators was developed in order to improve tracking performance in the presence of unknown structured and unstructured parameters such as joint friction and disturbances. The bounded disturbance and unstructured model were taken into account in a dynamic model. It was assumed that the structured and unstructured parameters are unknown and a priori knowledge is not required. In order to investigate the effect of the control parameters Γ , α , β , b_1 , λ , ψ , and γ on the tracking performance, the control parameters Λ and K were chosen to be identical, while the control parameters Γ , α , β , b_1 , λ , ψ , and γ were changed. A computer simulation was carried out under the same conditions with the same control parameters: $K = \text{diag}(25 \ 25)$ and $\Lambda = \text{diag}(25 \ 25)$. The tracking performance of the system was changed according to the values of control parameters α , β , b_1 , λ , ψ , and γ . The values of α , β , b_1 , λ , ψ , and γ can be selected from 1–15, 1–20, 1–20, (–1)–(–20), 1–20, and 1–4, respectively. The control law had better performance with the control parameters $\Gamma = 1$, $\alpha = 12$, $\beta = 18$, $b_1 = 15$, $\lambda = -15$, $\psi = 12$, and $\gamma = 2$, and the obtained results were given in the Figures. As shown in the Figures, the tracking error was very small, the values of $\hat{\pi}_1$ were very small, and the values of $\hat{\rho}$ and $\hat{\rho}_d$ were large compared to $\hat{\pi}_1$ for the proposed adaptive-robust control law in Eq. (38). These results show that proper estimation of the unknown structured and unstructured parameters was achieved and the disturbances and joint frictions were rejected by the proposed adaptive-robust controller.

5. Discussion

The adaptive control law [2,23] is used for large uncertainties but it is a pure unknown dynamic model and external disturbance [9]. Moreover, obtaining the best tracking performance is not possible for the pure adaptive control law in Eq. (44). In the pure adaptive control law in Eq. (44) [2,23], only the parameter estimation law is considered and the estimation of $\hat{\pi}_1$ is given in Figure 7, where the values of $\hat{\pi}_1$ are large and, as a result, a large tracking error is obtained. In order to obtain a small tracking error, the dynamic compensators must be estimated properly. However, a large dynamic compensator $\hat{\pi}_1$ causes a large tracking error and, as a result, obtaining a small tracking error and proper estimation for $\hat{\pi}_1$ is not possible in the pure adaptive control law in Eq. (44). The closed system is stable and $\dot{\tilde{q}}$ and \tilde{q} converge to 0, and this implies that σ is bounded and converges to 0. As a result, $Y^T \sigma$ converges to 0 and $\int Y^T \sigma dt$ is bounded and converges to a constant. However, $\int Y^T \sigma dt$ changes slowly and $\int Y^T \sigma dt$ does not converge to its true value, that is, the most appropriate value that forces the tracking error to be minimum. As a result, a bigger tracking error and bigger $\hat{\pi}_1$ are obtained. The aim of this study was to obtain a small tracking error and, at the same time, to design a proper dynamic compensator. For this purpose, new parameter and bound estimation laws for the pure adaptive control law were considered in order to reduce the tracking error. When $Y^T \sigma$ converges to 0, $\int Y^T \sigma dt$ changes very slowly and a small tracking error and small $\int Y^T \sigma dt$ are obtained. The control parameter $\int Y^T \sigma dt$ is very small and the dynamic compensators $(\beta^2/\alpha)\text{Sin}(2\alpha \int Y^T \sigma dt)$ and $\lambda \text{Cos}(\alpha \int Y^T \sigma dt)$ are estimated properly. The values of $\hat{\pi}_2$ and $\hat{\rho}$ can be adjusted by changing the control parameters α , β , and λ to the appropriate values. The dynamic compensators $\hat{\pi}_1$, $\hat{\pi}_2$, and $\hat{\rho}$ converge to their true values fast, and, as a result, the tracking error is very small and obtaining better tracking performances is possible. As shown in Figures 7, 8, and 9, the estimation of $\hat{\pi}_1$ is very small and $\hat{\pi}_2$, $\hat{\rho}$, and ρ_d change over time. These results show that the proper estimation of $\hat{\pi}_1$, $\hat{\pi}_2$, and $\hat{\rho}$ are achieved.

Development of the estimation function for the unknown unstructured parameters has not been considered before. In this paper, development of the estimation functions for the unknown unstructured parameter was

considered in order to compensate for external disturbances and joint frictions. In the design, a variable function $\phi = \frac{e^{\gamma \int \|\sigma\| dt}}{\psi}$ is used and the unknown unstructured parameters are estimated as a function of $\hat{\rho}_{d2} = \frac{\psi^2}{\gamma}(e^{-\gamma \int \|\sigma\| dt} - e^{-2\gamma \int \|\sigma\| dt})$. In previous studies [12–14], compensators for the unstructured parameters were developed. However, the upper uncertainty bounds on the unstructured parameters are constant; they are a known a priori and the values of the compensators are changed depending on σ . When σ approaches 0, the value of the compensator for the unstructured parameters will decrease and go to 0. As a result, the values of the compensators for the unstructured parameter decrease and better compensation cannot be achieved. In this paper, a new uncertainty bound estimation law for the unstructured parameter was developed. In the design, a variable function is used and a proper uncertainty bound on the unstructured parameter is achieved. When σ goes to 0, $\int \|\sigma\| dt$ goes to a constant. If the tracking error is too small, σ will also be too small, and as a result, $\int \|\sigma\| dt$ will converge to a small constant value. However, the exponential function depending on $\int \|\sigma\| dt$ will not be very small. As a result, a small tracking error is obtained and the proper estimation of ρ_d is achieved. The unknown structured and unstructured parameters are compensated well and better tracking performance is obtained for the proposed adaptive-robust control law in Eq. (38).

References

- [1] J.J. Craig, P. Hsu, S.S. Sastry, “On the adaptive control of robot manipulators”, *The International Journal of Robotics Research*, Vol. 6, pp. 16–28, 1987.
- [2] J.J. Slotine, W. Li, “On the adaptive control of robotic manipulator”, *The International Journal of Robotics Research*, Vol. 6, pp. 49–59, 1987.
- [3] M.W. Spong, “Adaptive control of robot manipulators: design and robustness”, *Proceedings of the American Control Conference*, pp. 2826–2830, 1993.
- [4] R. Burkan, İ. Uzman, “A model of parameter adaptive law with time varying function for robot control”, *Applied Mathematical Modelling*, Vol. 29, pp. 361–371, 2005.
- [5] R. Burkan, “Design of an adaptive control law using trigonometric functions for robot manipulators”, *Robotica*, Vol. 23, pp. 93–99, 2005.
- [6] R. Burkan, “Modelling of a logarithmic parameter adaptation law for adaptive control of mechanical manipulators”, *Robotica*, Vol. 24, pp. 523–525, 2006.
- [7] G. Leitmann, “On the efficiency of nonlinear control in uncertain linear system”, *Journal of Dynamic Systems Measurement and Control*, Vol. 102, pp. 95–102, 1981.
- [8] M. Corless, G. Leitmann, “Continuous feedback guaranteeing uniform ultimate boundedness for uncertain dynamic systems”, *IEEE Transactions on Automatic Control*, Vol. 26, pp. 1139–1144, 1981.
- [9] M.W. Spong, “On the robust control of robot manipulators”, *IEEE Transactions on Automatic Control*, Vol. 37, pp. 1782–1786, 1992.
- [10] E. Yaz, “Comments on ‘On the robust control of robot manipulators’ by M.W. Spong”, *IEEE Transactions on Automatic Control*, Vol. 38, pp. 511–512, 1993.
- [11] K.M Koo, J.H Kim, “Robust control of robot manipulators with parametric uncertainty”, *IEEE Transactions on Automatic Control*, Vol. 39, pp. 1230–1233, 1994.
- [12] M. Danesh, M. Keshmiri, F. Sheikholeslam, “Developing a robot control scheme robust to uncertain model parameters and unstructured dynamics”, *Proceedings of the IEEE Conference on Industrial Electronics and Applications*, pp. 1–6, 2006.

- [13] G. Liu, A.A. Goldenberg, "Uncertainty decomposition-based robust control of robot manipulators", *IEEE Transactions on Control Systems Technology*, Vol. 4, pp. 384–393, 1996.
- [14] G. Liu, "Decomposition-based control of mechanical systems", *Canadian Conference on Electrical and Computer Engineering*, Vol. 2, pp. 966–970, 2000.
- [15] R. Burkan, İ. Uzmay, "Upper bounding estimation for robustness to the parameter uncertainty in trajectory control of robot arm", *Robotics and Autonomous Systems*, Vol. 45, pp. 99–110, 2003.
- [16] R. Burkan, İ. Uzmay, "Logarithmic based robust approach to parametric uncertainty for control of robot manipulators", *International Journal of Robust and Nonlinear Control*, Vol. 15, pp. 427–436, 2005.
- [17] R. Burkan, "Upper bounding estimation for robustness to the parameter uncertainty with trigonometric function in trajectory control of robot arms", *Journal of Intelligent and Robotic Systems*, Vol. 46, pp. 263–283, 2006.
- [18] R. Burkan, "Modelling of bound estimation laws and robust controllers for robustness to parametric uncertainty for control of robot manipulators", *Journal of Intelligent and Robotic Systems*, Vol. 60, pp. 365–394, 2010.
- [19] R. Burkan, "Design parameters and uncertainty bound estimation functions for adaptive-robust control of robot manipulators", *Turkish Journal of Electrical Engineering & Computer Sciences*, Vol. 20, pp. 169–186, 2012.
- [20] R. Burkan, İ. Uzmay, "Variable upper bounding approach for adaptive-robust control in robot control", *Journal of Intelligent and Robotic Systems*, Vol. 37, pp. 427–442, 2003.
- [21] İ. Uzmay, R. Burkan, "Parameter estimation and upper bounding adaptation in adaptive-robust control approaches for trajectory control of robots", *Robotica*, Vol. 20, pp. 653–660, 2002.
- [22] R. Burkan, İ. Uzmay, "Application of logarithmic-based parameter and upper bounding estimation rules to adaptive-robust control of robot manipulators", *European Journal of Control*, Vol. 12, pp. 156–170, 2006.
- [23] L. Sciavicco, B. Siciliano, *Modeling and Control of Robot Manipulators*, New York, McGraw-Hill, pp. 233–236, 1996.
- [24] M.W. Spong, S. Hutchinson, M. Vidyasagar, *Robot Dynamics and Control*, New York, Wiley, pp. 303–305, 2006.
- [25] F.L. Levis, D.M. Dawson, C.T. Abdallah, *Robot Manipulator Control Theory and Practice*, New York, Marcel Dekker, pp. 114–119, 2004.