

DWMT transceiver equalization using overlap FDE for downlink ADSL

Arsla KHAN*, Sobia BAIG, Tabassum NAWAZ

Electrical Engineering Department, COMSATS Institute of Information Technology, Lahore, Pakistan

Received: 09.12.2012

Accepted/Published Online: 06.05.2013

Printed: 30.04.2015

Abstract: Discrete wavelet multitone (DWMT) modulation is a wavelet transform based technique implemented using perfect reconstruction filter banks. It has been recently proposed for various wireline channels such as digital subscriber loops (DSLs) as a solution to the problems posed by a discrete multitone (DMT) transceiver including interblock interference (IBI) and lower spectral efficiency due to the employment of a cyclic prefix (CP) in the guard interval (GI) for DMT symbols. The greater side lobe attenuation offered by wavelet filter banks results in improved spectral containment and lower IBI in DWMT transceivers. However, no standard equalization technique exists for a DWMT based transceiver so as to remove the effect of channel on the transmitted signal in DWMT systems. This paper proposes the application of overlap frequency domain equalization (OFDE) in DWMT modulated systems and compares the bit error rate (BER) performance with time domain equalization (TDE) technique. It is shown through simulation results that minimum mean square error (MMSE) based OFDE can be applied as an equalization technique for a downlink asymmetric DSL (ADSL) channel with lower computational complexity and BER performance comparable to that of TDE.

Key words: AWGN, NEXT, FEXT, DWMT, TDE, overlap FDE

1. Introduction

In the scenario of increasing data rates for ever growing digital communication systems (DCS) applications, DCS are reliable and provide efficient means of communication such as audio and video sharing from the Internet for frequency selective channels like digital subscriber loop (DSL). A successful approach to solve this problem leads us to a technique called multi-carrier modulation (MCM), which was proposed in 1960 [1]. MCM involves partitioning of channels into parallel and independent channels. It mitigates the effect of frequency selective channels by dividing the entire wide band into narrow sub-bands [2]. Thus, the system data rate is reduced by $1/N$ times and symbol duration increases by N times for N number of sub-channels. MCM can be implemented in different ways which include frequency division multiplexing (FDM) [3], orthogonal frequency division multiplexing (OFDM) [4], and discrete multitone (DMT) [5]. Today, different MCM techniques are used in standards such as digital audio broadcast (DAB), HIPERLAN/2, and terrestrial digital video broadcasting (DVB) [6].

DMT is considered a variant of OFDM. It was proposed by Chow and Cioffi specifically for wireline channels, like asymmetric digital subscriber loops (ADSL) and very high bit rate digital subscriber loops (VDSL) [7]. Interest in DMT modulation has increased, due to the possibility of high data rates on dispersive channels like ADSL [8]. DMT modulation has been standardized for ADSL and VDSL [9].

*Correspondence: arslakhan@ciitlahore.edu.pk

Discrete multitone (DMT) is a multicarrier modulation technique based on fast Fourier transform (FFT). A DMT modulated system employs guard intervals, which increases the symbol period, and this process is known as cyclic prefixing (CP). CP eliminates intersymbol interference (ISI) due to the time dispersive channel. However, in order to overcome the deficiencies of higher side lobes in the transmitted signal waveform and greater overhead in the form of CP in FFT based DMT based transceivers, a new multicarrier technique named discrete wavelet multitone (DWMT) was proposed [10,11]. Switching from sine waves to wavelets, as sub-carrier waveforms, results in a wavelet transform (WT). DWMT displays improved resistance against ISI and intercarrier interference (ICI) due to better time-frequency localization [12]. In a DMT transmitted symbol waveform, the first side lobe is almost 13 dBs lower than the main lobe [12]. However, in DWMT symbol waveforms the side lobes are more than 35 dBs lower than the main lobe, which improves spectral containment [12]. This contributes to lower ICI. Moreover, DWMT based systems do not use CP, which makes them spectrally efficient. WT based MCM has been standardized for power line communication (PLC) in IEEE P1901 [13].

To mitigate the effects of frequency selective nature of channel, an efficient equalization technique is required [14]. Extensive research work is going on in the field of DWMT equalization but there is no standard technique available so far. Time domain equalization (TDE) techniques have been proposed in the literature. However, TDE techniques are computationally complex and their complexity increases with the increase in channel length [15]. Therefore, lower complexity frequency domain equalization (FDE) techniques may be explored for ADSL channel equalization using DWMT modulation.

In this paper, we suggest the application of a new frequency domain technique, overlap frequency domain equalization (OFDE), on a DWMT based transceiver for an ADSL channel. OFDE was originally proposed by Tomeba et al. [16]. We have simulated and analyzed the bit error rate (BER) performance of a DWMT transceiver with TDE and OFDE in the presence of additive white Gaussian noise (AWGN) and crosstalk. Simulation results show that performance of both TDE and OFDE are comparable in terms of BER. However, in terms of computational complexity OFDE is efficient as compared to TDE techniques. Thus, OFDE promises a lower complexity equalization technique without any loss in BER performance.

This research paper is divided into different sections as follows. Section 2 is about the ADSL channel with a detailed discussion regarding crosstalk as channel impairment along with its modeling. Section 3 discusses the generic system model of a DWMT transceiver. TDE and FDE techniques are analyzed in Section 4. Section 5 presents OFDE and the mathematical model of the proposed system with OFDE in detail. Simulation results for both TDE and OFDE are discussed in Section 6. Section 7 gives the BER performance and complexity comparison of both TDE and OFDE techniques, while conclusions are reported in Section 8.

2. ADSL channel model with crosstalk

Digital subscriber loop (DSL) is a modern technology that provides high bandwidth on the existing infrastructure of unshielded twisted pairs (UTP) for telephone networks [17]. ADSL is a variant of DSL that was proposed for home users [18]. The ADSL system was first defined in T1.413 [19]. Here, MCM is employed in the form of a DMT modulation technique. However, a new technique called DWMT has been suggested as a modulation technique for DSL channels to provide users with high data rates [20]. Data rates provided by ADSL channels are lower as compared to wireless local area networks (wireless LANs). ADSL2 and ADSL2+ are variants of ADSL. ADSL2 has been standardized in ITU G.992.3 and ITU G.992.4, whereas ADSL2+ is standardized in ITU G.992.5 [21]. A data rate of 12 Mbps is available for downstream ADSL2 while ADSL2+ supports 24 Mbps. Thus, ADSL2+ supports data rates double those of ADSL2 [21]. 802.11g is a wireless LAN standard

that offers data rates of 54 Mbps. Therefore, reliable communication with lower computational complexity is a significant topic of research, and has been focused on in this research paper.

The communication channel used for our system is an ADSL downlink channel. The downlink channel is considered part of the DSL from central office (CO) to an end subscriber. MATLAB software is used to model the ADSL channel for a telephone line, which is modeled as a finite impulse response (FIR) filter. ADSL channel is modeled as a FIR filter because FIR filters are stable and have linear phase as compared to infinite impulse response (IIR) filters. In addition, implementation of FIR filters is easy because of the absence of a feedback path. Impulse response of ADSL channel is presented in Figure 1, which shows that the impulse response of the ADSL channel is symmetric.

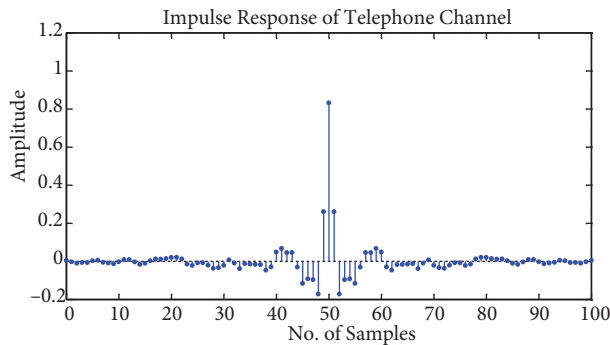

Figure 1. Impulse response of simulated ADSL channel.

2.1. Crosstalk as a channel impairment

The ADSL channel includes a variety of impairments that adversely affect the data. Crosstalk is the most common noise that DSL channels come across [22]. It limits the capacity of the channel. For data transmission, DSL cables are twisted around each other to limit interference. However, due to insufficient shielding between lines, individual wires radiate electromagnetic waves and thus cause interference of the signals on the neighboring lines, due to electric and magnetic fields. Such type of noise, where the signal on one line causes an undesired effect on the other line, is called crosstalk [22]. The ADSL channel poses a challenging environment in the form of crosstalk. Crosstalk can be further categorized into two types depending upon the location of interference [22]:

- Near-end crosstalk (NEXT)
- Far-end cros talk (FEXT)

NEXT is a form of crosstalk that arises on the same end of the other pair, and acts as a source of interference [23]. The local receiver detects the signals from local transmitters of other pair of wires. Thus, signals are coupled whose direction of flow is opposite, but they are generated at the same end of the cable. Crosstalk that occurs at the local receiver due to interfering signals from the remote transmitters is called FEXT [23]. NEXT and FEXT are demonstrated in Figure 2. Consider two pair of wires Pair 1 and Pair 2. The point of consideration Tx1 is transmitting the signals, while Rx2 is receiving the signals. These transmitters and receivers are present at the near-end of each other. Thus, such type of interference is called NEXT. When noise is induced from transmitter to receiver that is present at a remote location then this type of crosstalk is called FEXT.

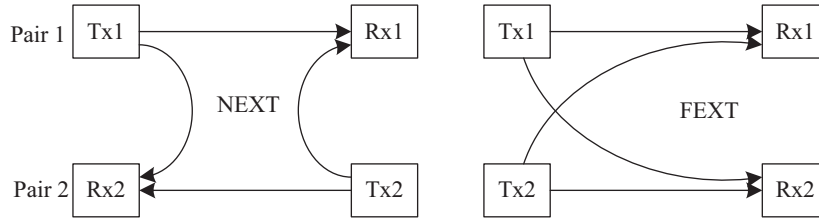

Figure 2. Demonstration of NEXT and FEXT in ADSL channel.

2.2. Modeling of crosstalk

In our simulations, NEXT and FEXT for ADSL is modeled according to standard G.992.1/ G.922.2. Power spectral densities (PSD) of ADSL downstream NEXT, FEXT, and disturbers are expressed as [24]

$$PSD_{NEXT} = PSD_{dis} \times \left[10^{-\frac{NPSL_n}{10}} \times f_{NEXT}^{-\frac{3}{2}} \right] \times f^{\frac{3}{2}} \text{ where } 0 \leq f < \infty \quad (1)$$

$$PSD_{FXT} = PSD_{dis} \times |H_{CH}|^2 \times \left[10^{-\frac{FPSL_n}{10}} \times d_{FXT}^{-1} \times f_{FXT}^{-2} \right] \times d \times f^2 \text{ where } 0 \leq f < \infty \quad (2)$$

$$PSD_{dist} = K \times \frac{2}{f_s} \times \frac{\left[\sin\left(\frac{\pi f}{f_s}\right) \right]^2}{\left(\frac{\pi f}{f_s}\right)^2} \times \frac{1}{1 + \left(\frac{f}{f_{LP3dB}}\right)^{12}} \times \frac{1}{1 + \left(\frac{f_{HP3dB}}{f}\right)^{N_d}} \text{ where } (0 \leq f < \infty) \quad (3)$$

$NPSL_n$ and $FPSL_n$ are the NEXT power sum loss and FEXT power sum loss for disturber pair n respectively. For our simulations n is taken as 24. This value is adopted for all crosstalk simulations. When more than one pair are causing disturbance, then crosstalk produced by all disturber pairs is added and known as the power sum. In Eq. (3), K is the coupling constant, f_s is the sampling frequency in Hz. f_{LP3dB} is the cutoff frequency of the low pass filter. It can be 1104 KHz according to G.992.1 or 552 KHz as standardized in G.992.2. It is used as a shaping filter. The low pass filter used is a 6th order Butterworth filter. f_{HP3dB} is the cutoff frequency of the high pass filter. A high pass filter can be used for two purposes depending upon the order of the filter. If N_d , which is the order of the high pass filter, is equal to 8 then cutoff frequency is set as 25.875 KHz. However, if N_d is equal to 16, then cutoff frequency is considered to be 138 KHz. $N_d = 8$ shows that the high pass filter is used as an echo canceller (EC), which is used to separate the ADSL signals from plain old telephone signals (POTS). If $N_d = 16$ then the high pass filter is used for frequency division multiplexing (FDM), which is utilized to separate the ADSL downstream signals from ADSL upstream signals. H_{CH} is the channel transfer function.

PSD for ADSL downstream NEXT, disturbers, and ADSL downstream FEXT are shown in Figures 3 and 4. PSD of the disturber ranges from -100 to -300 dbm/Hz for 24 disturbers. Modeling parameters of NEXT and FEXT are shown in Table 1.

The ADSL channel model along with crosstalk has been discussed in this section. Efficient and reliable communication over such a frequency selective and noisy channel requires a robust modulation technique, which is proposed to be DWT modulation.

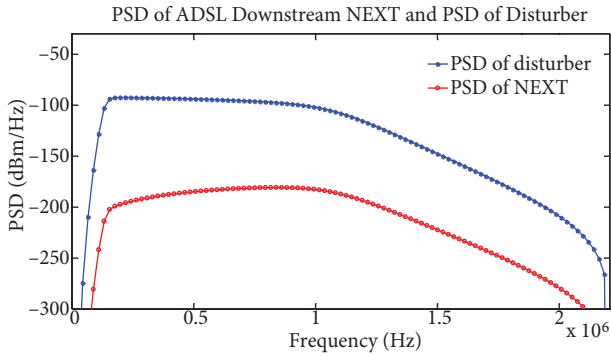

Figure 3. PSD of ADSL downstream NEXT and PSD of disturber.

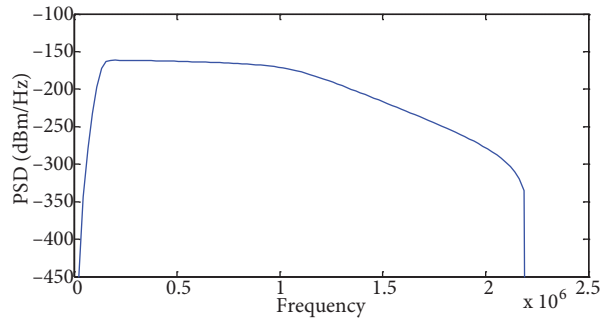

Figure 4. PSD of ADSL downstream FEXT.

Table 1. Modeling parameters of crosstalk.

Parameters	Values
No. of disturbers	24
f_{LP3dB}	$f_s/2, f_s = 2.208$ MHz
f_{HP3dB}	138 KHz
K	0.1104 W
f_{NEXT}	160 KHz
NPSL	47.0 dB
f_{FXT}	160 KHz
d_{FXT}	1.0 km
FPSL	45.0 dB

3. System model

DWMT modulation is a digital multicarrier modulation technique. Its functional block diagram is shown in Figure 5. The structure of the DWMT based transceiver is similar to that of a DMT based transceiver; the only difference lies in the way signals are transformed. The DMT transceiver is based on a Fourier transform while the DWMT based system requires wavelet based filter banks for modulation and demodulation.

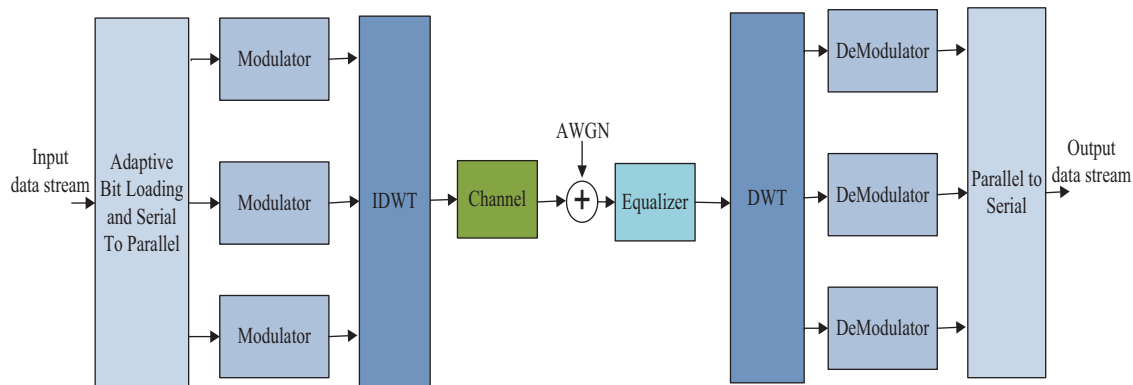

Figure 5. DWMT modulation based digital communication system.

The transmitter accepts the data in the form of a high data rate serial bit stream. During serial to parallel conversion, instead of fixed loading, adaptive bit loading is performed. In our proposed system, a water filling

bit loading algorithm is used for bit loading. Integer numbers of bits are loaded according to the signal to noise (SNR) of each sub-channel. Then bit streams are mapped onto a QAM constellation and form QAM symbols with number of bits per symbol according to the number of bits loaded. These QAM symbols are modulated through a wavelet transform. No CP is required since these symbols overlap in the time domain. On the receiver side, a serial bit stream is formulated. It is then passed through an equalizer to undo the channel effects. After equalization, the stream is passed through the discrete wavelet transform (DWT) block, which is implemented with the help of filter banks as on the transmitted side. The resulting serial stream is converted back into parallel bit streams. These parallel bit streams are input to the QAM decoder for constellation demapping.

The water filling bit loading algorithm allocates a variable number of bits to each sub-channel in accordance with the sub-channel SNR, which is shown in Figure 6 for the ADSL channel shown in Figure 1. Here numbers of bits vary from 0 to 7 for the lowest to highest SNR sub-channel of the ADSL channel. A generalized equalizer is proposed in the block diagram of the DWMT transceiver as shown in Figure 5, which is the topic of discussion in this paper. However, as mentioned in the introduction, these equalizers can be classified into two main classes, i.e. time domain equalization (TDE) and frequency domain equalization (FDE), discussed in detail in the following section.

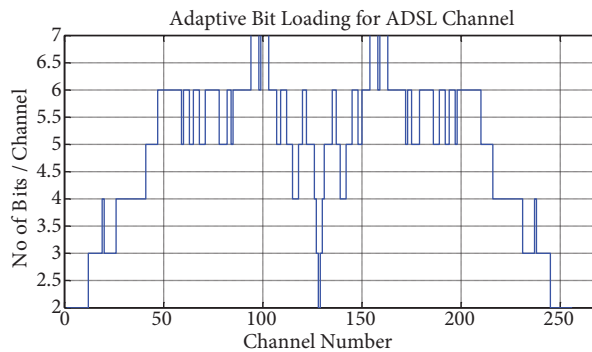

Figure 6. Variable bit loading on ADSL channel.

4. Equalization techniques

DWMT based systems are bandwidth efficient as compared to DMT based systems due to the fact that CP cannot be applied on the time domain overlapping DWMT symbols. However, the simplified frequency domain equalizer standardized in DFT based DMT systems, based on cyclic prefixing, cannot be implemented in the proposed DWMT communication systems. To improve spectral isolation, DWMT systems use multirate filter banks, which make equalization complex, since each sub-channel has to be equalized separately. Therefore, DWMT transceivers require a robust equalization technique with less complexity for recovery of data in dispersive channels like ADSL. Thus, an efficient equalization technique in DWMT with lower complexity is yet to be standardized. Different equalization techniques have been proposed for DWMT based systems, which can be studied in various research works [25–27].

4.1. Time domain equalization (TDE)

Time domain equalization (TDE) is applied for the purpose of channel shortening. TDE outputs are the circular convolution of transmitted symbol and shorten the channel impulse response. It is also called pre-detection equalization, since it is performed before detection or demodulation of the received signal. In TDE

the received signal is considered a continuous signal and thus it is equalized in a continuous manner [28]. The complexity of TDE increases directly with the increase in the length of the channel. Therefore, in the case of large delay spread, the TDE equalizer is a complex and long filter with a large number of taps and thus creates a convergence problem [15]. Different methods have been proposed for the design of time domain equalizers. Two of the most popular methods are minimum mean square error [29] and maximum shortening SNR (MSSNR) [30]. Figure 7 shows a communication system with a time domain equalizer, where $s(t)$ is the transmitted signal that is passed through channel $c(t)$. AWGN is added to it during its transmission through the channel. At the receiver side, the received signal $r(t)$ is first equalized and then it is demodulated.

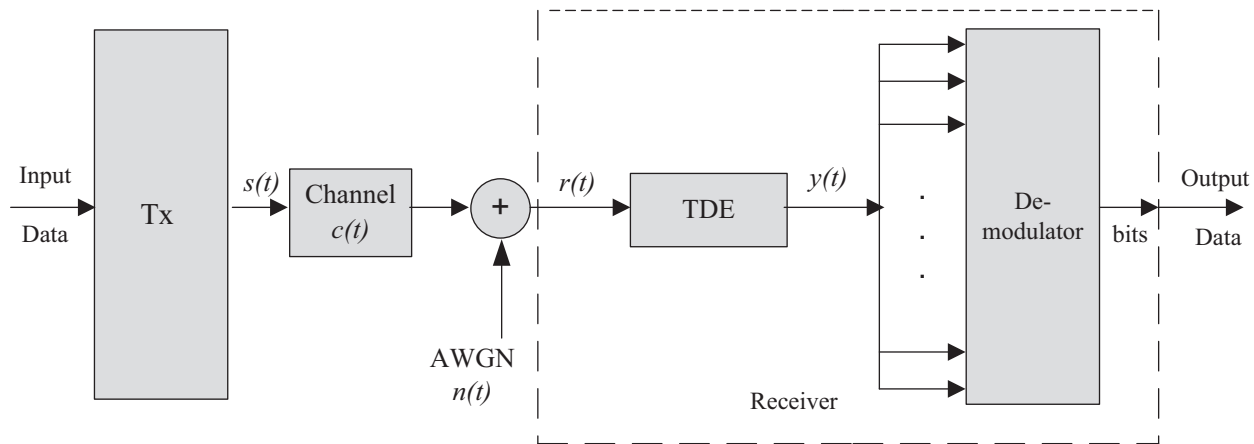

Figure 7. Block diagram of system with TDE.

4.2. Frequency domain equalization (FDE)

FDE is used in those cases where channel delay spread is very large. FDE offers lower complexity compared to TDE, and therefore it is preferred [31]. FDE is considered a block-wise algorithm, where the data signal is assumed as a block [28]. Then FFT of these data blocks is carried out and the data are equalized by multiplying them by the transfer function of the equalizer. Inverse FFT is performed to get the signal back in the time domain. It can be concluded that for FDE the signal is first converted into the frequency domain and then at the end of equalization it is again converted back into the time domain. A block diagram of a system with FDE is shown in Figure 8. The received signal $r(t)$ which is in the time domain, is first converted into the frequency domain. Frequency components are then equalized. After equalization, the signal is demodulated.

5. Overlap frequency domain equalization (OFDE)

The time dispersive nature of channels introduces IBI, which is to be encountered using equalization techniques [32]. GI is usually used to prevent IBI between blocks of data. However, in wavelet OFDM (WOFDM), there is no concept of GI, which results in IBI generation at the beginning and end of the blocks of the received signal data. In conventional frequency domain equalization (FDE), a guard interval (GI) is inserted to overcome the interblock interference (IBI). The GI may include the last few samples of the transmitted symbol or simply zeros may be inserted. Therefore, the GI includes redundant data and thus bandwidth efficiency is reduced. It is normal practice in OFDM systems to apply one fourth of the transmitted symbol as CP in a GI. Hence 25% of bandwidth is wasted in IEEE 802.11a/g based systems because of GI insertion. To overcome this

problem, methods that require insufficient insertion of a GI were studied [33]. Thus, some authors proposed a new method, namely OFDE, which does not require any GI insertion. This method saves precious bandwidth. The cost of this bandwidth efficiency is paid in the form of higher computational complexity [34]. OFDE was first proposed for single carrier systems [35]. Tomeba et al. presented OFDE for the first time in multicarrier systems [16]. They applied OFDE for multi-carrier code division multiple access (MC-CDMA) transmission. Sohaib in [36] utilized OFDE for WOFDM in wireless communication channels in order to overcome the IBI problem. WOFDM uses a wavelet basis instead of a Fourier basis. Despite the fact that the wavelet basis improves the system’s spectral containment and has good time-frequency localization, the WOFDM system still requires equalization because of the channel effect. If OFDE is applied, then IBI can be reduced at the block’s edges.

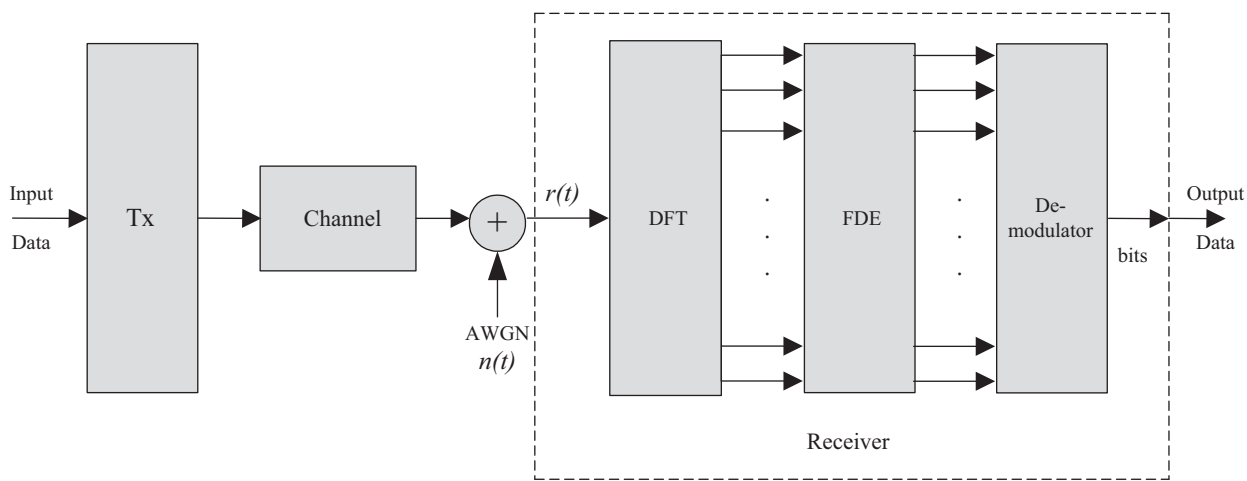

Figure 8. Block diagram of system with FDE.

In OFDE, instead of applying fixed N_c point FFT, where N_c is the number of sub-carriers used, the FFT size is increased to multiples of N_c . Equalization is performed on these mN_c points where m is an integer multiple of N_c . After equalization, N_c points present at the central portion of the blocks are chosen, while those points that are present at the edges of block are discarded [16]. With an increment in the value of m , IBI present at the edges of the block is suppressed; however, at the same time overall computational complexity of the system also increases [16]. OFDE is applied on the receiving side, details of which are given in the next section.

Figure 9 shows the signal processing sequence of overlap FDE [37]. The received sequence consists of blocks of data of length M . Each block is then passed through a $2N_c$ point FFT window. Due to this, the data of M block is spread over a block having length $2N_c$ such that $2N_c > M$. After this procedure, equalization is performed. Now the information is extracted from the center of the block and the data affected by IBI present at the edges of block are eliminated.

5.1. DWMT receiver with OFDE

At the transmitter side the QAM modulated signal $S(x)$ is subjected to IDWT. IDWT is performed using quadrature mirror filter (QMF) banks. Output of IDWT is a combination of two basis functions, i.e. scaling functions and wavelet functions. Both of the basis functions are orthogonal to each other. Output of IDWT

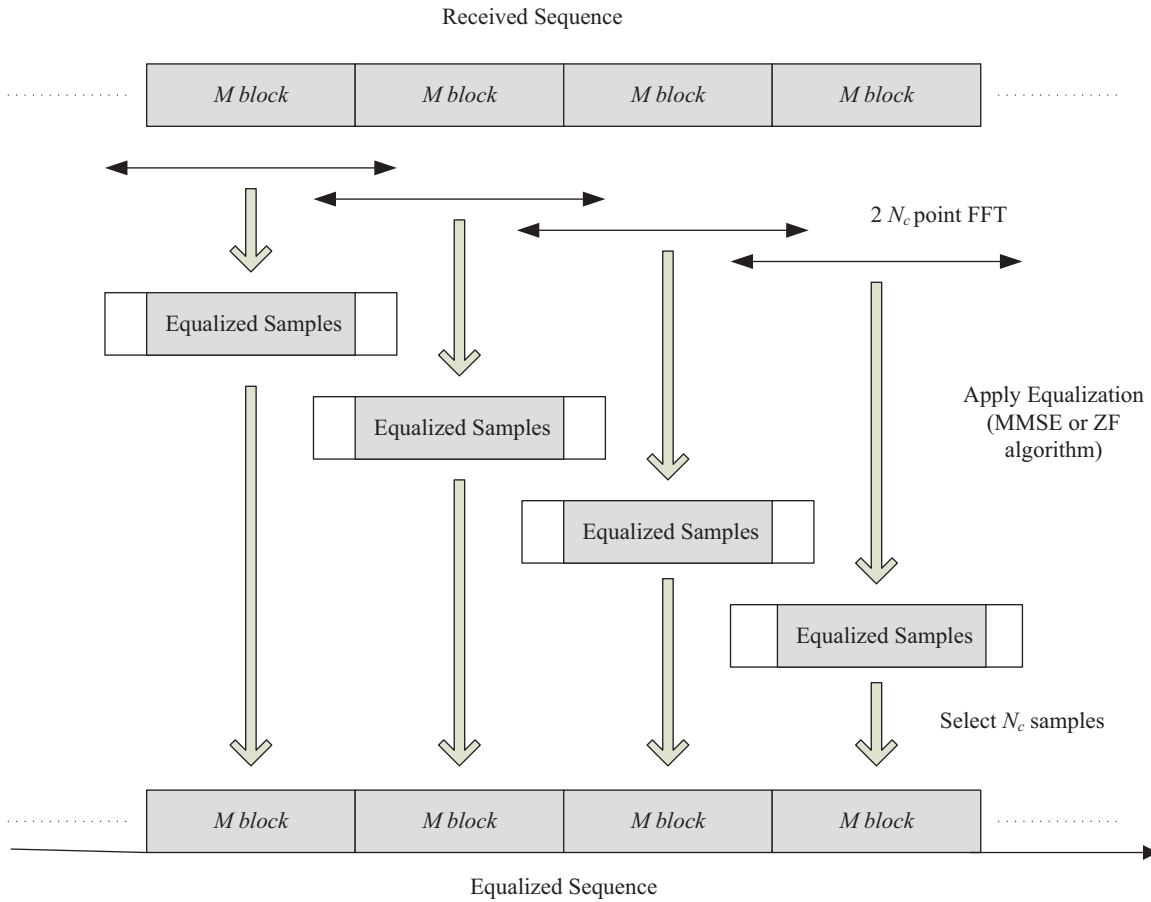

Figure 9. Signal processing of overlap FDE.

can be expressed as [38]

$$s(x) = \sum_{k \in \mathbb{Z}} s_{J,k} \varphi_{J,k}(x) + \sum_{j=-\infty}^J \sum_{k \in \mathbb{Z}} s_{j,k} \psi_{j,k}(x), \quad (4)$$

where $\varphi(x)$ and $\psi(x)$ represent the scaling and wavelet functions, respectively, \mathbb{Z} symbolizes integer numbers, k is a translation index, and j is a scaling index, which is also known as resolution index and defines the wavelet level. J is the coarsest scale and it defines the level of the scaling function. $s_{J,k}$ and $s_{j,k}$ are approximation and detailed coefficients. Scaling and wavelet functions can be expressed as follows [38]:

$$\begin{cases} \text{Scaling equation: } \varphi(x) = \sum_k c(k) \sqrt{2} \varphi(2x - k) \\ \text{wavelet equation: } \psi(x) = \sum_k d(k) \sqrt{2} \psi(2x - k) \end{cases} \quad (5)$$

$c(k)$ and $d(k)$ are dilatation and wavelet coefficients respectively. $s(x)$ is transmitted via ADSL channel to the receiver side. Figure 10 shows the IDWT and DWT operations on the incoming signal on the transmitter and receiver side, respectively.

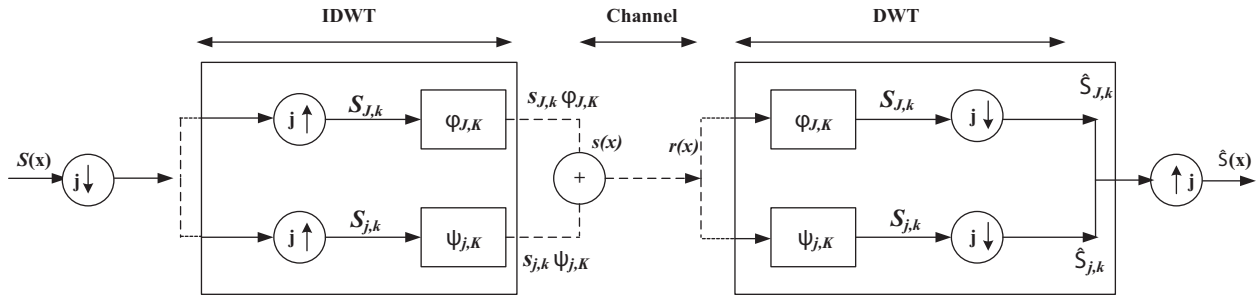

Figure 10. Operations of IDWT and DWT.

The signal received at receiver side $r(x)$ is a convolution of ADSL channel h_l , where l varies from 0 to $L-1$, and transmitted signal $s(x)$ [16].

$$r(x) = \sum_{l=0}^{L-1} h_l s(x-l) \tag{6}$$

Figure 11 shows the receiver portion of the DWMT based transceiver with OFDE. At the receiver side, the received signal $r(x)$ is first expanded from $x = 0 \sim (2N_c - 1)$, where N_c is the total number of sub-carriers, and converted into $r_m(x)$, which is expressed as follows [16]:

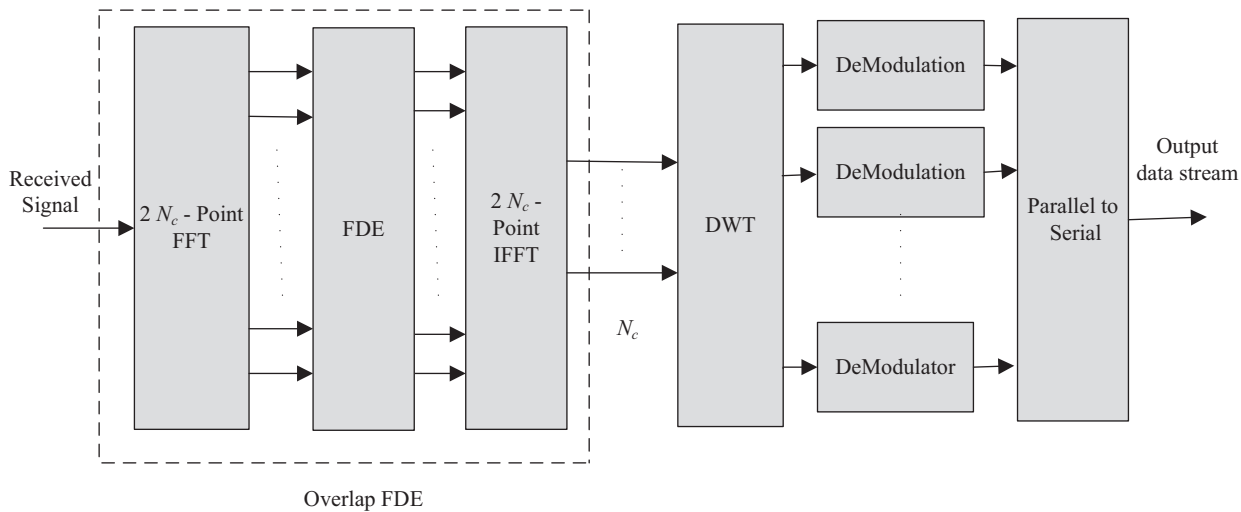

Figure 11. Implementation of DWMT receiver with overlap FDE.

$$r_m(x) = \sum_{l=0}^{L-1} h_l y_m((x-l) \bmod 2N_c) + \nu_m(x) + \eta_m(x) \tag{7}$$

where $y_m(x)$ is the transmitted signal having blocks of length equal to $2N_c$ samples, $\nu_m(x)$ is the IBI, and $\eta_m(x)$ is the additive Gaussian noise (AWGN) with zero mean and variance σ_n^2 . Next $r_m(x)$ is passed through the block of $2N_c$ point FFT, thus converting $r_m(x)$ into $2N_c$ points frequency domain signal $R_m(q)$. $R_m(q)$ can also be expressed as in Eq. (8), where the value of q varies from 0 to $2N_c - 1$ [16].

$$R_m(q) = \frac{1}{2N_c} \sum_{x=0}^{2N_c-1} r_m(x) \exp(-j2\pi q \frac{x}{2N_c}) \tag{8}$$

$$R_m(q) = H(q) Y_m(q) + N_m(q) + \Pi_m(q) \tag{9}$$

where $H(q)$, $Y_m(q)$, $N_m(q)$, and $\Pi_m(q)$ are expressed in the following expression [16]:

$$\begin{cases} Y_m(q) = \frac{1}{2N_c} \sum_{x=0}^{2N_c-1} y_m(x) \exp\left(-j2\pi q \frac{x}{2N_c}\right) \\ N_m(q) = \frac{1}{2N_c} \sum_{x=0}^{2N_c-1} \nu_m(x) \exp\left(-j2\pi q \frac{x}{2N_c}\right) \\ \Pi_m(q) = \frac{1}{2N_c} \sum_{x=0}^{2N_c-1} \eta_m(x) \exp\left(-j2\pi q \frac{x}{2N_c}\right) \\ H(q) = \sum_{l=0}^{L-1} h_l \exp\left(-j2\pi q \frac{l}{2N_c}\right) \end{cases} \tag{10}$$

Here, $Y_m(q)$ is the $2N_c$ point frequency domain representation of the transmitted signal. During its transmission through the channel, it is affected due to IBI, $\Pi_m(q)$ and AWGN, $N_m(q)$. In our case $N_c = 256$. Thus, for 256 sub-carriers, $2N_c$ point FFT decomposes the signal into 512 frequency components.

These frequency components are then sent to the FDE block, where equalization is performed. Equalizer filter coefficients are calculated by either ZF or MMSE. It is observed that the MMSE equalization algorithm performs better as compared to the ZF equalization algorithm [39]. If $H(q)$ is the channel impulse response then taps weights for ZF and MMSE are given as [16]

$$w(q) = \begin{cases} \frac{H^*(q)}{|H(q)|^2} ZF \\ \frac{H^*(q)}{|H(q)|^2 + (\frac{E_s}{N_o})^{-1}} MMSE \end{cases} \tag{11}$$

where E_s is the average energy per symbol while N_o is the power density of AWGN. Equalization is performed by multiplying the received signal $R_m(q)$ by the equalization coefficients, $w(q)$. Equalized signal $R_w(q)$ can be expressed as [16]

$$R_w(q) = R_m(q) w(q) \tag{12}$$

Eq. (13) can be expressed by substituting the $R_m(q)$ from Eq. (9) [16].

$$R_w(q) = [H(q) Y_m(q) + N_m(q) + \Pi_m(q)] w(q) \tag{13}$$

Eq. (14) can be expressed by multiplying $w(q)$ with each term of Eq. (13) [16]

$$R_w(q) = H(q) Y_m(q) w(q) + N_m(q) w(q) + \Pi_m(q) w(q) \tag{14}$$

$$R_w(q) = \hat{H}(q) Y_m(q) + \hat{N}_m(q) + \hat{\Pi}_m(q) \tag{15}$$

where

$$\hat{H}(q) = H(q) w(q)$$

$$\hat{N}_m(q) = N_m(q) w(q) \tag{16}$$

$$\hat{\Pi}_m(q) = \Pi_m(q) w(q)$$

$R_w(q)$ is then subjected to $2N_c$ point inverse FFT (IFFT). After taking IFFT, the equalized signal is expressed as [16]

$$\hat{r}_m(x) = \sum_{q=0}^{2N_c-1} R_w(q) \exp\left(j2\pi x \frac{q}{2N_c}\right) \tag{17}$$

At this stage time domain signal $\hat{r}_m(x)$ has length equal to $2N_c$. Now instead of sending this whole data block of $2N_c$ point length and taking its DWT, central N_c are picked for further processing and the redundant N_c points data are removed and extract the central N_c points data. These central points are expressed as [16]

$$\hat{S}_m(x) = \hat{r}_m\left(x + \frac{N_c}{2}\right) \tag{18}$$

IBI is present at the edges of the data block. Thus, by discarding the data present at the ends of the block, IBI can be avoided. In this way residual IBI present at the edges of blocks is suppressed. N_c data streams are then transformed using DWT for demodulation. DWT of the signal is composed of approximation and detailed coefficients, which are produced due to series expansion. These coefficients are calculated as follows [38]:

$$\hat{S}_{J,k} = \sum_x \hat{S}_m(x) \varphi_{J,k}(x) \tag{19}$$

$$\hat{S}_{j,k} = \sum_x \hat{S}_m(x) \psi_{j,k}(x) \tag{20}$$

These parallel streams are combined into a serial data stream, which gives the recovered signal $\hat{S}(x)$. $\hat{S}(x)$ is the recovered version of the original input signal $S(x)$, which can be utilized to find the mean squared error. Moreover, the received signal's signal to interference ratio (SIR) can be computed to find the probability of error.

6. Simulation results

In this section results obtained from simulations on the DWMT based system for a ADSL downlink channel in the presence of AWGN, FEXT, and NEXT are discussed. For equalization, TDE techniques and OFDE techniques based on ZF and MMSE are applied. Perfect synchronization is considered between the transmitter and receiver.

A performance comparison is made on the basis of *BER*. MATLAB is used as a simulation tool. The simulation parameters are specified in Table 2.

A DWMT based communication system is designed and its performance is analyzed for a time domain ZF algorithm and time domain MMSE algorithm in the presence of AWGN for an ADSL channel in Figure 12. For *BER* of $1E-4$, MMSE has $\frac{E_b}{N_o}$ value of 23 dBs, while ZF has $\frac{E_b}{N_o}$ value of 25 dBs. Thus, for MMSE we get a gain of 2 dBs over the ZF algorithm. The MMSE algorithm's performance is better because it takes into account the affect of AWGN, while the ZF algorithm simply ignores noise effects [40].

The MMSE technique performs better than ZF in both results as shown in Figures 12 and 13. It is because of the fact that ZF tries to remove all ISI and is better only in the scenario where the channel is ideal. In nonideal channels, ZF tries to amplify the noise. The MMSE technique, on other hand, is a balanced technique that does not eliminate ISI completely but tries to minimize the noise power and ISI [41]. As the noise content in our system is increased in the form of crosstalk, the overall system performance degrades.

Table 2. Simulation parameters.

Parameters	DWMT
Channel Bandwidth	1.104 MHz
Sampling Frequency	2.208 MHz
No. of Sub-channels	256
Channel Frequency Spacing	4.3125 KHz
Data Rate without Coding	15.4 Mbps
No. of bits / sub-channel	1 to 7
Modulation Scheme	M -QAM (2, 4, 16, 32, 64, 128)
Wavelet Level	2
Wavelet Family	Haar
Channel Estimation	Ideal
Equalization Techniques	TDE-ZF TDE-MMSE OFDE-ZF OFDE-MMSE

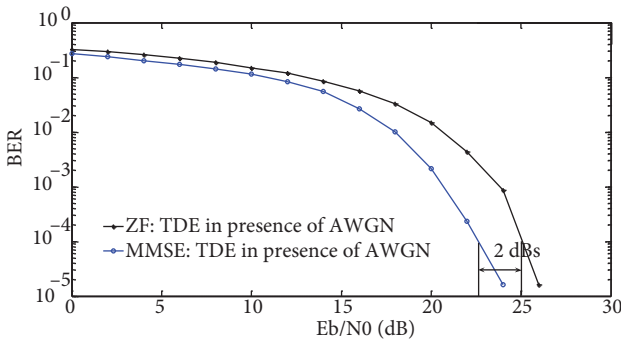

Figure 12. Performance comparison of TDE-ZF and TDE-MMSE for DWMT based system for ADSL channel in presence of AWGN.

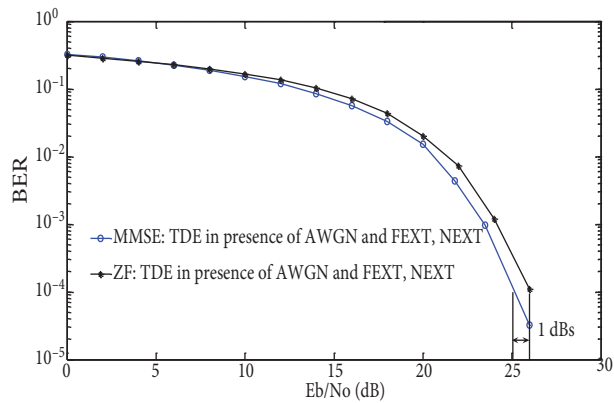

Figure 13. Performance comparison of TDE-ZF and TDE-MMSE for DWMT based system for ADSL channel in presence of AWGN and FEXT, NEXT.

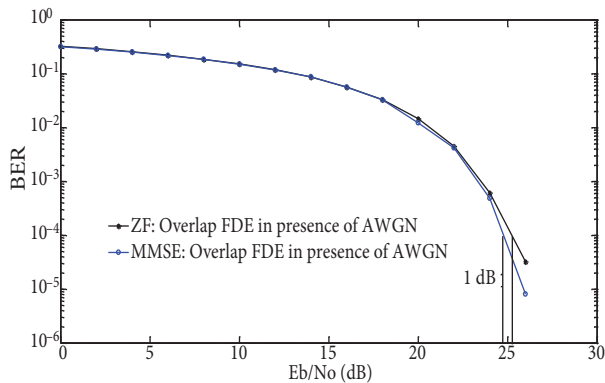

Figure 14. Performance comparison of overlap FDE-ZF and OFDE-MMSE for DWMT transceiver for ADSL channel in presence of AWGN.

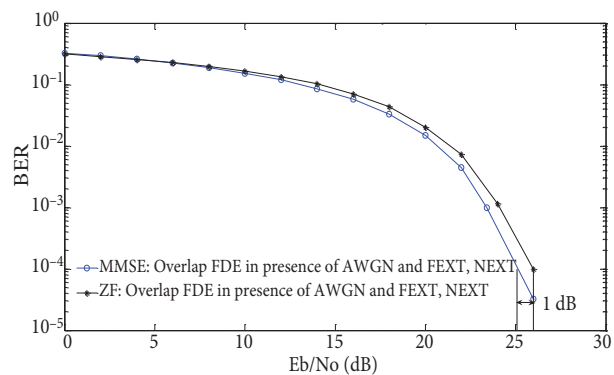

Figure 15. Performance comparison of OFDE-ZF and OFDE-MMSE for DWMT transceiver for ADSL channel in presence of AWGN, FEXT, and NEXT.

Now the performance of the DWMT transceiver for the ADSL downlink channel is analyzed by applying OFDE in the presence of AWGN, FEXT, and NEXT. Figure 14 shows the performance of the system in the presence of AWGN noise only. We can observe that for BER of $1E-4$, ZF based on overlap FDE has $\frac{E_b}{N_o}$ equal to 26 dBs while for MMSE based on OFDE it has a bit energy to noise ratio equal to 25 dBs. Thus, we get a gain of 1 dB in the case of the MMSE algorithm as compared to the ZF equalization algorithm.

In Figure 15 the performance of the DWMT transceiver is observed for OFDE in the presence of AWGN, FEXT, and NEXT while all other conditions remain the same. If we fix BER at $1E-4$ then the MMSE criterion based on overlap FDE has $\frac{E_b}{N_o}$ equal to 25 dBs, whereas the ZF criterion based on OFDE has $\frac{E_b}{N_o}$ equal to 26 dBs. Thus, MMSE based on OFDE equalization performs better than ZF based on OFDE equalization and there is a gain of 1 dB.

7. Performance comparison of TDE and OFDE

TDE techniques are compared with OFDE techniques in terms of BER and computational complexity. These comparisons are shown in Tables 3 and 4, respectively.

Table 3. BER comparison.

Equalization technique	AWGN	AWGN + FEXT, NEXT
BER	$1E-4$	$1E-4$
TDE-MMSE	23 dBs	25dBs
OFDE-MMSE	24 dBs	25 dBs

Table 4. Computational complexity.

Equalization technique	TDE	OFDE
Complexity	$O(N^3)$	$[2(2N_c \log_2 2N_c) + 2N_c]$
If $N, N_c = 256$	16777216	9728

In the DWMT based system, FFT is replaced with DWT. The computation complexity of DWT is $O(N)$, where N is the length of a signal [42]. Thus the computational complexity of DWMT can also be expressed as $O(N)$.

For time domain equalization, the computational complexity is $O(N^3)$, where N is the dimension of the matrix. From [43] it is clear that any matrix with dimension $N \times N$ requires N^3 operations for its inversion. ZF and MMSE have a square matrix and so their computational complexity will also require N^3 operations [44]. Thus, the computation complexity of TDE for both ZF and MMSE is given as $O(N^3)$ [44].

For OFDE the computational complexity is already computed by Adachi in [16]. The complexity for N_c point FFT/IFFT is $[2(2(N_c \log_2 N_c)) + 2N_c]$, where N_c is the size of IFFT/FFT [16]. However, complexity for $2N_c$ point FFT/IFFT is $[2(2N_c \log_2 2N_c) + 2N_c]$, where N_c is the size of IFFT/FFT [16].

$$\text{Overlap FDE for } N_c \text{ point } FFT/IFFT = [2(2(N_c \log_2 N_c)) + 2N_c], \tag{21}$$

$$\text{Overlap FDE for } 2N_c \text{ point } FFT/IFFT = [2(2N_c \log_2 2N_c) + 2N_c]. \tag{22}$$

An important point to note is that N is the length of the wavelet signal, while N_c is the FFT size of the signal. For fair comparison and to make the length of the time domain and frequency domain signal equal, similar values are taken for both variables.

From the above tables, we can observe that, without noticeable performance loss regarding BER, the overlap FDE gives reduced computational complexity as compared to TDE. Thus, the primary purpose of complexity reduction is achieved without much deterioration in BER performance.

8. Conclusion

Very few works exist in the literature on the equalization of communication systems based on multirate filter-banks for ADSL channels. In this paper, we have compared the performance of TDE and OFDE techniques in terms of BER and computational complexity. Equalizer weights are optimized with the help of ZF and MMSE. The performance of both systems is analyzed in the presence of AWGN and crosstalk. From the simulation results we can deduce that the overall computational complexity of the DWMT based system with OFDE is lower than that of the DWMT based system with TDE. In this way, we have gained the complexity reduction advantage by utilizing OFDE for the DWMT based system. The performance evaluation in terms of *BER* did not give significant enhancement for OFDE as compared to TDE techniques. OFDE seems a better option as compared to TDE in terms of complexity without loss in BER performance. As a future work, the authors are interested in evaluating the performance of an equalizer in the presence of impulse noise.

References

- [1] H. Umadevi, K.S. Gurumurthy, "OFDM Technique for Multi-carrier Modulation (MCM) Signaling", *Journal of Emerging Trends in Engineering and Applied Sciences*, Vol. 2, pp. 787–794, 2011.
- [2] H.G. Myung, "Introduction to Single Carrier FDMA", 15th European Signal Processing Conference, pp. 2144–2148, 2007.
- [3] N. Zervos, I. Kalet, "Optimized decision feedback equalization versus optimized orthogonal frequency division multiplexing for high-speed data transmission over the local cable network", *IEEE International Conference on Communications*, Vol. 2, pp. 1080–1085, 1989.
- [4] L.J. Cimini, "Analysis and simulation of a digital mobile channel using orthogonal frequency division multiplexing", *IEEE Transactions on Information Theory*, Vol. 33, pp. 665–675, 1985.
- [5] J.S. Chow, J.C. Tu, J.M. Cioffi, "A discrete multitone transceiver system for HDSL applications", *IEEE Journal on Selected Areas on Communication*, Vol. 9, pp. 895–908, 1991.
- [6] R.V. Nee, R. Prasad, *OFDM for Wireless Multimedia Communications*, Artech House Publishers, 2000.
- [7] P.S. Chow, J.C. Tu, J.M. Cio, "Performance Evaluation of a Multichannel Transceiver System for ADSL and VHDSL Services", *IEEE Journal on Selected Areas in Communication*, Vol. 9, pp. 909–919, 1991.
- [8] J.W. Lechleider, "High bit rate digital subscriber lines: A review of HDSL progress", *IEEE Journal on Selected Areas in Communications*, Vol. 9, pp. 769–784, 1991.
- [9] M. Ding, Z. Shen, B.L. Evans, "An achievable performance upper bound for discrete multitone equalization", *IEEE Global Telecommunications Conference*, Vol. 4, pp. 2297–2301, 2004.
- [10] M.A. Tzannes, M.C. Tzannes, J. Proakis, P.N. Heller, "DMT systems, DWMT systems and digital filter banks", *IEEE International Conference on Communications*, Vol. 1, pp. 311–315, 1994.
- [11] S.D. Sandberg, M.A. Tzannes, "Overlapped discrete multitone modulation for high speed copper wire communications", *IEEE Journal on Selected Areas in Communications*, Vol. 13, pp. 1571–1585, 1995.
- [12] N. Neurohr, M. Schilpp, "Comparison of transmultiplexers for multicarrier modulation", *Proceedings of Fourth International Conference on Signal Processing*, Vol. 1, pp. 35–38, 1998.
- [13] M. Nassar, J. Lin, Y. Mortazavi, A. Dabak, I.H. Kim, B.L. Evans, "Local Utility Power Line Communications in the 3–500 kHz Band: Channel Impairments, Noise, and Standards", *IEEE Signal Processing Magazine*, Vol. 29, pp. 116–127, 2012.

- [14] B. Sklar, *Digital Communications: Fundamentals and Applications*, Prentice Hall, 2001.
- [15] Y. We, X. Zhu, A.K. Nandi, Y. Huang, "Low complexity Turbo space-frequency equalization for single carrier MIMO wireless communications", 14th European Signal Processing Conference, 2006.
- [16] H. Tomeba, K. Takeda, F. Adachi, "BER Performance Analysis of MC-CDMA with Overlap-FDE", *IEICE Transactions on Communications*, Vol. E91-B, pp. 795–804, 2008.
- [17] A. Khan, S. Baig, "Channel equalization for Discrete Wavelet Multitone transceiver in wireline channels", 9th International Bhurban Conference on Applied Sciences and Technology, pp. 394–398, 2012.
- [18] M. Gagnaire, *Broadband local loops for high-speed Internet access*, Artech House, Inc. 2003.
- [19] J.A.C. Bingham, *ADSL, VDSL, and Multicarrier Modulation*, Wiley-Interscience, 2000.
- [20] S. Mustafa, V. Hikmat, S. Shekha, "Wavelet Filter Bank-Based Non Uniform Multi-tone Transceiver for Digital Subscriber Line", *IEEE 11th International Conference on Computer and Information Technology*, pp. 197–203, 2011.
- [21] M. Subramanian, T.A. Gonsalves, N.U. Rani, *Network Management: Principles and Practice*, Pearson Education India, 2010.
- [22] T. Starr, J. Cioffi, P. Silverman, *Understanding Digital Subscriber Line Technology*. Upper Saddle River, NJ: Prentice Hall, 1999.
- [23] J.W. Cook, R.H. Kirkby, M.G. Booth, K.T. Foster, D.E.A. Clarke, G. Young, "The noise and crosstalk environment for ADSL and VDSL systems", *IEEE Communications Magazine*, Vol. 37, pp. 73–78, 1999.
- [24] K.V. Padmaja, B.V. Uma, S. Ravishankar, "Simulation and Implementation of a Practical ADSL Environment on DSP Kit", *World Academy of Science, Engineering and Technology*, pp. 22–27, 2007.
- [25] A. Viholainen, J. Alhava, M. Renfors, "Implementation of parallel cosine and sine modulated filter banks for equalized transmultiplexer system", *Proceedings of IEEE International Conference on Acoustics, Speech, and Signal Processing*, Vol. 6, pp. 3625–3628, 2001.
- [26] K. Izumi, D. Umehara, S. Denno, "Performance Evaluation of Wavelet OFDM Using ASCET", *IEEE International Symposium on Power Line Communications and Its Applications*, pp. 246–251, 2007.
- [27] F.D. Farrukh, S. Baig, M.J. Mughal, "MMSE equalization for discrete wavelet packet based OFDM", *Third International Conference on Electrical Engineering*, pp. 1–4, 2009.
- [28] J. Leibrich, W. Rosenkranz, "Frequency Domain Equalization with Minimum Complexity in Coherent Optical Transmission Systems", *Optical Fiber Communication Conference*, 2010.
- [29] J.S. Chow, J.M. Cioffi, "A cost-effective maximum likelihood receiver for multicarrier systems", *IEEE International Conference on Communications*, Vol. 2, pp. 948–952, 1992.
- [30] P.J.W. Melsa, R.C. Younce, C.E. Rohrs, "Impulse response shortening for discrete multitone transceivers", *IEEE Transactions on Communications*, Vol. 44, pp. 1662–1672, 1996.
- [31] Y. We, X. Zhu, A.K. Nandi, Y. Huang, "Low complexity Turbo space-frequency equalization for single carrier MIMO wireless communications", 14th European Signal Processing Conference, 2006.
- [32] S. Galli, H. Koga, N. Kodama "Advanced signal processing for PLCs: Wavelet-OFDM", *IEEE International Symposium on Power Line Communications and Its Applications*, pp. 187–192, 2008.
- [33] K. Hayashi, H. Sakai, "Interference cancellation schemes for single carrier block transmission with insufficient cyclic prefix", *EURASIP Journal on Wireless Communications and Networking*, 2008.
- [34] W. Bocquet, M. Nakamura, "Novel Frame Structure and Equalization Processing for ZP-OFDM Transmission", *Proceedings of Wireless Personal Multimedia Communications*, Padova, Italy, 2004.
- [35] L. Martoyo, T. Weiss, F. Capar, F.K. Jondral, "Low complexity CDMA downlink receiver based on frequency domain equalization", *IEEE 58th Vehicular Technology Conference*, Vol. 2, pp. 987–991, 2003.

- [36] S. Kiyani, S. Baig, M.J. Mughal, "Overlap Frequency Domain Equalization for Wavelet OFDM", International Technical Conference on Circuits/Systems, Computers and Communications, pp. 1346–1349, 2009.
- [37] T. Obara, K. Takeda, F. Adachi, "Performance Analysis of Single-carrier Overlap FDE", IEEE International Conference on Communication Systems, pp. 446–450, 2010.
- [38] D.P. Radunovic, *WAVELETS from MATHS to PRACTICE*, Springer, 2009.
- [39] S. Hara, R. Prasad, "Overview of multicarrier CDMA", IEEE Communication Magazine, Vol. 35, pp. 126–144, 1997.
- [40] R.G. Gallager, *Principles of Digital Communication*, Cambridge University Press, 2008.
- [41] N.S. Kumar, K.R.S. Kumar, "Bit Error Rate Performance Analysis of ZF, ML and MMSE Equalizers for MIMO Wireless Communication Receiver", European Journal of Scientific Research, Vol. 59, pp. 522–532, 2011.
- [42] A.C. Bovik, *Handbook of image and video processing*, Academic Press, 2000.
- [43] G.H. Golub, C.F. Van Loan, *Matrix Computations*, Johns Hopkins University Press, Baltimore, MD, USA, 1996.
- [44] W.V. Thillo, F. Horlin, J. Nsenga, V. Ramon, A. Bourdoux, R. Lauwereins, "Low-complexity linear frequency domain equalization for continuous phase modulation", Vol. 8, pp. 1435–1445, 1999.