

Choice of battery energy storage for a hybrid renewable energy system

Kusum Lata THARANI^{1,*}, Ratna DAHIYA^{1,2}

¹Department of Electrical and Electronics Engineering, Bharati Vidyapeeth College of Engineering, New Delhi, India

²Department of Electrical Engineering, National Institute of Technology, Kurukshetra, India

Received: 27.07.2017

Accepted/Published Online: 18.12.2017

Final Version: 30.03.2018

Abstract: There are certain unelectrified villages across the Indian subcontinent where providing supply through the grid is difficult due to forest cover or mountainous terrain. The most feasible option is to provide off-grid electrification through renewable energy resources such as solar or wind energy. These intermittent sources do not promise a 24 × 7 supply system. Thus, along with solar or wind energy systems, it becomes important to use a renewable resource, such as biomass, which is available in abundance in rural areas. The need for battery energy storage becomes mandatory in order to store the surplus energy produced by renewable resources and supply it at a time of insufficiency. Currently, many battery technologies are evolving with better characteristics than conventional battery systems in terms of efficiency, response time, deep cycle discharge, lifecycle, etc. The aim of this study is, firstly, to design and model a hybrid renewable energy system (HRES), using photovoltaic (PV)-Biogas (BG) system with HOMER software. Secondly, we aim to test this model using three different battery types: advanced lead acid (LA) batteries, lithium ion (LI) batteries, and zinc-bromine (Zn-Br) flow batteries (FB), used individually. Using these three battery technologies, the HRESs are then compared in terms of system sizing, economy, technical performance, and environmental stability. A case study for the unelectrified village of Madhya Pradesh (MP) is discussed to suggest the practical aspect of the comparative analysis. The results demonstrate that the HRES using LI batteries is the most favorable choice. Using this configuration, the economic parameters, including total net present cost (NPC) and levelized cost of energy (LCOE), are found to be lowest. The technical parameters, including battery state of charge (SOC), capacity shortage, and environmental parameters (CO₂ emissions) are found to be optimum.

Key words: Flow battery, lead acid battery, lithium ion battery, optimization

1. Introduction

Switching to renewable resources from fossil fuels [1] calls for an extensive survey of the available potential of different natural resources in the area to be electrified. According to the Ministry of New and Renewable Energy's 2016–17 report, the state of Madhya Pradesh (MP), considered for the present study, has a solar potential of 61,660 MW, wind potential of 2931 MW, and biomass potential of 1364 MW. It is clear from the above data that the state has 4.5 times more solar potential than wind potential. Therefore, solar energy is taken as one of the resources for generating electricity. However, due to the intermittent nature of solar energy and its variability with cloud cover, the use of a standalone PV system for serving the base load may not be a reliable solution. As there is an abundance of biomass potential in rural areas, the PV system can be used along with a biogas generator [2–9] to serve the domestic and agricultural loads in rural off-grid village areas. The

*Correspondence: kusum.tharani@rediffmail.com

research on rural electrification in [2] considers two different models. Model 1 consists of a solar-biogas system and Model 2 only uses a biogas system. From an economic and environmental point of view, the results show that Model I is more suitable, with a lower total net present cost (NPC), lower levelized cost of energy (LCOE), and less impact on the environment than Model II. Research in [3] considers a PV-biomass and wind-biomass system for the electrification of a rural area. It is quite evident from the results that the PV-biomass system gave a more reliable, economical, and environmentally friendly solution in comparison to the wind-biomass system. The above literature shows that there has been extensive research on the hybrid PV-BG system with battery back-up, and the results show that hybrid systems have a lower total NPC, lower LCOE, and less impact on the environment in comparison to stand-alone PV or BG systems. Therefore, the first objective is to design and model a hybrid PV-BG system with battery back-up as a source for electrifying the village area.

As a matter of fact, very limited research has focused on the type of battery to be used with hybrid PV-BG system for yielding better economics and system performance. In the last decade, not much attention was paid to the type of battery energy storage (BES) to be used when designing a grid-connected or off-grid system. Batteries can be compared on the basis of their cost, cycling, replacement, and, most importantly, their safe disposal. Five different battery types ((lead acid (LA), lithium ion (LI), sodium-based, nickel-based, and flow battery (FB)) are normally used in renewable energy systems. Among these batteries, the sodium-based and nickel-based ones are not considered in this study, because sodium-based batteries use nontoxic materials [10] and have high energy densities; as a result, they need an extra system to ensure a high operating temperature, thereby increasing their high annual operating cost [11]. Similarly, nickel-based batteries present certain drawbacks such as nickel as a toxic material, whose decomposition may lead to environmental hazards [12]. Moreover, the battery suffers from the memory effect: maximum capacity can rapidly decrease if it is repeatedly recharged. Table 1 and Figure 1 show a technical comparison, taken from various literature sources, for the remaining three battery types: LA, LI, and FB. After analyzing the scientific details of all the battery types, the second objective is to use the three different batteries, advanced LA, LI, and Zn-Br FB, one at a time with the designed HRES, and compare the system on the basis of economics, technical performance, and environmental effects.

Table 1. Technical comparison of different battery types.

Parameters	Lead acid [13–17]	Lithium ion [18–20]	Flow battery [21–24]
Unit cell voltage (V)	2	3.7	1.8
Power density (W/L)	10–400	1500–10,000	< 25
Energy density (W h/L)	50	200	35
Cycle life (cycles)	500–2000	1000–5000	> 10,000
Calendar life (years)	5–15	5–20	10–15
DoD (%)	70–80	80–90	100
Round trip efficiency (%)	85	92	75

2. Materials and methods

2.1. HOMER software

HOMER simulation software is used to test the technical and economic feasibility of the HRES model by using three different batteries individually, namely advanced LA, LI, and Zn-Br FB. HOMER is a simulation and

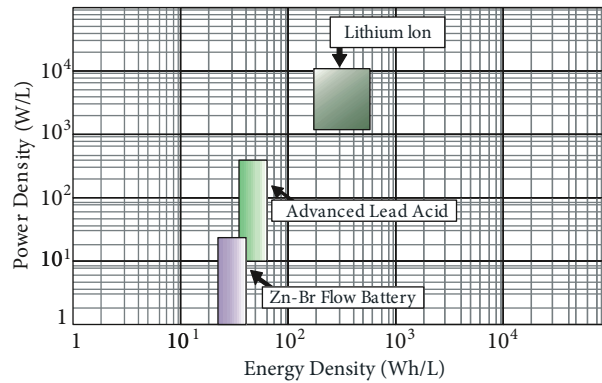

Figure 1. Comparison of power density and energy density for different battery types.

optimization software used for designing distributed generation systems in two different modes: on-grid and off-grid. HOMER uses two optimization algorithms. The first algorithm, “original grid search”, checks the system configurations defined by the user in the search space and simulates all the feasible system configurations. The second, “proprietary derivative-free” algorithm, is used to search for the lowest cost. Finally, a list of all possible configurations sorted by net present cost is displayed, which can be used to compare system design options. HOMER considers three different costs as inputs for each component added to the system design: capital cost per kW, replacement cost per kW, and operation and maintenance (O&M) cost per kW [25].

2.2. System design

The HRES model, shown in Figure 2, highlights the different components of a PV-BG system with battery back-up. It consists of a biogas generator (Bio), an electric load (Electric load #1) that shows a domestic load of 243.81 kWh/day with a peak load of 56.71 kW, and an agricultural load (deferrable load), constituted by three submersible pumps with a total capacity of 17.91 kWh/day with a peak load of 10 kW, all connected to an AC bus. The photovoltaic (PV) system and zinc bromine (ZBM) FB are both connected to the DC bus. The converter is connected between both AC and DC buses.

2.3. Case study

The HRES system model designed in the present study is proposed for the Nishana village in the Betul district of MP. According to the 2011 Census, this unelectrified village is under dense forest cover with 505.8 ha of land and contains 81 households. Each household has a maximum of 2 cattle, generating dung of around 20 kg/day. The total biomass available in the village accounts to approximately 2000 kg/day. The domestic load in each household consists of 4 LED tube lights (18 W each), 2 fans (75 W each), a point for mobile phone charging (5 W), and a color TV (100 W). The energy consumed per day in a single household during the summer season (April–October) is around 2.64 kWh/day, and during the winter season (November–March) is 1.22 kWh/day. The load estimation for the entire village is performed assuming around 100 households after future extension. Three submersible pumps, with a capacity of 0.746 kW each, drawing 40,000 L of water, is installed to irrigate around 2.42 ha of land. The annual energy requirement accounts to approximately 95479 kWh, considering both domestic and agricultural load.

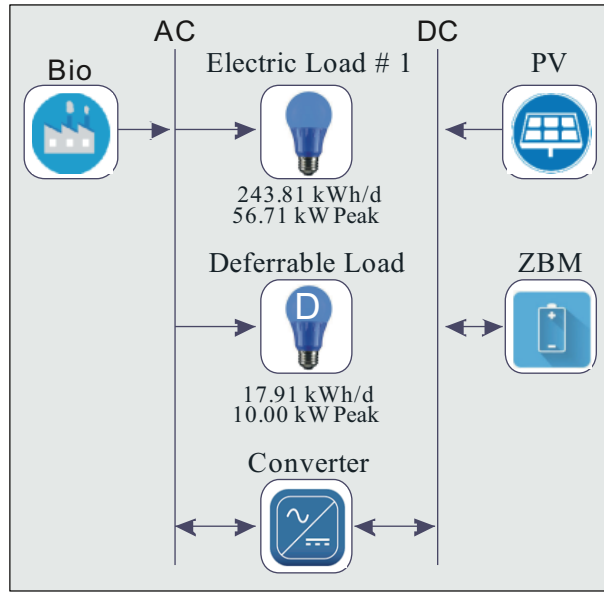

Figure 2. Schematic of system model.

2.4. System components

Generic flat plate polycrystalline PV panels, with 13% efficiency, a life span of 25 years, and a derating factor of 80%, are used. It is estimated that the total PV system capacity required to meet the present load is around 66 kW, if a standalone PV system is used. Thus, different PV sizes (in kW) under consideration for the HRES are in a range of 10 to 70. The converter rating is expected to be 20%–30% more than the total wattage of appliances per day. This accounts for 30–45 kW, whereas different converter sizes (in kW) used in the simulation are in a range of 30 to 45. The generic biogas generator has a lifetime of 20,000 h with a minimum load ratio of 50%. It is estimated that 20–25 kg of cow dung produces around 1.2 kWh of energy. Therefore, in order to produce 95,479 kWh of energy per annum, a biogas generator of approximately 20–30 kW will be required. Different BG sizes (in kW) considered for the study are in a range of 5–30. Three different batteries, used individually, are considered during the simulation in the HRES. Battery capacity (Ah) can be calculated using Eq. (1):

$$\text{Battery capacity} = \frac{\text{Total Watts} - \text{hours per day used by appliances} \times \text{days of autonomy}}{(\text{DOD} \times \text{nominal battery voltage})} \quad (1)$$

Depth of discharge (DoD) is different for different battery types. For advanced LA batteries, DoD is 70%–80%, for LI batteries it is 80%–90%, and for FB, it is 100%, as shown in Table 1.

3. System metrics

During the simulation, different sizes of PV, BG, converter, and batteries are used in each HRES, using LA, LI, or FB batteries. On the basis of the 4 economic metrics and 3 performance metrics discussed in the next section, the most suitable configuration is chosen and proposed to be installed in the village area. A nominal discount rate of 8% with an inflation rate of 2% and project lifetime of 25 years is considered in this study.

3.1. Economic metrics

3.1.1. Total net present cost

The net present cost (NPC), also known as life cycle cost, is calculated for each component installed in the system. It is defined as the present value of capital cost, replacement cost, operation cost, and maintenance cost of a component over the project lifetime, subtracting the present values of revenues earned over the project lifetime. HOMER uses the total NPC, given by Eq. (2), to rank all system configurations in the economic optimization results.

$$\text{Total NPC} = \sum_t^T C_{cap,t} + C_{o\&M,t} + C_{replace,t} + C_{fuel,t} + P_{salvage,t} \quad (2)$$

where T is the lifetime of the project, $C_{cap,t}$ is the present capital cost for year t, $C_{o\&M,t}$ is the present operation and maintenance cost for year t, $C_{fuel,t}$ is the present fuel cost for year t, $C_{replace,t}$ is the present replacement cost for year t, and $P_{salvage,t}$ is the present salvage price for year t. The unit cost data for all the components are shown in Table 2.

Table 2. Unit cost data for different components.

Component	Capital cost	Replacement cost	O&M cost
PV	60,000 INR/kW	60,000 INR/kW	60 INR/kW
BG	70,000 INR/kW	20,000 INR/kW	0.5 INR/hour
Converter	16,000 INR/kW	16,000 INR/kW	0
LA battery	19,500 INR/kW	19,500 INR/kW	100 INR/year
L I battery	39,000 INR/kW	39,000 INR/kW	100 INR/year
Flow battery	54,000 INR/kW	54,000 INR/kW	0

3.1.2. Initial capital cost

The initial capital cost is a fixed one-time investment on the purchase and installation of a component at the beginning of the project. This is an important factor for consideration when off-grid systems are designed.

3.1.3. Replacement cost

Replacement cost is the cost incurred to replace a particular component at the end of its lifetime. Not all components require replacement during the project lifetime. It is always possible to negotiate the initial capital cost with funding agencies and private vendors, but at the time of replacement the real cost of the component to be replaced will have to be shouldered by the buyer. This includes the extra transportation cost at the time of replacement. The off-grid system may require battery and converter replacement twice or three times during the project lifetime.

3.1.4. Cost of energy

The average cost per kWh of useful energy produced by the system is the LCOE in INR/kWh. This is the actual cost metric used to compare grid-connected to off-grid systems. The COE given in Eq. (3) is found to be greater for off-grid systems than grid-connected systems.

$$COE = \frac{AC_{tot}}{T_{pri} + T_{def}} \quad (3)$$

AC_{tot} is the total annualized cost, and T_{pri} and T_{def} are the total amounts of primary and deferrable loads, respectively, that the system serves per year.

3.2. Performance metrics

3.2.1. Battery state of charge

The state of charge (SOC) is an important deciding factor to know the actual remaining capacity of a battery. DoD is an alternate way to indicate the battery's SOC. It is important to monitor the SOC of a battery to prevent it from overcharging, undercharging, or deep-discharging.

3.2.2. Capacity shortage

The maximum value of the capacity shortage fraction allowed by HOMER is an important feasibility criterion. The capacity shortage fraction is given by Eq. (4):

$$F_{CS} = \frac{E_{cs}}{E_{demand}}, \quad (4)$$

where E_{cs} is the total capacity shortage (kWh/year) and E_{demand} is the total electrical demand (primary and deferrable load) in kWh/year. Renewable energy system designers usually do not set the maximum annual capacity shortage to zero. If it is set to zero, that means that the power system will tend to meet 100% of the load demand, considering that the system sizes selected to meet the peak load are quite large and the total NPC of the system will be high. If the load needs to be supplied at all times, only then the maximum annual capacity shortage should be set to zero. Otherwise, if some unmet load is acceptable so as to design a less expensive power system, one may set the maximum annual capacity shortage between 1% and 5%.

3.2.3. Battery autonomy

Battery autonomy is the number of hours the battery can support the critical load without charging. It is a function of SOC, battery capacity, and load size. It is preferable to have at least 2–3 days of battery autonomy, especially during the rainy season when the PV system is part of the HRES.

4. Simulation results

The optimization of the HRES was performed using three different battery types: advanced LA, LI, and Zn-Br FB. The aim was to study the effect of different battery chemistries on system sizing, cost, technical performance of the HRES, and the environment. In an ideal supply–demand situation, the total generation should be sufficient to meet the desired load. This infers that the desired capacity shortage of the HRES should be 0%. However, for the practical implementation of the above condition, a high cost will have to be incurred on the renewable energy sources. Therefore, we choose the right battery type by considering minimum cost, capacity shortage, and environmental hazard.

4.1. System sizing

When designing a HRES, it becomes imperative to decide the share of each renewable energy resource and the capacity of battery storage. It was found that by changing the battery type, the sizes of PV and BG, required to

meet the load with minimum capacity shortage, change. From Figure 3, it is evident that the BG system serves the base load during both summer and winter months. The BG system generates 65%–70% more electricity in comparison to a PV system. From the optimization results shown in Table 3, it was found that the HRES using LI batteries offered the most compact configuration with 26 kW of PV arrays, 28 kW of BG system, 29 kW of converter, and 199 kWh of battery backup. In the HRES using Zn-Br FB, the capacity of the converter and battery required is the lowest, yet the capacity of BG required is the highest (30 kW) in comparison to HRESs using LA or LI batteries. In the HRES using LA batteries, the battery capacity required is the highest (369 kWh) in comparison to the other two configurations.

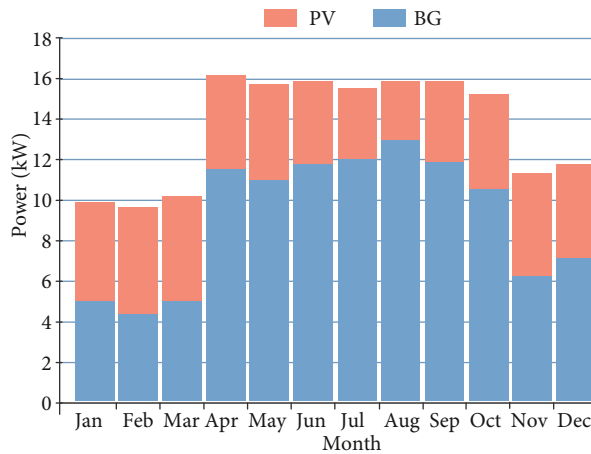

Figure 3. Monthly average electricity production from optimized HRES.

Table 3. Optimal size and cost summary for different configurations.

Model	PV (kW)	BG (kW)	Battery (kWh)	Converter (kW)	Total NPC (INR in millions)	LCOE (INR/kWh)
PV-BG-LA	26	28	369	29	21.4	17.342
PV-BG-LI	26	28	199	29	15.9	12.888
PV-BG-FB	26	30	136	27	17.76	14.393

4.2. Economic analysis

The cash flow summary of HRESs using three different battery types considers capital, replacement, and salvage costs. The O&M costs for the HRESs have been taken as zero, since the PV-BG system is maintained by the local people, and the batteries considered are maintenance-free and are simply replaced after their life span. Figures 4–6 clearly indicate that the cost of battery storage constitutes a major fraction of the total NPC for all three battery types. Therefore, the choice of battery type is of utmost importance. The HRES using LI batteries has the lowest total NPC of 15.9 million INR and the least LCOE of 12.888 INR/kWh, as shown in Table 3. Although the initial capital cost of LA and flow batteries is low in comparison to LI batteries, total NPC and LCOE of the HRES using these batteries are higher. The LA batteries are oversized when designing a practical system, as their efficiency is low and their cycle life is short. This incurs a huge cost on the end user as the battery needs frequent replacement. Therefore, the use of LA batteries is the least preferred for the HRES.

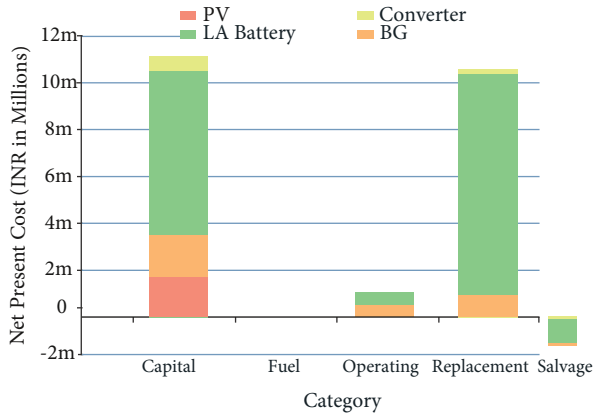

Figure 4. Cash flow summary for PV-BG-LA battery set-up.

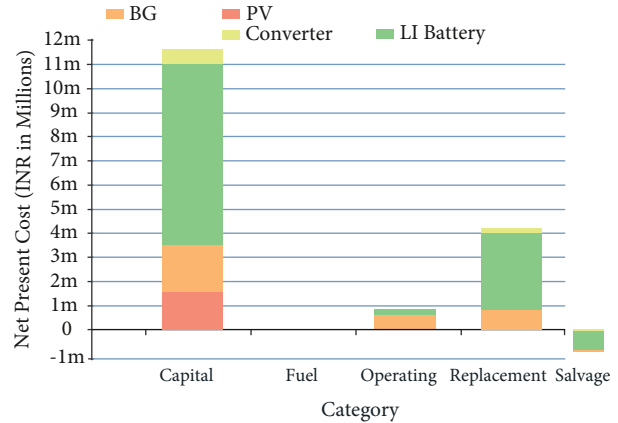

Figure 5. Cash flow summary for PV-BG-LI battery set-up.

4.3. Technical analysis

The performance of a HRES using different battery systems depends on 3 metrics: battery SOC, capacity shortage, and battery autonomy. HRESs, which use advanced LA batteries despite having the highest autonomy of 27 h, are utilized only up to 70% of their full capacity, as shown in Figure 7. HRESs using LI batteries are utilized up to 80% of their full capacity, as shown in Figure 8, with a capacity shortage of 86 kWh/year and autonomy of 13 h. This difference in battery autonomies accounts for the difference in sizing; LA batteries, being oversized, provide maximum autonomy. HRESs using FB offer the least battery autonomy of only 12 hours, with a capacity shortage of 88 kWh/year, and are utilized to their fullest capacity only during several summer months (April, June, August, and September), as shown in Figure 9.

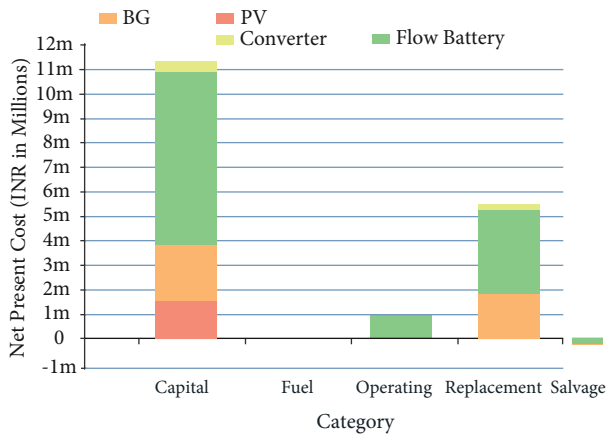

Figure 6. Cash flow summary for PV-BG-Flow battery set-up.

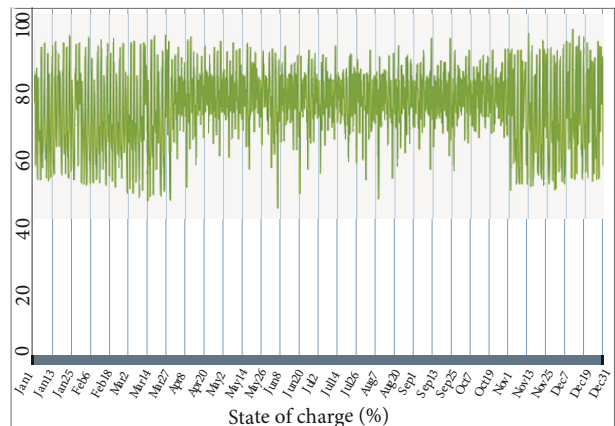

Figure 7. State of charge for LA batteries.

4.4. Environmental effects

The major factors causing environmental hazards in the present HRES are emissions from the biogas generator and, to some extent, the disposal of batteries. Biogas made out of cow dung is a mixture of gasses composed of

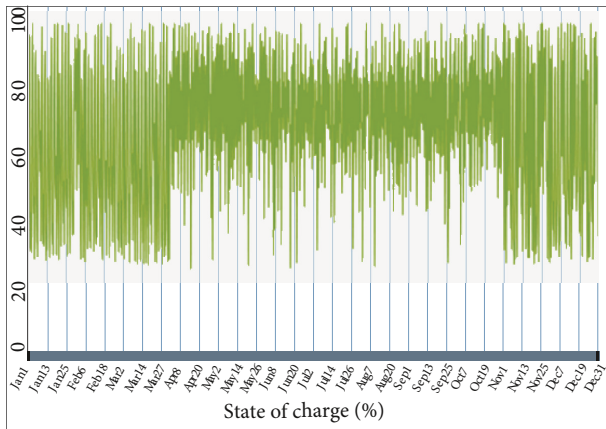

Figure 8. State of charge for LI batteries.

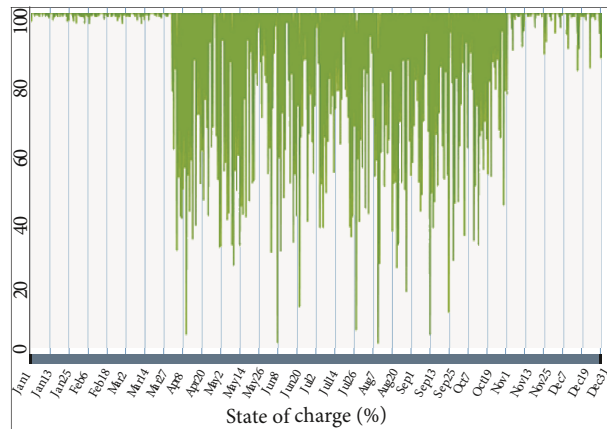

Figure 9. State of charge for Flow batteries.

methane (CH₄), carbon dioxide (CO₂), hydrogen (H₂), and hydrogen sulfide (H₂S). CO₂ gas constitutes the dominant part of the discharge. As shown in Table 4, HRES with FB, requiring the highest capacity of the BG system, produces the maximum CO₂ emissions of around 57 kg/year. HRES using LA and LI batteries release almost the same amount of CO₂, that is, 41 and 40 kg/year, respectively.

Table 4. Battery performance metrics and emission comparison.

Model capacity (kWh)	Usable battery (kWh/year)	Capacity shortage (hours)	Battery autonomy (kg/year)	CO ₂ emissions
PV-BG-LA	222	88	27	41
PV-BG-LI	159	86	13	40
PV-BG-FB	136	88	12	57

5. Recommendations and conclusion

The aim of this paper was to find a solution to two major objectives of the study regarding remote rural electrification in MP. Firstly, a HRES using PV-BG system with battery backup was modeled and simulated using HOMER software. Secondly, the most feasible battery energy storage system was chosen among advanced LA, LI, and Zn-Br FB for the HRES model after comparing them in terms of technical, economic, and environmental concerns. Amongst the three different battery types (advanced LA, LI, and Zn-Br FB) used in the study, the HRES using LI batteries has been recommended for the unelectrified village area. This configuration is found to offer the most compact arrangement, requiring a nominal PV system capacity of 26 kW, a nominal BG rating of 28 kW, and a battery bank rating of 266 kWh. Furthermore, the HRES using LI batteries is the most economical configuration, with the lowest NPC of 15.9 million INR and the least COE of 12.888 INR/kWh. The system proves to be highly efficient with a lowest capacity shortage of 86 kWh/year and the least CO₂ emissions of 40 kg/year. The efficiency of the proposed HRES can be further improved by using different tracking mechanisms with the PV modules. Finally, other renewable sources can be integrated into the existing HRES, and the model can be tested under varying load conditions.

References

- [1] Zhang C, Zhou K, Yang S, Shao Z. On electricity consumption and economic growth in China. *Renew Sust Energy Rev* 2017; 76: 353-368.
- [2] Sharma R, Goel S. Stand-alone hybrid energy system for sustainable development in rural India. *Environment, Development and Sustainability* 2016; 18: 1601-1614.
- [3] Mishra S, Panigrahi CK, Kothari DP. Design and simulation of a solar-wind-biogas hybrid system architecture using HOMER in India. *International Journal of Ambient Energy* 2016; 37: 184-191.
- [4] Lai CS, Jia Y, Xu Z, Lai LL, Li X, Cao J, McCulloch MD. Levelized cost of electricity for photovoltaic/biogas power plant hybrid system with electrical energy storage degradation costs. *Energ Convers Manage* 2017; 153: 34-47.
- [5] Bhatt A, Sharma MP, Saini RP. Feasibility and sensitivity analysis of an off-grid micro hydro-photovoltaic-biomass and biogas-diesel-battery hybrid energy system for a remote area in Uttarakhand state, India. *Renew Sust Energy Rev* 2016; 61: 53-69.
- [6] Singh S, Singh M, Kaushik SC. Feasibility study of an islanded microgrid in rural area consisting of PV, wind, biomass and battery energy storage system. *Energ Convers Manage* 2016; 128:178-190.
- [7] Aziz A. Techno-economic analysis using different types of hybrid energy generation for desert safari camp in UAE. *Turk J Elec Eng & Comp Sci* 2017; 25: 2122-2135.
- [8] Dalton GJ, Lockington DA, Baldock TE. Feasibility analysis of renewable energy supply options for a grid-connected large hotel. *Renew Energy* 2009; 34: 955-964.
- [9] Goel S, Sharma R. Feasibility study of hybrid energy system for off-grid rural water supply and sanitation. *International Journal of Ambient Energy* 2016; 37: 314-320.
- [10] Díaz-González F, Sumper A, Gomis-Bellmunt O, Villafáfila-Robles R. A review of energy storage technologies for wind power applications. *Renew Sust Energy Rev* 2012; 16: 2154-2171.
- [11] Kawakami N, Iijima Y, Fukuhara M, Bando M, Sakanaka Y, Ogawa K. Development and field experiences of stabilization system using 34 MW NAS batteries for a 51 MW wind farm. In: *IEEE 2010 International Symposium on Industrial Electronics*; 4-7 July 2010; Bari, Italy. New York, NY, USA: IEEE. pp. 2371-2376.
- [12] Lacerda VG, Mageste AB, Santos IJB, da Silva LHM, Da Silva MdoCH. Separation of Cd and Ni from Ni-Cd batteries by an environmentally safe methodology employing aqueous two-phase systems. *J Power Sources* 2009; 193: 908-913.
- [13] Achaibou N, Haddadi, Malek A. Lead acid batteries simulation including experimental validation. *J Power Sources* 2008; 185: 1484-1491.
- [14] Bogno B, Sawicki JP, Salame T, Aillerie M, Saint-Eve F, Hamandjoda O, Tibi B. Improvement of safety, longevity and performance of lead acid battery in off-grid PV systems. *Int J Hydrogen Energy* 2017; 42: 3466-3478.
- [15] Lujano-Rojas JM, Dufo-López R, Atencio-Guerra JL, Rodrigues EMG, Bernal-Agustín JL, Catalão JPS. Operating conditions of lead-acid batteries in the optimization of hybrid energy systems and microgrids. *Appl Energy* 2016; 179: 590-600.
- [16] Hadjipaschalis I, Poullikkas A, Efthimiou V. Overview of current and future energy storage technologies for electric power applications. *Renew Sust Energy Rev* 2009; 13: 1513-1522.
- [17] Mariaud A, Acha S, Ekins-Daukes N, Shah N, Markides CN. Integrated optimisation of photovoltaic and battery storage systems for UK commercial buildings. *Appl Energy* 2017; 199: 466-478.
- [18] Anuphapparadorn S, Sukchai S, Sirisamphanwong C, Ketjoy N. Comparison the economic analysis of the battery between Lithium-ion and Lead-acid in PV stand-alone application. *Energy Proced* 2014; 56: 352-358.
- [19] Jaiswal A. Lithium-ion battery based renewable energy solution for off-grid electricity: a techno-economic analysis. *Renew Sust Energy Rev* 2017; 72: 922-934.
- [20] Diouf B, Pode R. Potential of lithium-ion batteries in renewable energy. *Renew Energy* 2015; 76: 375-380.

- [21] Barton JP, Infield DG. Energy storage and its use with intermittent renewable energy. *IEEE T Energy Conver* 2004; 19: 441-448.
- [22] Wu MC, Zhao TS, Jiang HR, Zeng YK, Ren YX. High-performance zinc bromine flow battery via improved design of electrolyte and electrode. *J Power Sources* 2017; 355: 62-68.
- [23] Nakatsuji-Mather M, Saha TK. Zinc-bromine flow batteries in residential electricity supply: two case studies. *IEEE 2012 Power and Energy Society General Meeting*; 22–26 July 2012; San Diego, CA, USA. New York, NY, USA: IEEE. pp. 1-8.
- [24] Ouedraogo BI, Kouame S, Azoumah Y, Yamegueu D. Incentives for rural off grid electrification in Burkina Faso using LCOE. *Renew Energ* 2015; 78: 573-582.
- [25] Shahzad MK, Zahid A, Rashid T, Rehan MA, Ali M, Ahmad M. Techno-economic feasibility analysis of a solar-biomass off grid system for the electrification of remote rural areas in Pakistan using HOMER software. *Renew Energ* 2017; 106: 264-273.