

Affine Manifolds, Log Structures, and Mirror Symmetry

Mark Gross, Bernd Siebert

Abstract

We outline work in progress suggesting an algebro-geometric version of the Strominger-Yau-Zaslow conjecture. We define the notion of a toric degeneration, a special case of a maximally unipotent degeneration of Calabi-Yau manifolds. We then show how in this case the dual intersection complex has a natural structure of an affine manifold with singularities. If the degeneration is polarized, we also obtain an intersection complex, also an affine manifold with singularities, related by a discrete Legendre transform to the dual intersection complex. Finally, we introduce log structures as a way of reversing this construction: given an affine manifold with singularities with a suitable polyhedral decomposition, we can produce a degenerate Calabi-Yau variety along with a log structure. Hopefully, in interesting cases, this object will have a well-behaved deformation theory, allowing us to use the discrete Legendre transform to construct mirror pairs of Calabi-Yau manifolds. We also connect this approach to the topological form of the Strominger-Yau-Zaslow conjecture.

Introduction.

Mirror symmetry between Calabi-Yau manifolds is inherently about degenerations: a family $f : \mathcal{X} \rightarrow S$ of Calabi-Yau varieties where S is a disk, \mathcal{X}_t is a non-singular Calabi-Yau manifold for $t \neq 0$, and \mathcal{X}_0 a singular variety. Much information about the singular fibre is carried in the geometry and topology of the family over the punctured disk: $f^* : \mathcal{X}^* = \mathcal{X} \setminus f^{-1}(0) \rightarrow S^* = S \setminus \{0\}$. For example, in some sense, the degree to which \mathcal{X}_0 is singular can be measured in terms of the monodromy operator $T : H^*(\mathcal{X}_t, \mathbb{Z}) \rightarrow H^*(\mathcal{X}_t, \mathbb{Z})$, where $t \in S^*$ is a basepoint of a simple loop around the origin of S .

An appropriate form of the mirror symmetry conjecture suggests that associated to any sufficiently “bad” degeneration of Calabi-Yau manifolds, i.e. a maximally unipotent degeneration or large complex structure limit point, there should be a mirror manifold $\check{\mathcal{X}}$, defined as a symplectic manifold. Furthermore, if the family $f^* : \mathcal{X}^* \rightarrow S^*$ is polarized, i.e. given a choice of a relatively ample line bundle \mathcal{L} on \mathcal{X}^* , one should expect to be able to construct a degenerating family of complex manifolds $\check{\mathcal{X}}^* \rightarrow S^*$ along with a polarization $\check{\mathcal{L}}$. This correspondence between degenerating polarized families is not precise, though it can be made more precise if one allows multi-parameter families of Calabi-Yau manifolds and subcones of the relatively ample cone of $f^* : \mathcal{X}^* \rightarrow S^*$: this is essentially the form in which a general mirror symmetry conjecture was stated in [24] and we do not wish to elaborate on that point of view here.

Instead, let us ask a number of questions which arise once one begins to think about degenerations of Calabi-Yau manifolds:

(1) Mumford [25] constructed degenerations of n complex dimensional abelian varieties using combinatorial data consisting of periodic polyhedral decompositions of \mathbb{R}^n . This has been developed further by Faltings and Chai [4], Alexeev and Nakamura [2], and Alexeev [1]. Is there an analogue of this construction for Calabi-Yau manifolds? What kind of combinatorial data would be required to specify a degeneration?

(2) If one views a degeneration $\mathcal{X} \rightarrow S$ of Calabi-Yau manifolds as a smoothing of a singular variety \mathcal{X}_0 , can we view mirror symmetry as an operation on *singular varieties*, exchanging \mathcal{X}_0 and $\check{\mathcal{X}}_0$, with the smoothings of these singular varieties being mirror to each other?

(3) When one has a degeneration $f : \mathcal{X} \rightarrow S$, it is a standard fact of life of birational geometry that there may be other birationally equivalent families $f' : \mathcal{X}' \rightarrow S$, with $f^{-1}(S \setminus \{0\}) \cong (f')^{-1}(S \setminus \{0\})$ but $\mathcal{X} \not\cong \mathcal{X}'$. In other words, there may be many different ways of putting in a singular fibre. It is traditional to take a semistable degeneration, where \mathcal{X}_0 has normal crossings, but this may not be the most natural thing to do in the context of mirror symmetry. Is there a more natural class of compactifications to consider?

(4) Can we clearly elucidate the connection between the singular fibre \mathcal{X}_0 and the topology and geometry of the conjectural Strominger-Yau-Zaslow fibration on \mathcal{X}_t for t small?

Let us look at a simple example to clarify these questions. Consider the family of K3 surfaces $\mathcal{X} \subseteq \mathbb{P}^3 \times S$ given by $tf_4 + z_0z_1z_2z_3 = 0$, where t is a coordinate on the disk S and z_0, \dots, z_3 are homogeneous coordinates on \mathbb{P}^3 . Here f_4 is a general homogeneous polynomial of degree 4. Then \mathcal{X}_0 is just the union of coordinate planes in \mathbb{P}^3 , and the total space of \mathcal{X} is singular at the 24 points of $\{t = f_4 = 0\} \cap \text{Sing}(\mathcal{X}_0)$. Thus, while \mathcal{X}_0 is normal crossings, $\mathcal{X} \rightarrow S$ is not semi-stable as \mathcal{X} is singular, and it is traditional to obtain a semi-stable degeneration by blowing up the irreducible components of \mathcal{X}_0 in some order. However, this makes the fibre over 0 much more complicated, and we would prefer not to do this: before blowing up, the irreducible components of \mathcal{X}_0 are toric varieties meeting along toric strata, but after blowing up, the components become much more complex.

A second point is that we would like to allow \mathcal{X}_0 to have worse singularities than simple normal crossings. A simple example of why this would be natural is a generalisation of the above example. Let $\Xi \subseteq \mathbb{R}^n$ be a reflexive polytope, defining a projective toric variety \mathbb{P}_Ξ , along with a line bundle $\mathcal{O}_{\mathbb{P}_\Xi}(1)$. Let $s \in \Gamma(\mathbb{P}_\Xi, \mathcal{O}_{\mathbb{P}_\Xi}(1))$ be a general section. There is also a special section s_0 , corresponding to the unique interior point of Ξ , and s_0 vanishes precisely on the toric boundary of the toric variety \mathbb{P}_Ξ , i.e. the complement of the big $(\mathbb{C}^*)^n$ orbit in \mathbb{P}_Ξ . Then, as before, we can consider a family $\mathcal{X} \subseteq \mathbb{P}_\Xi \times S$ given by the equation $ts + s_0 = 0$. Then \mathcal{X}_0 is the toric boundary of \mathbb{P}_Ξ , but is not necessarily normal crossings. It then seems natural, at the very least, to allow \mathcal{X}_0 to locally look like the toric boundary of a toric variety. Such an \mathcal{X}_0 is said to have *toroidal crossings singularities*. ([27])

These two generalisations of normal crossings, i.e. allowing the total space \mathcal{X} to have some additional singularities and allowing \mathcal{X}_0 to have toroidal crossings, will provide a natural category of degenerations in which to work. In particular, we introduce the notion of a *toric degeneration* of Calabi-Yau manifolds in §1, which will formalise the essential features of the above examples. A toric degeneration $f : \mathcal{X} \rightarrow S$ will, locally away from some nice singular set $Z \subseteq \mathcal{X}$, look as if it is given by a monomial in an affine toric variety. Furthermore, the irreducible components of \mathcal{X}_0 will be toric varieties meeting along toric strata. See Definition 1.1 for a precise definition.

Toric degenerations provide a natural generalisation of Mumford's degenerations of abelian varieties. The key point for us is that there is a generalisation of the combinatorics necessary to specify a degeneration of abelian varieties which can be applied to describe toric degenerations of Calabi-Yau manifolds. To any toric degeneration $f : \mathcal{X} \rightarrow S$ of n complex dimensional Calabi-Yau manifolds, one can build the dual intersection complex B of \mathcal{X}_0 , which is a cell complex of real dimension n . If \mathcal{X}_0 were normal crossings, this would be the traditional dual intersection graph, which is a simplicial complex. The nice thing is that using the toric data associated to the toric degeneration, we can put some additional data on B , turning it into an *integral affine manifold with singularities*. An integral affine manifold is a manifold with coordinate charts whose transition functions are integral affine transformations. An integral affine manifold with singularities will be, for us, a manifold with an integral affine structure off of a codimension two subset.

Under this affine structure, the cells of B will be polyhedra, and the singularities of B will be intimately related to the singular set $Z \subseteq \mathcal{X}$. In the case of a degeneration of abelian varieties, B is just \mathbb{R}^n/Λ , where $\Lambda \subseteq \mathbb{Z}^n$ is a lattice. The polyhedral decomposition of B is the same data required for Mumford's construction. This combinatorial construction will be explained in §2.

To complete the answer to (1), we need a way of going backwards: given an integral affine manifold with singularities along with a suitable decomposition into polyhedra, is it possible to construct a degeneration $f : \mathcal{X} \rightarrow S$ from this? It turns out to be easy to construct the singular fibre from this data. To construct an actual degeneration, we need to use deformation theory and try to smooth \mathcal{X}_0 . However, this cannot be done without some additional data on \mathcal{X}_0 . Indeed, there may be many distinct ways of smoothing \mathcal{X}_0 . To solve this problem, one must place a *logarithmic structure* of Illusie–Fontaine on \mathcal{X}_0 . It is difficult to gain an intuition for logarithmic structures, and we will try to avoid doing too much log geometry in this announcement. Suffice it to say in this introduction that there is some additional structure we can place on \mathcal{X}_0 turning it into a *log scheme*, which we write as \mathcal{X}_0^\dagger . This preserves some of the information associated to the inclusion $\mathcal{X}_0 \subseteq \mathcal{X}$, but can be described without knowing \mathcal{X} . It is then hoped, and definitely is the case in two dimensions, that a log scheme \mathcal{X}_0^\dagger has good deformation theory and can be deformed, and in some cases yield a family $\mathcal{X} \rightarrow S$ as desired. This is as yet the most technically difficult aspect of our program, and has yet to be fully elaborated.

If the above ideas can be viewed as a generalisation of Mumford's construction, they in fact give the key idea to answer question (2). In fact, we cannot define a mirror symmetry

operation which works on singular fibres unless we incorporate a log structure. One of the fundamental points of our program will be to define mirrors of log Calabi-Yau schemes of the sort arising from toric degenerations of Calabi-Yau manifolds.

The main point of this construction is as follows. Given a toric degeneration $\mathcal{X} \rightarrow S$, or just as well \mathcal{X}_0^\dagger , we obtain an affine manifold B along with a polyhedral decomposition \mathcal{P} . If \mathcal{X} , or \mathcal{X}_0^\dagger , is equipped with an ample line bundle, we can also construct the intersection complex of \mathcal{X}_0 . While vertices of the dual intersection complex correspond to irreducible components of \mathcal{X}_0 , it is the maximal cells of the intersection complex which correspond to these same components. However, the presence of the polarization allows us to define an affine structure with singularities on the intersection complex. Thus we have a new affine manifold \check{B} , and a new polyhedral decomposition $\check{\mathcal{P}}$. Most significantly, there is a clear relationship between B, \mathcal{P} and $\check{B}, \check{\mathcal{P}}$. The polarization on \mathcal{X}_0^\dagger can be viewed as giving a convex multi-valued piecewise linear function φ on B , and one can define the *discrete Legendre transform* of the triple $(B, \mathcal{P}, \varphi)$, being a triple $(\check{B}, \check{\mathcal{P}}, \check{\varphi})$, where $\check{B}, \check{\mathcal{P}}$ are as above and $\check{\varphi}$ is a convex multivalued piecewise linear function on \check{B} . These affine structures are naturally dual. This discrete Legendre transform is analogous to the well-known discrete Legendre transform of a convex piecewise linear function on \mathbb{R}^n .

From the data $(\check{B}, \check{\mathcal{P}}, \check{\varphi})$ one can then construct a scheme $\check{\mathcal{X}}_0$ along with a log structure. If \mathcal{X}_0^\dagger and $\check{\mathcal{X}}_0^\dagger$ are smoothable, then we expect that the smoothings will lie in mirror families of Calabi-Yau manifolds.

This construction can be seen to reproduce the Batyrev-Borisov mirror symmetry construction for complete intersections in toric varieties. This is evidence that it is the correct construction. More intriguingly, in a strong sense this is an algebro-geometric analogue of the Strominger-Yau-Zaslow conjecture.

Indeed, we show that given a toric degeneration $\mathcal{X} \rightarrow S$, if B is the corresponding integral affine manifold with singularities, then the integral affine structure on B determines a torus bundle over an open subset of B , and topologically \mathcal{X}_t is a compactification of this torus bundle. Furthermore, it is well-known ([13], [19]) that such affine structures can be dualised via a (continuous) Legendre transform: we are just replacing the continuous Legendre transform with a discrete Legendre transform. As a result, our construction gives both a proof of a topological form of SYZ in a quite general context, including the Batyrev-Borisov complete intersection case, and also points the way towards an algebro-geometrization of the SYZ conjecture.

This paper is meant to serve as an announcement of these ideas, which still are a work in progress. We will give an outline of the approach, and suggest what may be proved using it. A full exploration of this program is currently ongoing. Details of many of the ideas discussed here will appear in [9].

Some aspects of the ideas here were present in earlier literature. The idea that mirror symmetry can be represented by an exchange of irreducible components and information about deepest points was present in an intuitive manner in Leung and Vafa's paper [20]. The idea of using the dual intersection complex (in the normal crossing case) to represent the base of the SYZ fibration first occurred in Kontsevich and Soibelman's paper [18],

and is expanded on in Kontsevich's ideas of using Berkovich spaces [17]. Finally, the idea that logarithmic structures can play an important role in mirror symmetry first appears in [27], which served as a catalyst for this work.

Acknowledgements: We would like to thank Maxim Kontsevich, Simone Pavanelli, Richard Thomas, Stefan Schröer and Ilia Zharkov for useful discussions.

1. Toric degenerations

Definition 1.1. Let $f : \mathcal{X} \rightarrow S$ be a proper flat family of relative dimension n , where S is a disk and \mathcal{X} is a complex analytic space (not necessarily non-singular). We say f is a *toric degeneration* of Calabi-Yau varieties if

1. the canonical bundle $\omega_{\mathcal{X}}$ of \mathcal{X} is trivial.
2. \mathcal{X}_t is an irreducible normal Calabi-Yau variety with only canonical singularities for $t \neq 0$. (The reader may like to assume \mathcal{X}_t is smooth for $t \neq 0$).
3. \mathcal{X}_0 is a reduced Cohen-Macaulay variety, with normalisation $\nu : \tilde{\mathcal{X}}_0 \rightarrow \mathcal{X}_0$. In addition, $\tilde{\mathcal{X}}_0$ is a disjoint union of toric varieties, and if $U \subseteq \tilde{\mathcal{X}}_0$ is the union of big $(\mathbb{C}^*)^n$ orbits in $\tilde{\mathcal{X}}_0$, then $\nu : U \rightarrow \nu(U)$ is an isomorphism and $\nu^{-1}(\nu(U)) = U$. Thus ν only identifies toric strata of $\tilde{\mathcal{X}}_0$. Furthermore, if $S \subseteq \tilde{\mathcal{X}}_0$ is a toric stratum, then $\nu : S \rightarrow \nu(S)$ is the normalization of $\nu(S)$.
4. There exists a closed subset $Z \subseteq \mathcal{X}$ of relative codimension ≥ 2 such that Z satisfies the following properties: Z does not contain the image under ν of any toric stratum of $\tilde{\mathcal{X}}_0$, and for any point $x \in \mathcal{X} \setminus Z$, there is a neighbourhood U_x (in the analytic topology) of x , an $n + 1$ -dimensional affine toric variety Y_x , a regular function f_x on Y_x given by a monomial, and a commutative diagram

$$\begin{array}{ccc} U_x & \xrightarrow{\psi_x} & Y_x \\ \downarrow f|_{U_x} & & \downarrow f_x \\ S & \xrightarrow{\varphi_x} & \mathbb{C} \end{array}$$

where ψ_x and φ_x are open embeddings. Furthermore, f_x vanishes precisely once on each toric divisor of Y_x .

There are two key toric aspects needed here: each irreducible component (or normalization thereof) of \mathcal{X}_0 is toric meeting other components only along toric strata, and f on a neighbourhood of each point away from Z looks like a morphism from a toric variety to the affine line given by a monomial of a special sort. It is important to have both conditions, as mirror symmetry will actually exchange these two bits of toric data.

Key examples to keep in mind were already given in the introduction: a degeneration of quartics in \mathbb{P}^3 to $z_0 z_1 z_2 z_3 = 0$, or a family of hypersurfaces in a toric variety, degenerating to the variety $s_0 = 0$, given by the equation $st + s_0 = 0$. As long as s does not vanish on any toric stratum of \mathbb{P}_{Ξ} , then the degeneration given is toric, with the singular set Z given by

$$Z = \mathcal{X} \cap [(Sing(\mathcal{X}_0) \cap \{s = 0\}) \times S] \subseteq \mathbb{P}_{\Xi} \times S.$$

We will keep these examples in mind as we continue through the paper.

There are more general forms of these degenerations also: instead of weighting a general section s with a single factor t , one can consider equations of the form

$$s_0 + \sum_{s \in \Xi \text{ integral}} t^{h(s)+1} s = 0$$

where h is a suitable height function on the set of integral points of Ξ . Here we have identified the set of integral points of Ξ with a monomial basis for $\Gamma(\mathbb{P}_\Xi, \mathcal{O}_{\mathbb{P}_\Xi}(1))$ as usual. Now the variety \mathcal{X} defined by this equation in $\mathbb{P}_\Xi \times S$ is in general too singular to give rise to a toric degeneration; however, there are standard techniques for obtaining a partial desingularization of \mathcal{X} to yield toric degenerations. This sort of technique has been applied in [29] and [11], and a variant of this in [14], where the goal was to obtain semi-stable degenerations instead of toric degenerations.

There are other examples of toric degenerations: any maximally unipotent degeneration of abelian varieties is toric, and examples of toric degenerations of Kodaira surfaces are given in [26].

2. From toric degenerations to affine manifolds: the dual intersection complex

We fix $M = \mathbb{Z}^n$, $N = \text{Hom}_{\mathbb{Z}}(M, \mathbb{Z})$, $M_{\mathbb{R}} = M \otimes_{\mathbb{Z}} \mathbb{R}$, $N_{\mathbb{R}} = N \otimes_{\mathbb{Z}} \mathbb{R}$. We set

$$\text{Aff}(M_{\mathbb{R}}) = M_{\mathbb{R}} \rtimes GL_n(\mathbb{R})$$

to be the group of affine transformations of $M_{\mathbb{R}}$, with subgroups

$$\begin{aligned} \text{Aff}_{\mathbb{R}}(M) &= M_{\mathbb{R}} \rtimes GL_n(\mathbb{Z}) \\ \text{Aff}(M) &= M \rtimes GL_n(\mathbb{Z}). \end{aligned}$$

Definition 2.1. Let B be an n -dimensional manifold. An *affine structure* on B is given by an open cover $\{U_i\}$ along with coordinate charts $\psi_i : U_i \rightarrow M_{\mathbb{R}}$, whose transition functions $\psi_i \circ \psi_j^{-1}$ lie in $\text{Aff}(M_{\mathbb{R}})$. The affine structure is *integral* if the transition functions lie in $\text{Aff}(M)$. If B and B' are (integral) affine manifolds of dimension n and n' respectively, then a continuous map $f : B \rightarrow B'$ is (integral) affine if locally f is given by affine linear transformations from \mathbb{R}^n to $\mathbb{R}^{n'}$ (\mathbb{Z}^n to $\mathbb{Z}^{n'}$).

Definition 2.2. An affine manifold with singularities is a C^0 (topological) manifold B along with a set $\Delta \subseteq B$ which is a finite union of locally closed submanifolds of codimension at least 2, and an affine structure on $B_0 = B \setminus \Delta$. An affine manifold with singularities is *integral* if the affine structure on B_0 is integral. We always denote by $i : B_0 \hookrightarrow B$ the inclusion map. A continuous map $f : B \rightarrow B'$ of (integral) affine manifolds with singularities is (integral) affine if $f^{-1}(B'_0) \cap B_0$ is dense in B and

$$f|_{f^{-1}(B'_0) \cap B_0} : f^{-1}(B'_0) \cap B_0 \rightarrow B'_0$$

is (integral) affine.

Definition 2.3. A *polyhedral decomposition* of a closed set $R \subseteq M_{\mathbb{R}}$ is a locally finite covering \mathcal{P} of R by closed convex polytopes (called *cells*) with the property that

- (1) if $\sigma \in \mathcal{P}$ and $\tau \subseteq \sigma$ is a face of σ then $\tau \in \mathcal{P}$;
- (2) if $\sigma, \sigma' \in \mathcal{P}$, then $\sigma \cap \sigma'$ is a common face of σ and σ' .

We say the decomposition is *integral* if all vertices (0-dimensional elements of \mathcal{P}) are contained in M .

For a polyhedral decomposition \mathcal{P} and $\sigma \in \mathcal{P}$ we define

$$Int(\sigma) = \sigma \setminus \bigcup_{\tau \in \mathcal{P}, \tau \subsetneq \sigma} \tau.$$

We wish to define a polyhedral decomposition of an affine manifold with singularities generalizing the above notion for a set in $M_{\mathbb{R}}$. This will be a decomposition of B into lattice polytopes with respect to the integral affine structure on B . This definition must be phrased rather carefully, as we need to control the interaction between these polytopes and the discriminant locus Δ of B . In particular, Δ should contain no zero-dimensional cells and not pass through the interior of any n -dimensional cell, but there are subtler restrictions necessary for our purposes. We also need to allow in general for cells to have self intersection. For example, by identifying opposite sides as depicted, the following picture shows a polyhedral decomposition of $B = \mathbb{R}^2/\mathbb{Z}^2$ with one two-dimensional cell, two one-dimensional cells, and one zero-dimensional cell.

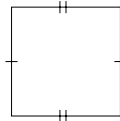

Our definition is

Definition 2.4. Let B be an integral affine manifold with singularities. A *polyhedral decomposition* of B is a locally finite covering \mathcal{P} of B by closed subsets of B (called *cells*) which satisfies the following properties. If $\{v\} \in \mathcal{P}$ for some point $v \in B$, then $v \notin \Delta$ and there exists an integral polyhedral decomposition \mathcal{P}_v of a closed set $R_v \subseteq M_{\mathbb{R}}$ which is the closure of an open neighbourhood of the origin, and a continuous map $\exp_v : R_v \rightarrow B$, $\exp_v(0) = v$, satisfying

- (1) \exp_v is locally an immersion (of manifolds with boundary) onto its image and is an integral affine map in some neighbourhood of the origin.
- (2) For every n -dimensional $\tilde{\sigma} \in \mathcal{P}_v$, $\exp_v(Int(\tilde{\sigma})) \cap \Delta = \emptyset$ and the restriction of \exp_v to $Int(\tilde{\sigma})$ is integral affine.
- (3) $\sigma \in \mathcal{P}$ and $v \in \sigma \Leftrightarrow \sigma = \exp_v(\tilde{\sigma})$ for some $\tilde{\sigma} \in \mathcal{P}_v$ with $0 \in \tilde{\sigma}$.
- (4) Every $\sigma \in \mathcal{P}$ contains a point $v \in \sigma$ with $\{v\} \in \mathcal{P}$.

In addition we say the polyhedral decomposition is *toric* if it satisfies the additional condition

- (5) For each $\sigma \in \mathcal{P}$, there is a neighbourhood $U_\sigma \subseteq B$ of $Int(\sigma)$ and an integral affine submersion $s_\sigma : U_\sigma \rightarrow M'_{\mathbb{R}}$ where M' is a lattice of rank equal to $\dim B - \dim \sigma$ and $s_\sigma(\sigma \cap U_\sigma) = \{0\}$.

Example 2.5. If $B = M_{\mathbb{R}}$, $\Delta = \emptyset$, a polyhedral decomposition of B is just an integral polyhedral decomposition of $M_{\mathbb{R}}$ in the sense of Definition 2.3. If $B = M_{\mathbb{R}}/\Lambda$ for some lattice $\Lambda \subseteq M$, then a polyhedral decomposition of B is induced by a polyhedral decomposition of $M_{\mathbb{R}}$ invariant under Λ .

Explicitly, in the example given above for $B = \mathbb{R}^2/\mathbb{Z}^2$, we have a unique vertex v , and we can take R_v to be a union of four copies of the square in \mathbb{R}^2 :

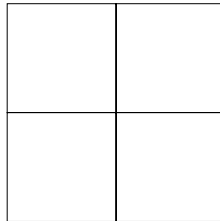

We take \exp_v to be the restriction to R_v of the quotient map $\mathbb{R}^2 \rightarrow \mathbb{R}^2/\mathbb{Z}^2$. Of course, we could have taken $R_v = M_{\mathbb{R}}$ also in this example. Note that in this example, \exp_v is not even an isomorphism in the interior of R_v but just an immersion.

In the case where Δ is empty, the toric condition is vacuous. When B has singularities, the definition of toric polyhedral decomposition imposes some slightly subtle restrictions on how the cells of \mathcal{P} interact with Δ .

Remark 2.6. Given a polyhedral decomposition \mathcal{P} on B , if v is a vertex of \mathcal{P} , we can look at the polyhedral decomposition of R_v in a small neighbourhood of the origin in $M_{\mathbb{R}}$. This clearly coincides with a small neighbourhood of the origin of a complete rational polyhedral fan Σ_v in $M_{\mathbb{R}}$:

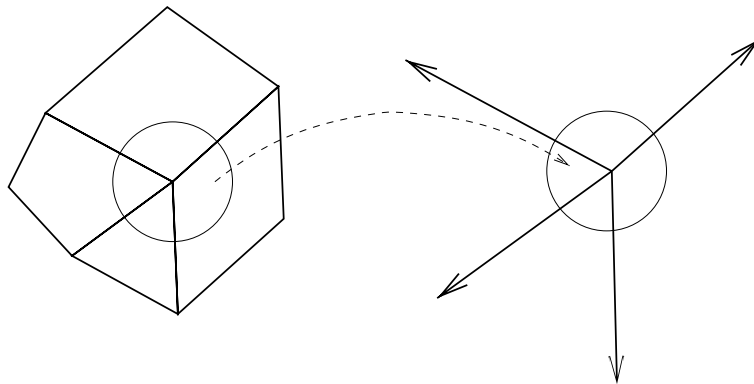

In fact, we shall now see that the data of the affine structures on maximal cells of \mathcal{P} and this fan structure at each vertex v essentially determine the affine structure on B .

Definition 2.7. Recall that if $\sigma \subset M_{\mathbb{R}}$ is a polytope, then the barycentre $Bar(\sigma)$ of σ is the average of the vertices of σ , and thus is invariant under affine transformations. The first barycentric subdivision of σ is then the triangulation of σ consisting of all simplices

spanned by barycentres of ascending chains of cells of σ . Thus given a polyhedral decomposition \mathcal{P} of an affine manifold with singularities B , we can define the first barycentric subdivision $Bar(\mathcal{P})$ of \mathcal{P} to be the triangulation consisting of all images of simplices in the first barycentric subdivisions of all $\tilde{\sigma} \in \mathcal{P}_v$ for all vertices v . Because barycentric subdivisions are affine invariants, this gives a well-defined triangulation of B .

We will now describe a standard procedure for constructing affine manifolds with singularities along with polyhedral decompositions. Let \mathcal{P}' be a collection of n -dimensional integral polytopes in $M_{\mathbb{R}}$. Suppose we are given integral affine identifications of various faces of the polytopes in \mathcal{P}' in such a way that once we glue the polytopes using these identifications, we obtain a manifold B , along with a decomposition \mathcal{P} consisting of images of faces of polytopes in \mathcal{P}' . In particular, we have the identification map

$$\pi : \coprod_{\sigma' \in \mathcal{P}'} \sigma' \rightarrow B.$$

Now B is not yet an affine manifold with singularities. It only has an affine structure defined in the interiors of maximal cells. When two polytopes of \mathcal{P}' are identified along subfaces, we have an affine structure on that subface, but no affine structure in the directions “transversal” to that subface. We cannot, however, expect an affine structure on all of B , and we need to choose a discriminant locus. We do this as follows.

Let $Bar(\mathcal{P})$ be the first barycentric subdivision of \mathcal{P} . We define $\Delta' \subseteq B$ to be the union of all simplices in $Bar(\mathcal{P})$ not containing a vertex of \mathcal{P} or the barycentre of an n -dimensional cell of \mathcal{P} . This can be seen as the codimension two skeleton of the dual cell complex to \mathcal{P} .

For a vertex v of \mathcal{P} , let W_v be the union of the interiors of all simplices in $Bar(\mathcal{P})$ containing v . Then W_v is an open neighbourhood of v , and

$$\{W_v | v \text{ a vertex of } \mathcal{P}\} \cup \{Int(\sigma) | \sigma \text{ a maximal cell of } \mathcal{P}\}$$

form an open covering of $B \setminus \Delta'$. To define an affine structure on $B \setminus \Delta'$, we need to choose affine charts on W_v .

For a vertex v of \mathcal{P} , let

$$\mathcal{P}'_v = \{(v', \sigma') | v' \in \sigma' \in \mathcal{P}' \text{ a vertex, } \pi(v') = v\}.$$

Let R_v be the quotient of $\coprod_{(v', \sigma') \in \mathcal{P}'_v} \sigma'$ by the equivalence relation which identifies proper faces $\omega'_i \subsetneq \sigma'_i$ for $i = 1, 2$, $(v'_i, \sigma'_i) \in \mathcal{P}'_v$, if $\pi(\omega'_1) = \pi(\omega'_2)$ and $v'_i \in \omega'_i$. For example, if \mathcal{P}' consists of the unit square in \mathbb{R}^2 , and B is obtained by identifying opposite sides, we have a unique vertex v in \mathcal{P} and the picture

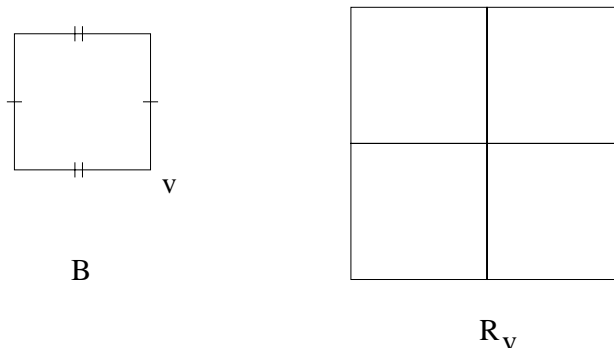

as in Example 2.5 There is a continuous map

$$\pi_v : R_v \rightarrow B$$

defined by taking $b \in \sigma' \subseteq R_v$ to $\pi(b)$, and it is easy to see that if U_v is the connected component of $\pi_v^{-1}(W_v)$ containing 0, then $U_v \rightarrow W_v$ is a homeomorphism.

R_v has an abstract polyhedral decomposition \mathcal{P}_v , with a unique vertex $v' \in U_v$ mapping to v . We will need to find an embedding $i_v : R_v \rightarrow M_{\mathbb{R}}$. If this is done in the appropriate way, then a coordinate chart $\psi_v : W_v \rightarrow M_{\mathbb{R}}$ can be defined as $i_v \circ \pi_v^{-1}|_{W_v}$, and $\exp_v : i_v(R_v) \rightarrow B$ can be defined as $\pi_v \circ i_v^{-1}$, giving both an affine structure on $B \setminus \Delta'$ and a proof that \mathcal{P} is a polyhedral decomposition of B .

To do this, we need to choose a *fan structure* at each vertex v of \mathcal{P} . This means for each v we choose a complete rational polyhedral fan Σ_v in $M_{\mathbb{R}}$ and a one-to-one inclusion preserving correspondence between elements of \mathcal{P}_v containing v' and elements of Σ_v which we write as $\sigma \mapsto \sigma_{v'}$. Furthermore, this correspondence should have the property that there exists an integral affine isomorphism i_{σ} between the tangent wedge of σ at v' and $\sigma_{v'}$ which preserves the correspondence. Such an isomorphism, if it exists, is unique (integrality is essential here as otherwise we can rescale). By this uniqueness, the maps i_{σ} glue together to give a map

$$i_v : R_v \rightarrow M_{\mathbb{R}}$$

which is a homeomorphism onto its image. Then it is easy to see that using ψ_v and \exp_v as defined above one obtains an integral affine structure on B_0 and one sees that \mathcal{P} is a polyhedral decomposition.

Suppose we have made such choices of fan structure, and so obtained an affine structure on $B \setminus \Delta'$ and a polyhedral decomposition \mathcal{P} . It often happens that our choice of Δ' is too crude, and we can still extend the affine structure to a larger open set of B . Let Δ be the smallest subset of Δ' such that the affine structure on $B \setminus \Delta'$ extends to $B \setminus \Delta$ (Such an extension is unique if it exists). The set Δ can be characterized precisely, but we will not do this here. We call Δ the *minimal discriminant locus*.

The main point of this section is that given a toric degeneration of Calabi-Yau manifolds $f : \mathcal{X} \rightarrow S$, there is a natural integral affine manifold with singularities B we can associate to it, the dual intersection complex.

We will construct B as a union of lattice polytopes as in §2, specifying a fan structure at each vertex. Specifically, let the normalisation of \mathcal{X}_0 , $\tilde{\mathcal{X}}_0$, be written as a disjoint union $\coprod X_i$ of toric varieties X_i , $\nu : \tilde{\mathcal{X}}_0 \rightarrow \mathcal{X}_0$ the normalisation. The *strata* of \mathcal{X}_0 are the elements of the set

$$\text{Strata}(\mathcal{X}_0) = \{\nu(S) \mid S \text{ is a toric stratum of } X_i \text{ for some } i\}.$$

Here by toric stratum we mean the closure of a $(\mathbb{C}^*)^n$ orbit.

Let $\{x\} \in \text{Strata}(\mathcal{X}_0)$ be a zero-dimensional stratum. Let $M' = \mathbb{Z}^{n+1}$, $M'_\mathbb{R} = M' \otimes_{\mathbb{Z}} \mathbb{R}$, $N' = \text{Hom}_{\mathbb{Z}}(M', \mathbb{Z})$, $N'_\mathbb{R} = N' \otimes_{\mathbb{Z}} \mathbb{R}$ as usual. Then applying Definition 1.1 (4) to a neighbourhood of x , there is a toric variety Y_x defined by a rational polyhedral cone $\tilde{\sigma}_x \subseteq M'_\mathbb{R}$ such that in a neighbourhood of x , $f : \mathcal{X} \rightarrow S$ is locally isomorphic to $f_x : Y_x \rightarrow \mathbb{C}$, where f_x is given by a monomial, i.e. an element $\rho_x \in N'$. Now put

$$\sigma_x = \{m \in \tilde{\sigma}_x \mid \langle \rho_x, m \rangle = 1\}.$$

Recall that there is a one-to-one correspondence between codimension one toric strata of Y_x and the dimension one faces of $\tilde{\sigma}_x$: these strata are precisely the toric divisors of Y_x . Now the condition that f_x vanishes to order 1 on each such divisor can be expressed as follows. For every one-dimensional face $\tilde{\tau}$ of $\tilde{\sigma}_x$, let τ be a primitive integral generator of $\tilde{\tau}$. Then the order of vanishing of f_x on the toric divisor corresponding to $\tilde{\tau}$ is $\langle \rho_x, \tau \rangle$. Since this must be 1, we see in fact that σ_x is the convex hull of the primitive integral generators of the one-dimensional faces of $\tilde{\sigma}_x$. If we put $M = \{m \in M' \mid \langle \rho_x, m \rangle = 1\}$, $M_\mathbb{R} = \{m \in M'_\mathbb{R} \mid \langle \rho_x, m \rangle = 1\}$, then σ_x is a lattice polytope in the affine space $M_\mathbb{R}$.

What is less obvious, but which follows from the triviality of the canonical bundle of \mathcal{X}_0 , is that σ_x is in fact an n -dimensional lattice polytope.

Example 2.8. If at a point $x \in \mathcal{X}_0$ which is a zero-dimensional stratum, the map $f : \mathcal{X} \rightarrow S$ is locally isomorphic to $\mathbb{C}^{n+1} \rightarrow \mathbb{C}$ given by $(z_0, \dots, z_n) \mapsto \prod_{i=0}^n z_i$, we say f is normal crossings at x . In this case, the relevant toric data is as follows: $\tilde{\sigma}_x$ is generated by the points $(1, 0, \dots, 0), \dots, (0, \dots, 0, 1)$ in \mathbb{R}^{n+1} , and the map is given by the monomial determined by $(1, 1, \dots, 1) \in \text{Hom}_{\mathbb{Z}}(\mathbb{Z}^{n+1}, \mathbb{Z})$. Then σ is the standard simplex in the affine space

$$\{(x_0, \dots, x_n) \mid \sum_{i=0}^n x_i = 1\}$$

with vertices the standard basis of \mathbb{R}^{n+1} .

We can now describe how to construct B by gluing together the polytopes

$$\{\sigma_x \mid \{x\} \in \text{Strata}(\mathcal{X}_0)\}.$$

We will do this in the case that every irreducible component of \mathcal{X}_0 is in fact itself normal so that $\nu : X_i \rightarrow \nu(X_i)$ is an isomorphism. The reader may be able to imagine the more general construction.

Note in this case there is a one-to-one inclusion reversing correspondence between faces of σ_x and elements of $Strata(\mathcal{X}_0)$ containing x . We can then identify faces of σ_x and $\sigma_{x'}$ if they correspond to the same strata of \mathcal{X}_0 . Some argument is necessary to show that this identification can be done via an integral affine transformation, but again this is not difficult.

Making these identifications, one obtains B . One can then prove

Lemma 2.9. *If \mathcal{X}_0 is n complex dimensional, then B is an n real dimensional manifold.*

The key point again here is the triviality of the canonical bundle.

As explained above, to give B the structure of an affine manifold with singularities, we just need to specify a fan structure at each vertex of B . Now the vertices v_1, \dots, v_m of B are in one-to-one correspondence with the irreducible components X_1, \dots, X_m of \mathcal{X}_0 by construction. Each X_i is toric, hence defined by a complete fan Σ_i living in $M_{\mathbb{R}}$. For a vertex v_i , the maximal cones of Σ_i are in one-to-one correspondence with the zero-dimensional strata of X_i . In fact, if σ is a maximal cell of B corresponding to a zero-dimensional stratum of X_i , then $v_i \in \sigma$ and there is a natural integral affine isomorphism between the corresponding cone of Σ_i and the tangent wedge of σ at v_i . It is not hard to see this collection of isomorphisms gives a fan structure at each vertex v_i , thus getting an integral affine manifold with singularities, along with a polyhedral decomposition \mathcal{P} .

Examples 2.10. (1) In case f is normal crossings away from the singular set Z , B is the traditional dual intersection complex: B is a simplicial complex with vertices v_1, \dots, v_m corresponding to the irreducible components X_1, \dots, X_m of \mathcal{X}_0 , and with a p -simplex with vertices v_{i_0}, \dots, v_{i_p} if $X_{i_0} \cap \dots \cap X_{i_p} \neq \emptyset$. However, the affine structure carries more information than the traditional dual intersection complex because of the fan structure.

(2) Let $f : \mathcal{X} \rightarrow S$ be a degeneration of elliptic curves, with \mathcal{X}_0 being a fibre of Kodaira type I_m , i.e. a cycle of m rational curves. Furthermore, assume the total space \mathcal{X} is non-singular. To ensure the irreducible components of \mathcal{X}_0 are normal, we take $m \geq 2$. Then f is normal crossings, and B is a cycle of m line segments of length 1. There is a unique fan structure here, with a neighbourhood of each vertex identified with a neighbourhood of 0 in the unique fan defining \mathbb{P}^1 :

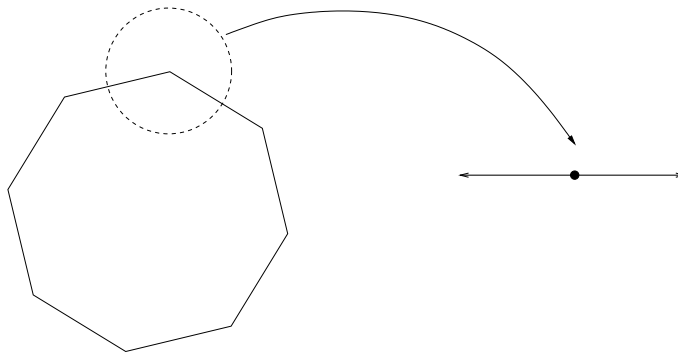

As an affine manifold, B is just $\mathbb{R}/m\mathbb{Z}$, with the affine structure induced by the standard one on \mathbb{R} .

(3) To get a simple example which is not normal crossings, one can start with the above example and contract some chains of rational curves, so that \mathcal{X}_0 is still a cycle of rational curves, but the total space \mathcal{X} now has singularities given locally by the equation $xy = z^n$ in \mathbb{C}^3 for various n (where $n - 1$ is the length of the chain contracted to create the singularity). Locally, the map is given by $(x, y, z) \mapsto z$. At such a point, the cone giving such a local description is $\tilde{\sigma}$ generated by $(1, 0)$ and $(1, n)$ in $\mathbb{R}^2 = M'_{\mathbb{R}}$, with the map given by $(1, 0) \in N'$. Thus the corresponding σ is a line segment of length n .

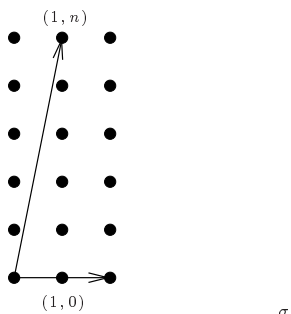

Thus contracting a chain of \mathbb{P}^1 's in (2) above has the effect of keeping B fixed but changing the polyhedral decomposition by erasing all vertices corresponding to these rational curves which have been contracted.

(4) A degenerating family of K3 surfaces: take $tf_4 + x_0x_1x_2x_3 = 0$ in $\mathbb{C} \times \mathbb{P}^3$ as usual. Then f is normal crossings at each triple point of \mathcal{X}_0 , so B is obtained by gluing together four standard simplices to form a tetrahedron. The chart for the affine structure in a neighbourhood of a vertex v identifies that neighbourhood with a neighbourhood of zero of the fan Σ defining \mathbb{P}^2 ; given the combinatorial correspondence between the cells of B containing v and the cones of the fan Σ , there is a unique such chart which is integral affine on the interior of each 2-cell containing v .

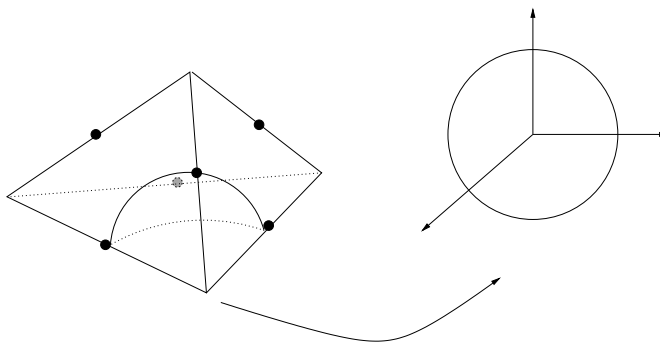

In this example we have one singular point along each edge of the tetrahedron indicated by the dots. These singularities cannot be removed. To see this, consider two vertices v_1 and v_2 . We can take R_{v_1} and R_{v_2} in the definition of polyhedral decomposition to look like

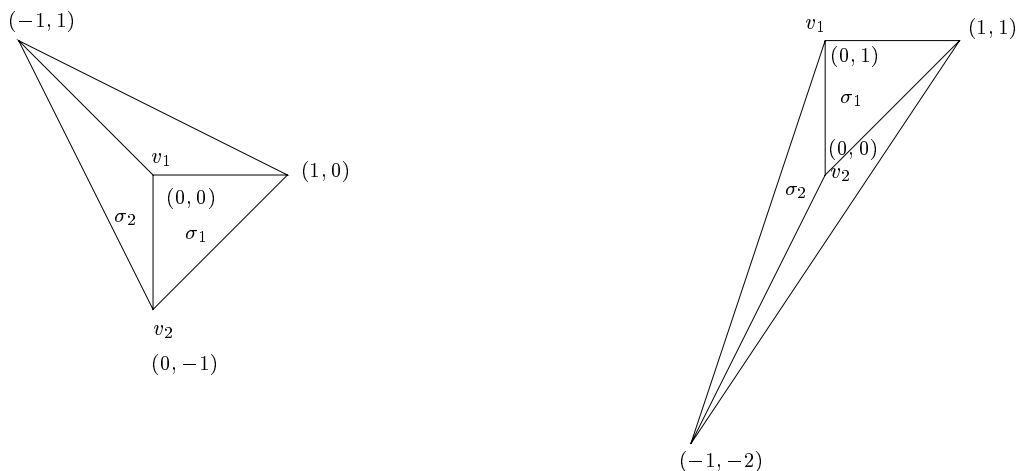

This gives both the correct affine structure on each two-cell (making it isomorphic to the standard two-simplex) and the correct fan structure at the vertices v_1 and v_2 . Note that σ_1 has the same shape in each chart, so these are identified under the maps \exp_{v_i} up to translation. However, up to translation, the linear transformation $\begin{pmatrix} 1 & 0 \\ 4 & 1 \end{pmatrix}$ is required to transform σ_2 in R_{v_1} to σ_2 in R_{v_2} . Thus one finds that if one follows the affine coordinates along a loop starting at v_2 , into σ_1 to v_1 and into σ_2 back to v_2 , they will undergo an affine transformation (called the holonomy around the loop) whose linear part is the linear transformation $\begin{pmatrix} 1 & 0 \\ 4 & 1 \end{pmatrix}$. Thus in particular, there is no way to extend the affine structure across the point in Δ on the line segment joining v_1 and v_2 .

(5) One can carry out this procedure for degenerations of hypersurfaces or complete intersections in toric varieties. In the hypersurface case, one obtains the same affine manifolds with singularities described in [11], or in the case of the quintic, in [8]. Details will be given elsewhere.

3. From affine manifolds to toric degenerations

The most important aspect of our proposed construction is the ability to reverse the construction of the previous section. Given an integral affine manifold with singularities B and a toric polyhedral decomposition \mathcal{P} , we wish to construct a toric degeneration $\mathcal{X} \rightarrow S$ coming from this data.

The first step of the construction is easy, i.e. the construction of \mathcal{X}_0 . Let B, \mathcal{P} be as above. Again, for simplicity, we will assume that no $\sigma \in \mathcal{P}$ is self-intersecting: this is equivalent to the irreducible components of \mathcal{X}_0 being normal. In particular, the endpoints of any edge in \mathcal{P} are distinct. Let v_1, \dots, v_m be the vertices of \mathcal{P} . Then the tangent space \mathcal{T}_{B, v_i} contains a natural integral lattice induced by the integral structure, (the lattice generated by $\partial/\partial y_1, \dots, \partial/\partial y_n$, where y_1, \dots, y_n are local integral affine coordinates). Identifying this lattice with M and \mathcal{T}_{B, v_i} with $M_{\mathbb{R}}$, and identifying a neighbourhood of v_i with a neighbourhood of zero in $M_{\mathbb{R}}$, \mathcal{P} looks locally near v_i like a fan Σ_i in $M_{\mathbb{R}}$. This fan defines a toric variety X_i , and X_1, \dots, X_m will be the irreducible components of \mathcal{X}_0 . We then glue together the components of $\{X_i\}$ using the combinatorics dictated by \mathcal{P} . Specifically, if v_i and v_j are joined by an edge $e \in \mathcal{P}$, then this edge defines rays in both Σ_i and Σ_j , and hence divisors D_i and D_j in X_i and X_j . It follows from condition (5) of Definition 2.4 that D_i and D_j are isomorphic: they are in fact defined by the same fan. This isomorphism is canonical, and we glue X_i and X_j along these divisors using this canonical isomorphism. Again, one can show that (5) of Definition 2.4 guarantees all such gluings are compatible, and one obtains a scheme \mathcal{X}_0 .

There are several points to make here. First, there is actually a whole moduli space of such gluings. We said above that there was a canonical isomorphism between D_i and D_j , but such an isomorphism can be twisted by an automorphism of D_i . Thus if one specifies, for each pair i, j an automorphism of D_i , and demands in addition some compatibility conditions, one obtains a new gluing which is not necessarily isomorphic to the original gluing. In fact, one can parametrize the set of all possible gluings by a Čech cohomology group of a sheaf on B .

The second point is that just knowing \mathcal{X}_0 gives nowhere near enough information to smooth \mathcal{X}_0 correctly. In particular, we have so far only used the fan structure of \mathcal{P} , and used no information about the maximal cells of \mathcal{P} . There may be different smoothings of \mathcal{X}_0 depending on this data: we saw this in Example 2.10, (2) and (3), where there can be many different smoothings of a cycle of rational curves, giving different singularities of the total space of the smoothing. In particular, just knowing \mathcal{X}_0 tells us nothing about the toric varieties Y_x which may appear as local models for a smoothing $\mathcal{X} \rightarrow S$. We rectify this by introducing *log structures*.

Roughly put, a log structure is some additional structure on \mathcal{X}_0 which reflects some essentially toric information about the embedding $\mathcal{X}_0 \subseteq \mathcal{X}$. This may be viewed as something akin to infinitesimal information about the smoothing.

Recall a *monoid* is a set with an associative product with a unit. We will only use commutative monoids here.

Definition 3.1. A log structure on a scheme (or analytic space) X is a (unital) homomorphism

$$\alpha_X : \mathcal{M}_X \rightarrow \mathcal{O}_X$$

of sheaves of (multiplicative) monoids inducing an isomorphism $\alpha_X^{-1}(\mathcal{O}_X^\times) \rightarrow \mathcal{O}_X^\times$. The triple $(X, \mathcal{M}_X, \alpha_X)$ is then called a *log space*. We often write the whole package as X^\dagger .

A morphism of log spaces $F : X^\dagger \rightarrow Y^\dagger$ consists of a morphism $\underline{F} : X \rightarrow Y$ of underlying spaces together with a homomorphism $F^\# : \underline{F}^{-1}(\mathcal{M}_Y) \rightarrow \mathcal{M}_X$ commuting with the structure homomorphisms:

$$\alpha_X \circ F^\# = \underline{F}^* \circ \alpha_Y.$$

The key examples:

Examples 3.2. (1) Let X be a scheme and $D \subseteq X$ a closed subset of codimension one. Denote by $j : X \setminus D \rightarrow X$ the inclusion. Then the inclusion

$$\alpha_X : \mathcal{M}_X = j_*(\mathcal{O}_{X \setminus D}^\times) \cap \mathcal{O}_X \rightarrow \mathcal{O}_X$$

of the sheaf of regular functions with zeroes contained in D is a log structure on X .

(2) A *prelog structure*, i.e. an arbitrary homomorphism of sheaves of monoids $\varphi : \mathcal{P} \rightarrow \mathcal{O}_X$, defines an associated log structure \mathcal{M}_X by

$$\mathcal{M}_X = (\mathcal{P} \oplus \mathcal{O}_X^\times) / \{(p, \varphi(p)^{-1}) \mid p \in \varphi^{-1}(\mathcal{O}_X^\times)\}$$

and $\alpha_X(p, h) = h \cdot \varphi(p)$.

(3) If $f : X \rightarrow Y$ is a morphism of schemes and $\alpha_Y : \mathcal{M}_Y \rightarrow \mathcal{O}_Y$ is a log structure on Y , then the prelog structure $f^{-1}(\mathcal{M}_Y) \rightarrow \mathcal{O}_X$ defines an associated log structure on X , the *pull-back log structure*.

(4) In (1) we can pull back the log structure on X to D using (3). Thus in particular, if $\mathcal{X} \rightarrow S$ is a toric degeneration, the inclusion $\mathcal{X}_0 \subseteq \mathcal{X}$ gives a log structure on \mathcal{X} and an induced log structure on \mathcal{X}_0 . Similarly the inclusion $0 \in S$ gives a log structure on S and an induced one on 0 . Here $\mathcal{M}_0 = \mathbb{C}^\times \oplus \mathbb{N}$, where \mathbb{N} is the (additive) monoid of natural (non-negative) numbers, and

$$\alpha_0(h, n) = \begin{cases} h & n = 0 \\ 0 & n \neq 0. \end{cases}$$

We then have log morphisms $\mathcal{X}^\dagger \rightarrow S^\dagger$ and $\mathcal{X}_0^\dagger \rightarrow 0^\dagger$.

(5) If $\sigma \subseteq M_{\mathbb{R}}$ is a cone, $\sigma^\vee \subseteq N_{\mathbb{R}}$ the dual cone, let $P = \sigma^\vee \cap N$: this is a monoid. The affine toric variety defined by σ can be written as $X = \text{Spec } \mathbb{C}[P]$. Here $\mathbb{C}[P]$ denotes the monoid ring of P , generated as a vector space over \mathbb{C} by symbols $\{z^p \mid p \in P\}$ with multiplication given by $z^p \cdot z^{p'} = z^{p+p'}$.

We then have a pre-log structure induced by the homomorphism of monoids

$$P \rightarrow \mathbb{C}[P]$$

given by $p \mapsto z^p$. There is then an associated log structure on X . If $p \in P$, then the monomial z^p defines a map $f : X \rightarrow \text{Spec } \mathbb{C}[\mathbb{N}]$ ($= \text{Spec } \mathbb{C}[t]$) which is a log morphism. The fibre $X_0 = \text{Spec } \mathbb{C}[P]/(z^p)$ is a subscheme of X , and there is an induced log structure on X_0 , and a map $X_0^\dagger \rightarrow 0^\dagger$ as in (4).

Condition (4) of Definition 1.1 in fact implies that locally, away from Z , \mathcal{X}^\dagger and \mathcal{X}_0^\dagger are of the above form.

Remark 3.3. It is sometimes useful to think about a log structure via the exact sequence

$$1 \rightarrow \mathcal{O}_X^\times \rightarrow \mathcal{M}_X \rightarrow \overline{\mathcal{M}}_X \rightarrow 0 \quad (1)$$

defining a sheaf of monoids $\overline{\mathcal{M}}_X$. For example, consider Example 3.2, (1), with $D = \{x_1x_2 = 0\} \subseteq X = \text{Spec } k[x_1, x_2]$, $D = D_1 \cup D_2$, with $D_i = \{x_i = 0\}$. If $i_j : D_j \rightarrow X$ are the inclusions, then $\overline{\mathcal{M}}_X = i_{1*}\mathbb{N} \oplus i_{2*}\mathbb{N}$, and an element $f \in \mathcal{M}_X$ is mapped to (n_1, n_2) , where n_j is the order of vanishing of f along D_j . Pulling back this log structure to D , one obtains a similar exact sequence with $\overline{\mathcal{M}}_D = \overline{\mathcal{M}}_X$.

Example 3.2, (5) is important. The beauty of log geometry is that we are able to treat such an \mathcal{X}_0^\dagger as if it were a non-singular variety. Essentially, we say a log scheme over 0^\dagger which is locally of the form given in (5) is *log smooth* over 0^\dagger . In particular, on a log smooth scheme, there is a sheaf of logarithmic differentials which is locally free. F. Kato has developed deformation theory for such log schemes.

The philosophy is then as follows. Given B, \mathcal{P} , we have constructed a space \mathcal{X}_0 . We first try to put a log structure on \mathcal{X}_0 such that there is a set $Z \subseteq \text{Sing}(\mathcal{X}_0)$ not contained in any toric stratum of \mathcal{X}_0 such that $\mathcal{X}_0^\dagger \setminus Z$ is log smooth. We then try to deform \mathcal{X}_0^\dagger in a family to get $\mathcal{X}^\dagger \rightarrow S^\dagger$, and do this in such a way that the underlying map of spaces $\mathcal{X} \rightarrow S$ is a toric degeneration.

This is the technical heart of the program, and we will only give some hints here of how this works.

The first point is that given B, \mathcal{P} , we constructed \mathcal{X}_0 by gluing together its irreducible components. However, it can also be constructed by describing an open cover and a gluing of these open sets. Specifically, if $\sigma \in \mathcal{P}$, we can view σ as a polytope in $M_\mathbb{R}$, and let $\tilde{\sigma}$ be the cone over σ in $M_\mathbb{R} \oplus \mathbb{R}$, i.e.

$$\tilde{\sigma} = \{(rm, r) \mid r \in \mathbb{R}_{\geq 0}, m \in \sigma\}.$$

Then $\tilde{\sigma}$ defines an affine toric variety Y_σ , and writing $\text{Hom}_\mathbb{Z}(M \oplus \mathbb{Z}, \mathbb{Z})$ as $N \oplus \mathbb{Z}$, $\rho = (0, 1) \in N \oplus \mathbb{Z}$ represents a monomial z^ρ on Y_σ . We let X_σ be defined by the equation $z^\rho = 0$ in Y_σ . We are simply reversing the procedure described in §2 to obtain B from a toric degeneration. It is then not difficult to show that $\{X_\sigma \mid \sigma \in \mathcal{P}\}$ form a natural open covering of \mathcal{X}_0 , and one can explicitly describe how they glue.

We have gained from this description a natural log structure on X_σ coming from the inclusion $X_\sigma \subseteq Y_\sigma$ as in Example 3.2, (4) or (5), and so we have an open covering of \mathcal{X}_0 by log schemes which are log smooth over 0^\dagger , $\{X_\sigma^\dagger \rightarrow 0^\dagger \mid \sigma \in \mathcal{P}\}$.

The problem is that unless $Z = \emptyset$, the log structures don't glue. However, it is possible to define a "sheaf of log structures on X_σ over 0^\dagger " consisting essentially of deformations of the given log structure. This is a rather technical but important point.

Given a log structure, in a certain sense, it is the extension class of $\overline{\mathcal{M}}_X$ by \mathcal{O}_X^\times in (1) which determines the log structure. In our case, the sheaves $\overline{\mathcal{M}}_{X_\sigma}$ do glue, so one can define a sheaf of monoids $\overline{\mathcal{M}}_{\mathcal{X}_0}$ globally on \mathcal{X}_0 . The "sheaf of log smooth structures" $LS(\mathcal{X}_0)$ can then be defined as an appropriate subsheaf of $\mathcal{E}xt^1(\overline{\mathcal{M}}_{\mathcal{X}_0}^{gp}, \mathcal{O}_{\mathcal{X}_0}^\times)$. Here the superscript *gp* refers to the Grothendieck group of the monoid.

Examples 3.4. (1) A simple example shows that one can have a non-trivial family of log structures even very locally: let $X \subseteq \mathbb{C}^4 = \text{Spec } \mathbb{C}[x, y, z, w]$ be given by the equations $xy = zw = 0$. Then there is a natural one-parameter family of log structures on X induced by the inclusions $X \subseteq Y_\lambda$, where Y_λ is the quadric given by the equation $xy - \lambda zw = 0$, $\lambda \in \mathbb{C}^\times$. This gives a family of log structures X_λ^\dagger , and there is no isomorphism $f: X_\lambda^\dagger \rightarrow X_{\lambda'}^\dagger$ of log schemes which is the identity on the underlying scheme X unless $\lambda = \lambda'$.

(2) If \mathcal{X}_0^\dagger has normal crossings, (i.e. all elements of \mathcal{P} are standard simplices) and if $D \in \text{Sing}(\mathcal{X}_0)$, there is a standard line bundle \mathcal{N}_D on D which can be defined as the sheaf of local infinitesimal deformations $\text{Ext}^1(\Omega_{\mathcal{X}_0}^1, \mathcal{O}_{\mathcal{X}_0})$. Then $LS(\mathcal{X}_0)$ turns out to be the \mathcal{O}_D^\times -torsor associated to \mathcal{N}_D , i.e. the sheaf of nowhere zero sections of \mathcal{N}_D . Thus there only exists a log smooth structure on \mathcal{X}_0 if $\mathcal{N}_D \cong \mathcal{O}_D$ (see [16]). In fact, this will only be the case if the minimal discriminant locus $\Delta \subseteq B$ is empty, and one can read off \mathcal{N}_D from information about the discriminant locus. This is the reason we must allow singularities in the log structure in the presence of singularities on B .

(3) The reader may wonder why we can't restrict to normal crossings outside of Z , where from (2) it appears the theory is relatively simple.

There are several reasons why we can't do this and don't want to do this. Indeed, the toric situation is the most natural one. First, one might argue you could try to further subdivide \mathcal{P} so it consists only of standard simplices. Even if Δ is empty, this cannot be done in dimension four or higher, as it is well-known that in these dimensions there exists simplices which cannot be subdivided into elementary ones. More seriously, one can't even always subdivide into simplices. In three dimensions, say, if one has a long strand in Δ , one finds the definition of a toric polyhedral decomposition requires that any one-dimensional cell intersecting this strand is constrained to lie in a given plane containing that strand and parallel to a certain line contained in that plane. This results in decompositions which involve polyhedra which necessarily aren't simplices, as depicted in the following picture:

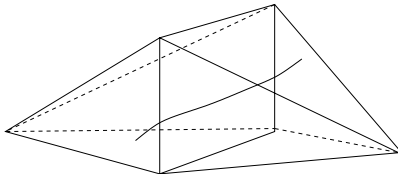

Finally, even if we do have a normal crossings example, the mirror construction given in the next section will almost certainly never result in a mirror family which is normal crossings. So the toric setting is imperative for this approach.

Thus, in general, we can obtain log smooth structures on dense open subsets $U \subseteq \mathcal{X}_0$, with $\mathcal{X}_0 \setminus U = Z$ the singular set. However, there are additional restrictions on the nature of the singularities of the log structure to ensure there is a local smoothing. For example, in the normal crossings case, we can only allow sections of $LS(\mathcal{X}_0)$ to have zeroes, but not poles, along the singular set Z ; i.e. the allowable log structures on \mathcal{X}_0 are determined by

sections of \mathcal{N}_D . Thus some additional positivity condition is required, and this is reflected in the holonomy of the affine structure about Δ .

This allows us to construct a moduli space of allowable log structures on \mathcal{X}_0 . Combining this with the fact that \mathcal{X}_0 itself might have locally trivial deformations coming from a family of possible gluings of the irreducible components, we obtain a whole moduli space of such log schemes.

It remains an open question being actively researched to determine when such \mathcal{X}_0^\dagger is smoothable. This will be the final step of the program. We restrict our comments here to the statement that in dimension ≤ 2 , suitably positive \mathcal{X}_0^\dagger are always smoothable, but in dimension ≥ 3 , one can construct non-smoothable examples (analogous to examples of non-smoothable three-dimensional canonical singularities). However, we expect smoothability to be implied by certain conditions on B .

4. The intersection complex, the discrete Legendre transform, and mirror symmetry

Now let $\mathcal{X} \rightarrow S$ be a toric degeneration, $\dim \mathcal{X}_0 = n$. Suppose in addition it is polarised by a relatively ample line bundle, i.e. a line bundle \mathcal{L} on \mathcal{X} which restricts to an ample line bundle on \mathcal{X}_t for each $t \in S$ (including $t = 0$). Then one can construct another integral affine manifold with singularities \check{B} with a polyhedral decomposition $\check{\mathcal{P}}$ from this data. Just as B, \mathcal{P} of §3 was the dual intersection complex, $\check{B}, \check{\mathcal{P}}$ is the intersection complex, but the polarization is necessary to define the affine structure.

There are two ways to think about \check{B} . First, the more direct way is as follows. Again assume every component of \mathcal{X}_0 is normal. For each component X_i of \mathcal{X}_0 , let σ_i be the Newton polytope of $\mathcal{L}|_{X_i}$ in $N_{\mathbb{R}}$. This is a lattice polytope which is well-defined up to affine linear transformations. The cells of σ_i are in a one-to-one inclusion preserving correspondence with the toric strata of X_i , and we can then identify cells of σ_i and σ_j if the corresponding toric strata of X_i and X_j are identified in \mathcal{X}_0 . Making these identifications gives \check{B} . To get the singular affine structure on \check{B} , we need to specify a fan structure at each vertex of \check{B} . But a vertex of \check{B} corresponds to $\{x\} \in \text{Strata}(\mathcal{X}_0)$ with an associated polyhedron $\sigma_x \subseteq M_{\mathbb{R}}$. We define the normal fan $\check{\Sigma}_x$ of σ_x to be the fan whose cones are in one-to-one inclusion reversing correspondence with the cells τ of σ_x , with the cone corresponding to τ given by

$$\{f \in N_{\mathbb{R}} \mid f|_{\tau} \text{ is constant and } \langle f, z \rangle \geq \langle f, y \rangle \text{ for all } z \in \sigma_x, y \in \tau\}$$

We then take the fan $\check{\Sigma}_x$ to determine the fan structure at the corresponding vertex of \check{B} .

Proposition 4.1. *\check{B} is an integral affine manifold with singularities, and $\check{\mathcal{P}}$ is a toric polyhedral decomposition on \check{B} . If $\check{\Delta} \subseteq \check{B}$ is the minimal discriminant locus of the affine structure, then there is a homeomorphism $\alpha : B \rightarrow \check{B}$ with $\alpha(\Delta) = \check{\Delta}$. Furthermore, the affine structures on B and \check{B} are dual in the sense that the holonomy representations of the flat connections on \mathcal{T}_B and $\mathcal{T}_{\check{B}}$ induced by the respective affine structures are naturally dual.*

\check{B} can be described more intrinsically in terms of B and \mathcal{P} using the discrete Legendre transform.

Definition 4.2. If B is an affine manifold with singularities, let $\text{Aff}(B, \mathbb{R})$ denote the sheaf of functions on B with values in \mathbb{R} which are affine linear when restricted to B_0 . Let \mathcal{P} be a polyhedral decomposition of B . If $U \subseteq B$ is an open set, then a *piecewise linear* function on U is a continuous function $f : U \rightarrow \mathbb{R}$ which is affine linear on $U \cap \text{Int}(\sigma)$ for each maximal $\sigma \in \mathcal{P}$, and which satisfies the following property: for any $y \in U$, $y \in \text{Int}(\sigma)$ for some $\sigma \in \mathcal{P}$, there exists a neighbourhood V of y and a $g \in \Gamma(V, \text{Aff}(B, \mathbb{R}))$ such that $f - g$ is zero on $V \cap \text{Int}(\sigma)$.

Definition 4.3. A *multi-valued piecewise linear function* on B with respect to \mathcal{P} is a collection of piecewise linear functions (U_i, φ_i) for $\{U_i\}$ an open cover of B , such that $\varphi_i - \varphi_j \in \Gamma(U_i \cap U_j, \text{Aff}(B, \mathbb{R}))$ for all i, j . We say a multivalued piecewise linear function φ is *strictly convex* if at every vertex v of \mathcal{P} , some representative φ_i is strictly convex in a neighbourhood of v (in the usual sense of a strictly convex piecewise linear function on a fan).

Let φ be a strictly convex multi-valued piecewise linear function on B with only integral slopes. We will construct a new integral affine manifold with singularities \check{B} with discriminant locus $\check{\Delta}$. As manifolds, $B = \check{B}$ and $\Delta = \check{\Delta}$, but the affine structures are dual. In addition, we obtain a toric polyhedral decomposition $\check{\mathcal{P}}$ and a strictly convex multi-valued piecewise linear function $\check{\varphi}$ with integral slope on \check{B} . We will say $(\check{B}, \check{\mathcal{P}}, \check{\varphi})$ is the *discrete Legendre transform* of $(B, \mathcal{P}, \varphi)$.

First we define $\check{\mathcal{P}}$. For any $\sigma \in \mathcal{P}$, define $\check{\sigma}$ to be the union of all simplices in $\text{Bar}(\mathcal{P})$ intersecting σ but disjoint from any proper subcell of σ . Put

$$\check{\mathcal{P}} = \{\check{\sigma} \mid \sigma \in \mathcal{P}\}.$$

This is the usual dual cell complex to σ , with $\dim \check{\sigma} = n - \dim \sigma$. Of course, $\check{\sigma}$ is not a polyhedron with respect to the affine structure on B , and we will build a new affine structure on B using the method of §2.

For any vertex $v \in \mathcal{P}$, we obtain a fan Σ_v living in $\mathcal{T}_{B,v}$, and locally, φ defines a piecewise linear function φ_v on the fan Σ_v up to a choice of a linear function. This function is strictly convex by assumption, and we can consider the corresponding Newton polytope, i.e. set

$$\check{v}' = \{x \in \mathcal{T}_{B,v}^* \mid \langle x, y \rangle \geq -\varphi_v(y) \quad \forall y \in \mathcal{T}_{B,v}\}.$$

Note that because φ_v is strictly convex there is a one-to-one inclusion reversing correspondence between the cells of \check{v}' and cones in Σ_v ; if $\tau \in \Sigma_v$, the corresponding cell $\check{\tau} \subseteq \check{v}'$ is

$$\check{\tau} = \{x \in \check{v}' \mid \langle x, y \rangle = -\varphi_v(y) \quad \forall y \in \tau\}.$$

In addition, \check{v}' is an integral polytope because φ_v has integral slopes.

Each \check{v}' can then be identified in a canonical way with $\check{v} \in \check{\mathcal{P}}$. This can be done in a piecewise linear way on each simplex of the first barycentric subdivision of \check{v}' . This gives

an identification of \check{v} with a lattice polytope in $N_{\mathbb{R}}$, giving the first step of the construction of the dual affine structure on B .

To finish specifying an integral affine structure with singularities on $\check{B} = B$, we just need to specify a fan structure at each vertex $\check{\sigma}$ of $\check{\mathcal{P}}$ (for σ a maximal cell of \mathcal{P}). We take the fan structure at $\check{\sigma}$ to be given by the normal fan $\check{\Sigma}_{\sigma}$ of σ , just as before.

Finally, we wish to define $\check{\varphi}$, the Legendre transform of φ . We do this by defining $\check{\varphi}$ in a neighbourhood of each vertex $\check{\sigma}$ of $\check{\mathcal{P}}$, where $\sigma \in \mathcal{P}$ is a maximal cell. This is equivalent to giving a piecewise linear function $\check{\varphi}_{\check{\sigma}}$ on the normal fan $\check{\Sigma}_{\sigma}$ of σ , viewing σ as a polytope in $M_{\mathbb{R}}$. Since we want the operation of discrete Legendre transform to be a duality, σ must be obtained as the Newton polytope coming from the function $\check{\varphi}_{\check{\sigma}}$ on $\check{\Sigma}_{\sigma}$, and thus we are forced to define $\check{\varphi}_{\check{\sigma}}$ by

$$\check{\varphi}_{\check{\sigma}}(y) = -\inf\{\langle y, x \rangle \mid x \in \sigma\}$$

for $y \in N_{\mathbb{R}}$. This is a piecewise linear function on the fan $\check{\Sigma}_{\sigma}$, and it is a standard easy fact that it is strictly convex, with the Newton polyhedron of $\check{\varphi}_{\check{\sigma}}$ being σ . If σ is shifted in $M_{\mathbb{R}}$ by a translation, $\check{\varphi}_{\check{\sigma}}$ is changed by a linear function, so it is well-defined modulo linear functions.

Thus given the triple $(B, \mathcal{P}, \varphi)$, we obtain $(\check{B}, \check{\mathcal{P}}, \check{\varphi})$.

Now the point is that given a toric degeneration $\mathcal{X} \rightarrow S$, polarized by \mathcal{L} , we actually obtain a strictly convex multi-valued piecewise linear function on B : in a neighbourhood of each vertex v_i of \mathcal{P} corresponding to the irreducible component X_i of \mathcal{X}_0 , the line bundle $\mathcal{L}|_{X_i}$ yields a piecewise linear function, up to a linear function, on the corresponding fan Σ_i . This defines a piecewise linear function φ_i in a neighbourhood of v_i on B . One can check these define a multi-valued piecewise linear function on B , and it is strictly convex because $\mathcal{L}|_{X_i}$ is ample for each i . Thus we obtain a triple $(B, \mathcal{P}, \varphi)$, which we call the *degeneration data* associated to $\mathcal{X} \rightarrow S$, \mathcal{L} .

It is easy to see that the first construction of $\check{B}, \check{\mathcal{P}}$ given here as the intersection complex coincides with the data from $(\check{B}, \check{\mathcal{P}}, \check{\varphi})$, the discrete Legendre transform of $(B, \mathcal{P}, \varphi)$.

We now come to the fundamental idea of the paper: *mirror symmetry can be understood as a duality between toric degenerations with dual degeneration data*. For example, if $f : \mathcal{X} \rightarrow S$ and $\check{f} : \check{\mathcal{X}} \rightarrow S$ are polarized toric degenerations such that their degeneration data $(B, \mathcal{P}, \varphi)$ and $(\check{B}, \check{\mathcal{P}}, \check{\varphi})$ are related by the discrete Legendre transform, then f and \check{f} should be viewed as mirror degenerations. One should also consider the singular fibres by themselves: the log schemes \mathcal{X}_0^{\dagger} and $\check{\mathcal{X}}_0^{\dagger}$ along with polarisations carry enough data by themselves to define $(B, \mathcal{P}, \varphi)$ and $(\check{B}, \check{\mathcal{P}}, \check{\varphi})$. We can then say \mathcal{X}_0^{\dagger} and $\check{\mathcal{X}}_0^{\dagger}$ are a mirror pair of log schemes if again the degeneration data are related by the discrete Legendre transform.

Strictly speaking, mirror symmetry should be about families. One can make more precise statements, defining suitable moduli spaces of log schemes and log Kähler moduli. Under suitable hypotheses, roughly implying the degeneration is a large complex structure limit rather than just a maximally unipotent degeneration, one can define a natural mirror map identifying these two different moduli spaces for a mirror pair. Furthermore, in this

case, we expect that we can deduce results about the smoothings \mathcal{X}_t and $\check{\mathcal{X}}_t$ for $t \neq 0$, and in particular demonstrate that $h^{1,1}(\mathcal{X}_t) = h^{1,n-1}(\check{\mathcal{X}}_t)$ and $h^{1,n-1}(\mathcal{X}_t) = h^{1,1}(\check{\mathcal{X}}_t)$. It is likely, given appropriate assumptions, that this will follow from standard techniques of log geometry. Of course, it cannot hold in general because \mathcal{X}_t need not be smooth, but only have canonical singularities, in which case it is not clear what the correct equalities should be.

This conception of mirror symmetry fits with the Batyrev-Borisov mirror symmetry construction [3], and generalises that construction. While it also applies to degenerations of complex tori, where traditional forms of mirror symmetry for complex tori are reproduced, it is not clear how much broader this construction is. However, we expect it should be significantly broader, and it certainly puts many different forms of mirror symmetry on an equal footing.

Philosophically, once the details of the basic construction are complete, one can hope that one can study mirror symmetry for non-singular Calabi-Yau manifolds by studying mirror symmetry for log schemes. Many objects of interest should have analogous log versions. For example, if one is interested in computing Gromov-Witten invariants, one can try to define log Gromov-Witten invariants, which can be computed on the singular fibre \mathcal{X}_0^\dagger . If defined appropriately, these invariants will remain stable under smoothing, and so one reduces the calculation of Gromov-Witten invariants to the singular case, which may be easier. In particular, one should be able to relate such calculations to questions of combinatorics of graphs on B , much as in [18] and [5]. This approach has been started by the second author in [28], and though technical problems remain, we believe log Gromov-Witten invariants can be defined. Previous general work in this direction is due to Tian; Li and Ruan [21]; Ionel and Parker [15]; Gathmann [6] and Li [22],[23], who covers cases relative a smooth divisor and of normal crossing varieties with smooth singular locus. Nevertheless, this approach remains a major undertaking.

Example 4.4. Let $f : \mathcal{X} \rightarrow S$ be a degeneration of elliptic curves as in Example 2.10, (3), with $B = \mathbb{R}/m\mathbb{Z}$, decomposed into line segments of lengths m_1, \dots, m_p with $\sum m_i = m$, so that \mathcal{X}_0 has p components. Choose a polarization on \mathcal{X} of degree n , which is degree n_1, \dots, n_p on the p components of \mathcal{X}_0 respectively ($n_i \geq 1$, $\sum n_i = n$). Then \check{B} is a union of line segments of lengths n_1, \dots, n_p , so $\check{B} = \mathbb{R}/n\mathbb{Z}$. This yields a new degeneration $\check{f} : \check{\mathcal{X}} \rightarrow S$, with a polarization which is degree m_1, \dots, m_p on the irreducible components of $\check{\mathcal{X}}_0$.

Of course, the precise geometry of the singular fibres and their polarizations are dependent on the initial choice of polyhedral decomposition \mathcal{P} and φ , but if one deletes the singular fibres, these differences disappear. Letting $S^* = S \setminus \{0\}$, $f : \mathcal{X}^* = f^{-1}(S^*) \rightarrow S^*$, and $\check{f} : \check{\mathcal{X}}^* \rightarrow S^*$ give two families of polarized elliptic curves, one with monodromy in H^1 being $\begin{pmatrix} 1 & m \\ 0 & 1 \end{pmatrix}$ in a suitable basis of cohomology, with the polarization of degree n , and the other with the roles of m and n reversed. This is the manifestation of mirror symmetry here.

Remark 4.5. This construction should give mirror pairs for toric degenerations, at least with certain additional conditions, but there remains the question of how general a mirror symmetry construction this is. More generally, the general mirror symmetry conjecture suggests there should be mirror partners associated to any large complex structure limit (see [24]). Now in general a toric degeneration is a maximally unipotent degeneration, but does not necessarily satisfy the stronger condition of being a large complex structure limit. We do not expect that any maximally unipotent degeneration is birationally equivalent to a toric degeneration. However, there is some tenuous evidence which leads one to speculate that any large complex structure degeneration is in fact birationally equivalent to a toric degeneration. If this is the case, our proposed construction will yield a general mirror symmetry construction.

5. Connections with the Strominger-Yau-Zaslow conjecture

This approach to mirror symmetry is closely related to the Strominger-Yau-Zaslow approach, and we believe that it should be viewed as an algebro-geometrisation of SYZ, a discretization, so to speak.

Recall briefly that in Hitchin's approach to SYZ [13] (see also [19]), one considers an affine manifold B whose transition functions are contained in $\text{Aff}_{\mathbb{R}}(M)$ (rather than $\text{Aff}(M)$ or $\text{Aff}(M_{\mathbb{R}})$). Then there is a well-defined family of sublattices Λ of \mathcal{T}_B generated by $\partial/\partial y_1, \dots, \partial/\partial y_n$ if y_1, \dots, y_n are local affine coordinates. Because of the restriction on transition functions, this basis is well-defined up to elements of $GL_n(\mathbb{Z})$; hence $\Lambda \subseteq \mathcal{T}_B$ is well-defined. We can set $X(B) = \mathcal{T}_B/\Lambda$. This comes along with a complex structure: locally one can define holomorphic coordinate functions z_i on $X(B)$ over a point in B with coordinates (y_1, \dots, y_n) ,

$$z_i \left(\sum_j x_j \frac{\partial}{\partial y_j} \right) = e^{2\pi\sqrt{-1}(x_j + \sqrt{-1}y_j)}.$$

If we also have a strictly convex differentiable function φ on B (i.e. $(\partial^2\varphi/\partial y_i\partial y_j)$ is positive definite for affine coordinates y_1, \dots, y_n), then if $\pi : X(B) \rightarrow B$ is the projection, $\varphi \circ \pi$ is the Kähler potential of a Kähler metric on $X(B)$ (Ricci flat if φ satisfies the real Monge-Ampère equation $\det(\partial^2\varphi/\partial y_i\partial y_j) = \text{constant}$).

To obtain the mirror of $X(B)$, one defines a new affine structure on B with local coordinates given by $\check{y}_i = \partial\varphi/\partial y_i$. One also obtains a function

$$\check{\varphi}(\check{y}_1, \dots, \check{y}_n) = \sum_{i=1}^n y_i \check{y}_i - \varphi(y_1, \dots, y_n),$$

the Legendre transform of φ .

The data $\check{B}, \check{\varphi}$ defines a new Kähler manifold $X(\check{B})$ which is SYZ-dual to $X(B)$.

One of the difficulties with this approach is that this is only an approximation, and it only gives mirror symmetry precisely in the complex torus case. In other cases, one expects singular fibres which destroy the ability to have a pleasant complex structure on

$X(B)$ (and in fact if B has singularities, we don't know how to define $X(B)$). However, one can show these bundles can be good approximations to the genuine complex structures.

Let us move towards a more precise statement here. First, we need to underline the importance of *integral* affine structures for the study of large complex structure limits. This was first observed by Kontsevich and Soibelman [18]. For convenience, let us first introduce a few additional concepts of affine manifolds and torus bundles over them.

Let $\pi : \tilde{B} \rightarrow B$ be the universal covering of an (integral) affine manifold B , inducing an (integral) affine structure on \tilde{B} . Then there is an (integral) affine immersion $d : \tilde{B} \rightarrow M_{\mathbb{R}}$, called the *developing map*, and any two such maps differ only by an (integral) affine transformation. This map is obtained in a standard way by patching together (integral) affine coordinate charts on B . We can then obtain the *holonomy representation* as follows. The fundamental group $\pi_1(B)$ acts on \tilde{B} by deck transformations; for $\gamma \in \pi_1(B)$, let $T_\gamma : \tilde{B} \rightarrow \tilde{B}$ be the corresponding deck transformation with $T_{\gamma_1} \circ T_{\gamma_2} = T_{\gamma_2 \gamma_1}$. Then by the uniqueness of the developing map, there exists a $\rho(\gamma) \in \text{Aff}(M_{\mathbb{R}})$ such that $\rho(\gamma) \circ d \circ T_\gamma = d$. The map $\rho : \pi_1(B) \rightarrow \text{Aff}(M_{\mathbb{R}})$ is called the *holonomy representation*. If the affine structure is integral, then $\text{im } \rho \subseteq \text{Aff}(M)$.

Now suppose B is equipped with an integral affine structure, with developing map $d : \tilde{B} \rightarrow M_{\mathbb{R}}$ and holonomy representation $\rho : \pi_1(B) \rightarrow \text{Aff}(M)$. Suppose $d' : \tilde{B} \rightarrow M_{\mathbb{R}}$ is another map, not necessarily an immersion, such that there is a representation $\rho' : \pi_1(B) \rightarrow \text{Aff}(M_{\mathbb{R}})$ satisfying $\rho'(\gamma) \circ d' \circ T_\gamma = d'$. Assume that ρ and ρ' have the same linear parts, i.e. agree if composed with the natural projection $\text{Aff}(M_{\mathbb{R}}) \rightarrow GL(M_{\mathbb{R}})$. Assume furthermore that for $r > R$, $rd + d' : \tilde{B} \rightarrow M_{\mathbb{R}}$ is an immersion. Then in this case we can form a new affine manifold

$$\bar{B} = B \times (R, \infty)$$

defined by a developing map

$$\bar{d} : \tilde{B} \times (R, \infty) \rightarrow M_{\mathbb{R}} \times \mathbb{R}$$

given by

$$\bar{d}(b, r) = (rd(b) + d'(b), r).$$

One can check that this defines an affine structure on \bar{B} with transition maps (or holonomy representation) contained in

$$(M_{\mathbb{R}} \oplus \mathbb{R}) \rtimes GL(M \oplus \mathbb{Z}),$$

i.e. has integral linear part. If the affine structure coming from d had not been integral to begin with, we would not have had the integrality of the linear part for \bar{B} , and thus been unable to form the complex manifold $X(\bar{B})$.

$X(\bar{B})$ is a complex manifold of dimension $n + 1$. The projection $\bar{B} \rightarrow (R, \infty)$ induces a map of complex manifolds $X(\bar{B}) \rightarrow S^* = X((R, \infty))$, the latter being a punctured disk of radius $e^{-2\pi R}$. This is a family of n -dimensional complex manifolds, with, in general, non-trivial monodromy.

There is one more refinement of this. Given an open covering $\{U_i\}$ of B and $\alpha = (\alpha_{ij})$ a Čech 1-cocycle of flat sections of \mathcal{T}_B/Λ , we can glue $X(U_i)$ and $X(U_j)$ by fibrewise

translating by α_{ij} before gluing. This translation is holomorphic, and so the glued manifold is still a complex manifold, which can be viewed as a twisted form of $X(B)$. We write this as $X(B, \alpha)$.

Next we define what we mean by a small deformation.

For an affine manifold B with the linear part of the holonomy being integral, we would like to define the notion of a small deformation of the complex manifold $X(B, \alpha)$. First, we need to answer the question of how we should think of a deformation of this manifold. One begins with a fixed covering $\{U_i\}$ of B along with affine coordinate charts $\psi_i : U_i \rightarrow M_{\mathbb{R}}$ which are open immersions. Thus there is a natural identification of $X(U_i)$ with an open subset of $X(M_{\mathbb{R}}) \cong M_{\mathbb{R}} \otimes \mathbb{C}^{\times}$. Furthermore $X(B, \alpha)$ is obtained by gluing together the sets $X(U_i)$ and $X(U_j)$ (for each i and j) along $X(U_i \cap U_j)$ using a biholomorphic map $\varphi_{ij} : X(U_i \cap U_j) \rightarrow X(U_i \cap U_j)$. (These maps depend on α ; if $\alpha = 0$ they are the identity.)

To deform $X(B, \alpha)$, we should simply perturb these maps. To measure the size of this deformation, we measure the size of the perturbation. First, to measure distance between two points x, y in $X(M_{\mathbb{R}}) = M_{\mathbb{R}} + iM_{\mathbb{R}}/M$, take

$$d(x, y) = \inf\{\|\tilde{x} - \tilde{y}\|, \tilde{x}, \tilde{y} \text{ are lifts of } x, y \text{ to } M_{\mathbb{R}} + iM_{\mathbb{R}}\}.$$

Here $\|\cdot\|$ denotes the norm with respect to some fixed inner product on $M_{\mathbb{R}} \otimes \mathbb{C}$.

Formally, we say a complex manifold X is a *deformation of $X(B, \alpha)$ of size C* if X can be covered by open sets X_i along with isomorphisms $\varphi_i : X(U_i) \rightarrow X_i$ such that

- For any point $x \in \varphi_i^{-1}(X_i \cap X_j)$, there is a point $y \in X(U_i \cap U_j)$ such that $d(x, y) < C$, and conversely for any $y \in X(U_i \cap U_j)$, there exists an $x \in \varphi_i^{-1}(X_i \cap X_j)$ such that $d(x, y) < C$. (In other words, the gluing sets have only changed by distance at most C).
- For any point $x_i \in \varphi_i^{-1}(X_i \cap X_j)$ and $x_j \in X(U_j)$ with $\varphi_j(x_j) = \varphi_i(x_i)$, there exists a point $y \in X(U_i \cap U_j)$ with $d(x_i, y) < C$ and $d(x_j, \varphi_{ij}(y)) < C$.

One can then show the following.

Theorem 5.1. *Let $f : \mathcal{X} \rightarrow S$ be a toric degeneration, B the corresponding integral affine manifold with singularities. Then there exists*

- an open set $U \subseteq B$ such that $B \setminus U$ retracts onto the singular set Δ .
- A map $d' : \tilde{U} \rightarrow M_{\mathbb{R}}$ as above defining an affine structure on $\bar{U} = U \times (R, \infty)$.
- A Čech 1-cocycle α of flat sections of $\mathcal{T}_{\bar{U}}$, hence giving a map

$$g : X(\bar{U}, \alpha) \rightarrow X((R, \infty)) = \{t \in \mathbb{C} \mid 0 < |t| < e^{-2\pi R}\}.$$

- An identification of $X((R, \infty))$ with a punctured open neighbourhood of $0 \in S$.
- An open set $\mathcal{U} \subseteq \mathcal{X}$.
- Constants C_1 and C_2

such that for t sufficiently small, $f^{-1}(t) \cap \mathcal{U}$ is a deformation of $g^{-1}(t)$ of size $C_1|t|^{C_2}$. Here $g^{-1}(t)$ is itself of the form $X(B, \alpha')$ for some affine structure on B and Čech 1-cocycle α' , so it makes sense to talk about small deformations of $g^{-1}(t)$.

Thus, given an integral affine manifold with singularities B , if we can find a toric polyhedral decomposition \mathcal{P} of B , we can construct \mathcal{X}_0 , and hopefully a smoothing under nice circumstances. Then \mathcal{X}_t is a topological compactification of $X(U)$, and we also have a good approximation to the complex structure on an open subset of \mathcal{X}_t . Ideally, of course, we would like to describe \mathcal{X}_t explicitly as a topological compactification of $X(U)$. However, this is not possible in general as there may be a number of different compactifications. In special cases, it is possible to prove stronger results, but we do not give details here.

If $\mathcal{X} \rightarrow S$ is a polarized toric degeneration, with degeneration data $(B, \mathcal{P}, \varphi)$, we obtain $(\check{B}, \check{\mathcal{P}}, \check{\varphi})$ via the discrete Legendre transform, and if we have a corresponding polarized toric degeneration $\check{\mathcal{X}} \rightarrow S$, then $\check{\mathcal{X}}_t$ is a compactification of some $X(\check{B}_0)$, which is the dual torus bundle to $X(B_0) \rightarrow B_0$ by Proposition 4.1. Hence we recover at least a topological form of SYZ, along with additional information about complex structures. In addition, we see mirror symmetry as a duality between affine manifolds via the discrete Legendre transform, clearly related to the continuous Legendre transform appearing in SYZ.

Finally, let us underline the context of the error estimate in terms of the ideas of [10]. If $t \in S^*$ with $r = -\frac{\log|t|}{2\pi} \in (R, \infty)$, then $g^{-1}(t) \cong X(B, \alpha')$ where B has the affine structure given by $rd + d'$ and α' is some choice of twisting. One can alternatively rescale the affine structure by multiplying by $\epsilon = 1/r$, giving a developing map $d + \epsilon d'$, which one should think of as a small perturbation of d . Then $X(B, \alpha')$ can be viewed as a twist of $\mathcal{T}_B/\epsilon\Lambda$, where $\Lambda \subseteq \mathcal{T}_B$ is the lattice of integral vector fields coming from the affine structure $d + \epsilon d'$. Thus we see as $t \rightarrow 0$, $\epsilon \rightarrow 0$ and essentially the fibres are shrinking, with radius ϵ . The size of the deformation is then $O(e^{-C/\epsilon})$, i.e. decays exponentially in terms of the fibre radius. This is a very similar picture to that of [10]. In fact, if one has a potential function φ on $U \subseteq B_0$ satisfying the Monge-Ampère equation, then one can obtain an almost Ricci-flat metric on $f^{-1}(t) \cap \mathcal{U}$ for t sufficiently small. As Ilia Zharkov has also advocated [30], this is a first step towards proving a limiting form of the SYZ conjecture (see [7]). (In fact [12] contains a proof of the above theorem in the toric hypersurface case).

References

- [1] Alexeev, V., “Complete moduli in the presence of semiabelian group action,” to appear in *Journal of Alg. Geom.*
- [2] Alexeev, V., and Nakamura, I., “On Mumford’s construction of degenerating abelian varieties,” *Tohoku Math. J. (2)* **51** (1999), 399–420.
- [3] Batyrev, V., Borisov, L., “On Calabi-Yau complete intersections in toric varieties,” *Higher-dimensional complex varieties (Trento, 1994)*, 39–65, de Gruyter, Berlin, 1996.
- [4] Faltings, G., and Chai, C.-L., *Degeneration of Abelian Varieties*, with an appendix by David Mumford, *Ergebnisse der Mathematik und ihrer Grenzgebiete (3)*, 22, Springer-Verlag, Berlin, 1990.
- [5] Fukaya, K., “Asymptotic Analysis, Multivalued Morse Theory, and Mirror Symmetry,” preprint, 2002.

- [6] Gathmann, A., “Relative Gromov-Witten Invariants and the Mirror Formula,” preprint, 2000, math.AG/0009190.
- [7] Gross, M., “Examples of special Lagrangian fibrations,” in *Symplectic Geometry and Mirror Symmetry, Proceedings of the 4th KIAS Annual International Conference*, Edited by K. Fukaya, Y.G. Oh, K. Ono and G. Tian, World Scientific, 2001, 81–109.
- [8] Gross, M., Huybrechts, D., Joyce, D., *Calabi-Yau Manifolds and Related Geometries*, Springer-Verlag, 2003.
- [9] Gross, M., Siebert, B., “Affine Manifolds and Mirror Symmetry,” math. AG/0301222.
- [10] Gross, M, Wilson, P.M.H., “Large Complex Structure Limits of K3 Surfaces,” *J. Diff. Geom.*, **55**, (2000) 475–546.
- [11] Haase, C., and Zharkov, I., “Integral affine structures on spheres and torus fibrations of Calabi-Yau toric hypersurfaces I,” math.AG/0205321.
- [12] Haase, C., and Zharkov, I., “Integral affine structures on spheres and torus fibrations of Calabi-Yau toric hypersurfaces II,” math.AG/0301222.
- [13] Hitchin, N., “The Moduli Space of Special Lagrangian Submanifolds,” *Ann. Scuola Norm. Sup. Pisa Cl. Sci. (4)*, **25** (1997), 503–515.
- [14] Hu, S., “Semi-Stable Degeneration of Toric Varieties and Their Hypersurfaces,” math.AG/0110091.
- [15] Ionel, E., and Parker, T., “Gromov-Witten invariants of symplectic sums,” *Math. Res. Lett.* **5** (1998), 563–576.
- [16] Kawamata, Y., and Namikawa, Y., “Logarithmic deformations of normal crossing varieties and smoothing of degenerate Calabi-Yau varieties,” *Invent. Math.* **118** (1994), 395–409.
- [17] Kontsevich, M., *personal communication*, December 2000.
- [18] Kontsevich, M., and Soibelman, Y., “Homological Mirror Symmetry and Torus Fibrations,” in *Symplectic geometry and mirror symmetry (Seoul, 2000)*, 203–263, World Sci. Publishing, River Edge, NJ, 2001.
- [19] Leung, N.C., “Mirror Symmetry without Corrections,” math.DG/0009235.
- [20] Leung, N.C., Vafa, C., “Branes and Toric Geometry,” *Adv. Theor. Math. Phys.*, **2** (1998), 91–118.
- [21] Li, A.-M. and Ruan, Y.-B., “Symplectic surgery and Gromov-Witten invariants of Calabi-Yau 3-folds,” *Invent. Math.* **145** (2001), 151–218.
- [22] Li, J., “Stable Morphisms to Singular Schemes and Relative Stable Morphisms,” *J. Diff. Geom.*, **57**, (2001) 509–578.
- [23] Li, J., “A Degeneration Formula of GW-invariants,” *J. Diff. Geom.*, **60**, (2002) 199–293.
- [24] Morrison, D., “Compactifications of moduli spaces inspired by mirror symmetry,” in *Journées de Géométrie Algébrique d’Orsay (Orsay, 1992)*, Astérisque No. 218 (1993), 243–271.
- [25] Mumford, D., “An analytic construction of degenerating abelian varieties over complete rings,” *Compositio Math.* **24** (1972), 239–272.
- [26] Schröer, S., and Siebert, B., “Irreducible Degenerations of Primary Kodaira Surfaces,” in *Complex geometry (Göttingen, 2000)*, 193–222, Springer, 2002.
- [27] Schröer, S., and Siebert, B., “Toroidal Crossings and Logarithmic Structures,” preprint, math.AG/0211088.
- [28] Siebert, B., “Log Gromov-Witten Invariants,” unfinished manuscript, March 2001.

GROSS, SIEBERT

- [29] Zharkov, I., “Torus fibrations of Calabi-Yau hypersurfaces in toric varieties” *Duke Math. J.* **101** (2000), 237–257.
- [30] Zharkov, I., personal communication, 2002.

MATHEMATICS INSTITUTE, UNIVERSITY OF WARWICK, COVENTRY CV4 7AL, UNITED KINGDOM

DEPARTMENT OF MATHEMATICS, UCSD, LA JOLLA, CA 92093-0112, UNITED STATES
E-mail address: `mgross@maths.warwick.ac.uk`

MATHEMATISCHES INSTITUT, ALBERT-LUDWIGS-UNIVERSITÄT FREIBURG, ECKERSTRASSE 1, D-79104
FREIBURG, GERMANY
E-mail address: `bernd.siebert@math.uni-freiburg.de`